

AMENDMENT ACKNOWLEDGMENT

AMENDMENT NO. 2
Bid No: 4896MECH, 4896ELEC and
4896GEN Opening Date: 1/8/2021

Dated: 12/24/20

NOTICE

It is the sole responsibility of the sellers to ensure that it has received any and all Amendments and the Procurement Commissioner may in his/her sole discretion reject any bid for which all Amendments have not been executed and returned.

PROPOSAL FOR

Project No.: 71-21-4896-01

Description: Philadelphia Zoo Animal Hospital AHU-1 Replacement

IS AMENDED AS FOLLOWS:

1. Amendments will be posted in PRA Contracts to all known to have been added to the Bid holder's list or Qualified Sellers after the questionnaire due date. Each Seller shall ascertain prior to submitting Quote that Seller has received all Amendments issued, and shall acknowledge their receipt in their Quote on PRA Contracts.

2. Philadelphia Zoo Animal Hospital AHU-1 Replacement

Specification Sections:

Remove the following Specification Sections in their entirety:

1. "71-21-4896-01 Section 230993 Sequence of Operations for HVAC Controls"

Replace the exact same drawing with the following updated under Amendment #1 12/24/20:

1. "71-21-4896-01 Section 230993 Sequence of Operations for HVAC Controls"

3. Philadelphia Zoo Animal Hospital AHU-1 Replacement

Contract Drawings:

Remove the following Contract Drawings in their entirety:

1. M1.0 "Mechanical Roof New Work AHU-1"
2. M2.0 "Mechanical Roof Work Alternate #1"
3. M3.0 "Mechanical New Work Controls"
4. M4.0 "Mechanical New Work Communications"
5. M5.0 "Mechanical New Work Balancing"
6. M7.0 "Mechanical New Work Temporary Cooling"

Replace the exact same drawing with the following updated under Amendment #1 12/24/20:

1. M1.0 "Mechanical Roof New Work AHU-1"
2. M2.0 "Mechanical Roof Work Alternate #1"

3. M3.0 “Mechanical New Work Controls”
4. M4.0 “Mechanical New Work Communications”
5. M5.0 “Mechanical New Work Balancing”
6. M7.0 “Mechanical New Work Temporary Cooling”

4. REVISED BID PROPOSAL FORM

Total Base Bid now includes Base Bid Amount, Alternate No. 1 and Allowances. (See attached revised Bid Proposal Form). Contractors must use this revised Bid Proposal Form with their Bid Submission.

Seller must acknowledge receipt of Amendments on PRA Contracts.

SECTION 23 0993
SEQUENCE OF OPERATIONS FOR HVAC CONTROLS

PART 1 - GENERAL

1.1 System Requirements

- A. This system is based on a Native BACnet System either through a JCI FX-80 supervisory controller.
- B. All sensors, power and communication wiring shall be of either Johnson Manufacture and be designed to work in the system through the same Protocol.
- C. Provide a complete scheduling function with 6 month memory and set point settings as noted in “Trending” below.
- D. This system shall be provided with a JACE based full graphics package.
- E. Provide and install an ambient temperature/humidity sensor as noted below and integrate both graphically and operationally.
- I. **Power:** All required control systems power (low and line voltage) shall be provided as part of the ATC contract.

1.2 System Summary

- A. This Section includes control sequences for HVAC systems, subsystems, and equipment.
- B. See Division 23 Section "Instrumentation and Control for HVAC" for control equipment and devices and for submittal requirements.
- C. Note, this is a Basis of Design Johnson Controls ABCS as noted in Specification Section 230900.

1.3 Specific Controls/Mechanical Contract requirements:

- A. COMPLETE new communication cabling for all new equipment (MS/TP Trunk) in and from Contract areas cabling shall be stranded, shielded and Plenum Rated. Operating Protocol shall be BACNET. Communication for all noted HVAC equipment shall be through a new communication line throughout as noted on the contract drawings. Building Supervisory Controller is an existing FX-80 (Johnson Controls ABCS) as noted on Contract Drawings.
- B. The supervisory controller shall integrate an MS/TP Bus around the building to pick up and integrate all noted controller as described below.

- C. The supervisory controller shall be provided with full scheduling, monitoring and trending capabilities (Trending of up to 24 points for a 12-month period of time).
- D. Control Contractor shall provide all control meters and sensors. MC shall install all wells for sensors.
- E. Contract requirements must provide for 16 hours of system training for system operations
- F. Contract requirements require all the points listed below under “Display” be sourced and mapped through the server and graphically represented with building backgrounds.
- G. All units shall be labeled individually on the graphical interface and all indexed references.
- H. All noted controllers are a contract requirement. It is the responsibility of the Mechanical Contractor to provide 120/24V control transformers and all required communication and low voltage power wiring to all required equipment. Each “exposed” controller shall be provided with a transformer and NEMA 1 enclosure “Clamshell” and shall be mounted above the ceiling or in storage and janitorial areas near the serviced equipment.
- I. All sensors and wiring shall be of the same manufacture and be designed to work in the system through the same Protocol.
- J. NOTE: all communication cabling (MS/TP) trunk exterior to building (AHU-1) shall be encased in rigid aluminum conduit until termination point.

1.4 **Contract Requirements Control Contractor AHU-1:**

Contract requirements are such that a NEMA 3R enclosure is mounted to the unit in an accessible location. Refer to Addendum #1 Contract Drawing M3.0 Detail #3. This new controller shall be mounted directly on the enclosure such that all communication and low voltage power requirements can pass through to the AHU without being exposed to the environment. Power for the transformer shall be provided by the electrical contractor through the mechanical contractor. This shall operate off a single pole 20 amp dedicated circuit.

AHU will be provided by the factory with no controls, no terminal board and no sensors. Its is the control contractor’s requirement to provide all communication, sensors, actuators, valves etc.. for a fully operational system.

Provide an FX server graphic that represents the roof structure of the hospital and all the noted smoke damper locations with status as noted below.

NOTE ON EXISTING (or NEW depending on the contract award sequence) roof mounted smoke dampers, these will be monitored through the FX-PCG and then communicated to the server only. Control of these dampers shall be by Simplex

The Mechanical/Controls contractor shall provide and install both chilled water and hot water three way valves in the new pipe enclosure. They shall power them as well through the new controller transformer.

Communication requirements shall be directly with the new FX-80 located in the Animal Hospital basement on the north wall. The MS/TP trunk shall be new and be extended to the new controller. The new controller (FX-PCG2621 w/IOM) shall be mounted at the unit due to the fact that all sensors and low voltage will be provided through the controller.

AHU-1 shall be viewable in all readable points through the FX Server both to the Facilities Department and Hospital Staff.

Command point shall be viewable through an interface area on the FX graphic with the noted output points exposed.

AHU-Operation Equipment Requirements:

- a. **Supply Fan Control:** The supply fan on this unit will be provided with a VFD from the manufacturer and associated interface. Interface with the FX-PCG and the VFD are as follows:
 1. Enable-**BO**
 2. Speed Control-**AO**
 3. Speed feedback-**AI**
 4. Hand Condition-**BI**

- b. **Return Fan Control:** The supply fan on this unit will be provided with a VFD from the manufacturer and associated interface. Interface with the FX-PCG and the VFD are as follows:
 1. Enable-**BO**
 2. Speed Control-**AO**
 3. Speed feedback-**AI**
 4. Hand Condition-**BI**

- c. **Glycol Recovery System:** This system consists of a circulation pump and 2 coils and a fill system. The ATC requirement shall be the following:
 1. Enable: **BO** to SPST –NO RIB
 2. Proof-**BI**-(Current Switch)
 3. Loop Temperature (Thermistor-insertion) at pump discharge-**AI**
 4. Air temperature after each coil (thermistor X2)-**AI/AI**

- d. **Air Flow Sensors:** There shall be (3) airflow stations as provided by the manufacture and are as follows:
 1. Supply/Relief direct bypass-**AI**
 2. System Discharge-**AI**
 3. System Supply-**AI**The BAS shall monitor (4-20ma) and power these sensors.

- e. **Freeze Protection:** Provide and install a Johnson Controls A11A1 Freezestat and integrate to a hard wired shutdown of both the supply and return VFD. Provide a contact to the FX-PCG to notify the server (supervisor) of the fault.-**BO**.

PROJECT No. 71-21-4896-01

230993-3

SEQUENCE OF OPERATIONS FOR HVAC CONTROLS

Amendment #2 12/24/20

- f. **Chilled Water Coil Control Valve:**
1. Provide and install a fully modulating actuator/control valve on the chilled water in the “Dog House”-**AO**
 2. Provide and install a discharge air temperature sensor before and after the chilled water coil.-**AI/AI**.
- g. **Hot Water Coil Control Valve:**
1. Provide and install a fully modulating actuator/control valve on the hot water in the “Dog House”-**AO**
 2. Provide and install a discharge air temperature sensor before and after the chilled water coil.-**AI/AI**.
- h. **Zone Pressure Sensors:** Note to contract drawing M3.0 Detail #3. Provide and power (2) Drwyer Model 616KD-00 differential pressure sensors in locations noted and integrate back to PCG (or directly to FX) **AI/AI**.
- i. **Dampers:** Provide and install 24V actuators on the three dampers/rods being supplied by the manufacture. These dampers to be fully modulating and shall receive a 4 to 20ma signal from the PCG to operate operation or directly by owner.**AO/AO/AO**.
- j. **Smoke Detector:** Once a signal from the simplex fire alarm panel is received either through direct contact with the fire alarm panel or a relay on the actual smoke detector (contractors option), the unit shall disable and all damper shall close in a time delayed process (to allow the VFD’s to ramp down). Unit restart will only allowed once the alarm contact has cleared-**BI**
- k. **Smoke Dampers:** Please note to Contract Drawing M4.0. All exterior mounted smoke dampers will be monitored in position only through the FX-PCG. Positions shall be transmitted to the FX Server through the FX-80-**BI/BI/BI/BI/BI/BI/BI/BI**
- l. **Filter Pressure:** Provide and install a Dwyer series 616W weatherproof pressure transmitter across each filter bank. Incorporate the pressure into the graphical representation of the unit on the server. The following are the filter banks required:
1. AHU Position 5-MERV-8-**AI**
 2. AHU Position 8-MERV 13-**AI**
- m. **Discharge High Pressure Switch:** Provide and install a high pressure switch on the discharge side of the supply fan and set initially to 5”-**AI**

Total:

Binary Output: **4**

Analog Output: **7**

Binary Input: **13**

Analog Input: **17**

Provide Input/Output Modules in Control Panel as needed.

PROJECT No. 71-21-4896-01

230993-4

SEQUENCE OF OPERATIONS FOR HVAC CONTROLS

Amendment #2 12/24/20

Sequence of Operation-Occupied:

1. **Scheduling:** The system shall enable in the occupied mode through the scheduling function of the FX Server.
2. **Supply Fan:** Shall enable and ramp to zone pressure sensor requirements/worst case.
3. **Relief Fan:** Shall ramp to a balanced position.
4. **Outside Air Dampers:** The dampers shall modulate to 100% outsider air and the return and supply fans shall modulate to their set point.
5. **Pressure set points:** The supply fan pressure set point shall be as set by the 2 zone pressure sensors for the supply fan and the return will enable to its balanced position.
6. **Cooling mode** (as set by the zone sensors, communicating through the remaining FX-60 to the server and back to the FX-80). The cooling mode shall be set on command and the unit shall modulate the valve to the coil to maintain a discharge temperature of 55 degrees (adjustable).
7. **Heating Mode:** this mode has 2 functions and they are as follows:
 - a. Maintain a DAT of 40 degrees regardless of the operation of the cooling coil.
 - b. Maintain a DAT of 55 degrees in the normal heating mode (as set by the zone sensors, communicating through the remaining FX-60 to the server and back to the FX-80).
8. **Recovery Coil.** The recovery coil/system shall always be operating when in the occupied mode. With the exception that during a period of time the AHU is in the cooling mode and the outside air temperature is lower than the interior temperature, but greater than 45 degrees and exterior humidity levels are less the 55%. If that condition occurs, the recovery coil will disable until the interior temperature reaches set point. This function will not affect the cooling coil as it will still be modulating the flow to the valve to maintain a 55 degree discharge.

Sequence of Operations-Unoccupied:

1. **Scheduling:** The system shall enable in the un-occupied mode through the scheduling function of the FX Server.
2. **Supply Fan:** Shall enable and ramp to zone pressure sensor requirements/worst case on zone tempering requirements only.
3. **Relief Fan:** Shall not operate in this function.
4. **Outside Air Dampers:** The dampers shall modulate to 20% outsider air and the mixing damper shall modulate to a balanced set point as referenced through the air flow sensor.

PROJECT No. 71-21-4896-01

230993-5

SEQUENCE OF OPERATIONS FOR HVAC CONTROLS

Amendment #2 12/24/20

5. **Pressure set points:** The supply fan pressure set point shall be as set by the 2 zone pressure sensors for the supply fan and the return will enable to its balanced position.
6. **Cooling mode** (as set by the zone sensors, communicating through the remaining FX-60 to the server and back to the FX-80). The cooling mode shall be as requested and programmed by owner at the set point desired.
7. **Heating Mode:** this mode has 2 functions and they are as follows:
 - c. Maintain a DAT of 40 degrees regardless of the operation of the cooling coil.
 - d. Maintain a DAT of 55 degrees in the normal heating mode (as set by the zone sensors, communicating through the remaining FX-60 to the server and back to the FX-80).
8. **Recovery Coil.** The recovery coil/system shall be disabled in the un-occupied mode.

Operational Safeties-occupied or unoccupied (All Alarm conditions will be communicated back to the FX Server):

1. **Smoke Condition:** The unit shall disable and all dampers go to positive closure.
2. **Freeze Protection:** The unit shall disable and all dampers close with the hot and chilled water valves opening full to the coils.
3. **Filer Pressure:** Alarm through FX server to notify client. No operational modifications.
4. **High Supply Static:** Alarm through FX server to notify client. No operational modifications.
5. **Fan Failure (supply).** Not responding to command Alarm through FX server to notify client
6. **Fan Failure (relief).** Not responding to command Alarm through FX server to notify client
7. **Low DAT-Heating Mode:** If the heating coil cannot maintain a Discharge Air Temperature (DAT) greater than 45 degrees an alarm will notify the owner.
8. **High DAT-Cooling Mode:** If the cooling coil cannot maintain a Discharge Air Temperature (DAT) lower than 65 degrees an alarm will notify the owner.

END OF SECTION

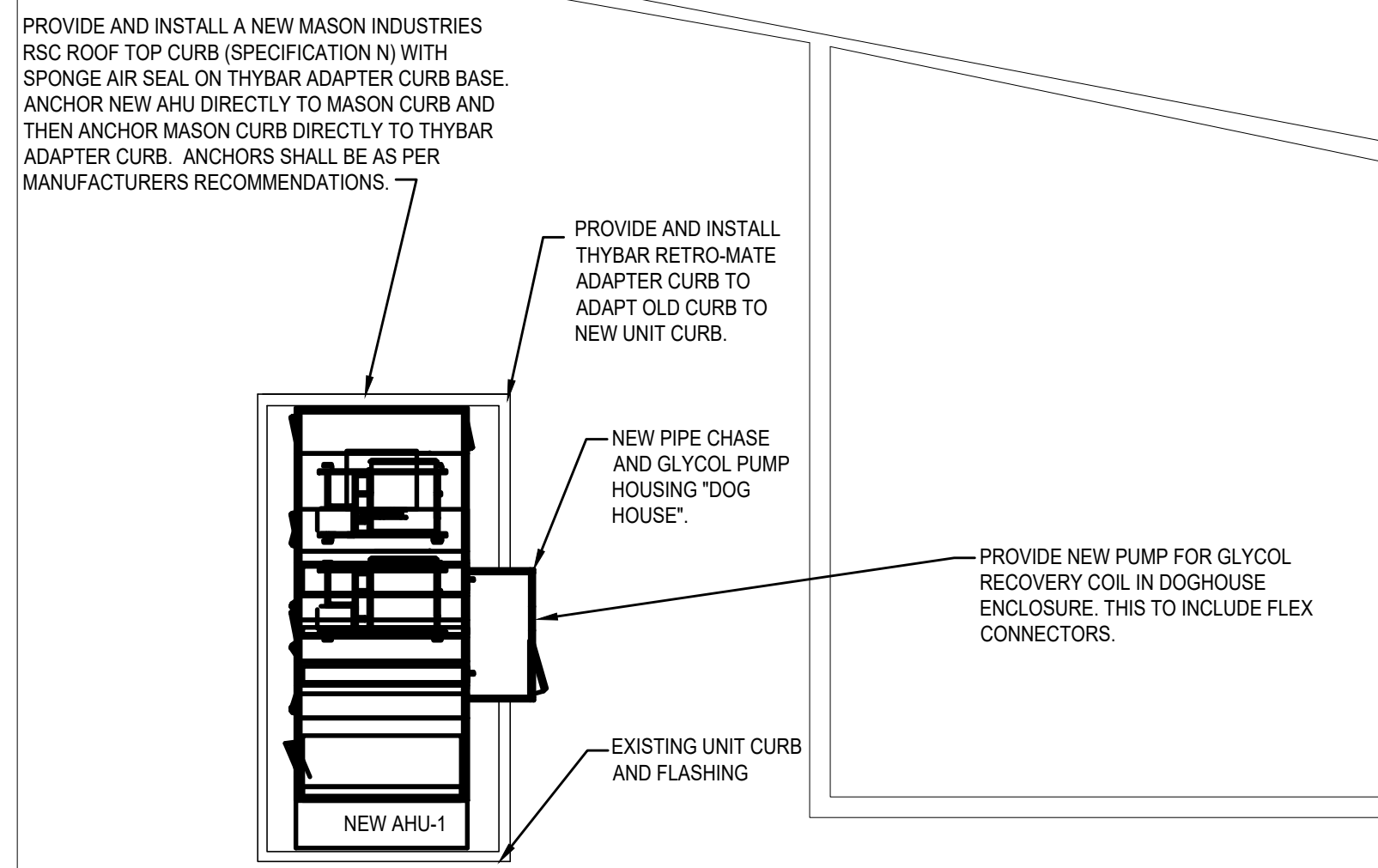

MECHANICAL ROOF PLAN - AHU NEW WORK

1
M1.0
1/8" = 1'-0"

MECHANICAL AHU COIL CONNECTION REQUIREMENTS

4
M1.0
NOT TO SCALE

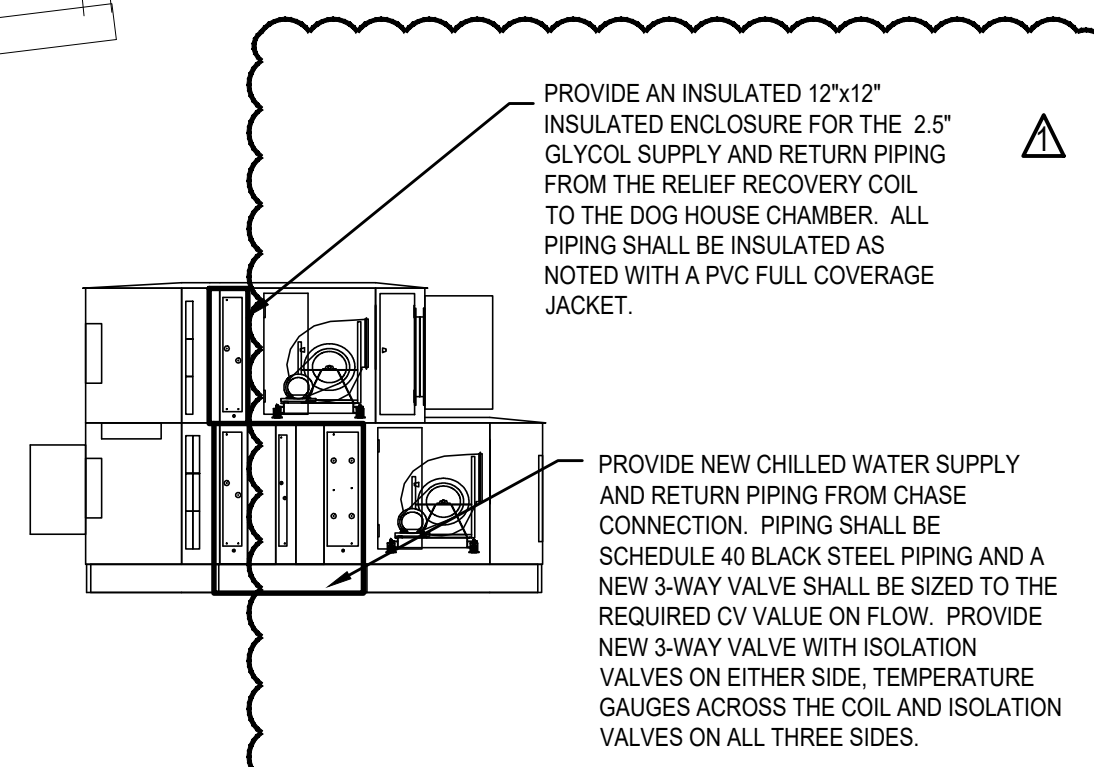

AHU NEW WORK REQUIREMENT

NOTES:

- COORDINATE WITH ARCHITECT AND OWNER ON SYSTEM INSTALLATION IN A 3 WEEK LOOK AHEAD SCHEDULE.
- COORDINATE PROVISION AND ARRIVAL OF TEMPORARY AIR HANDLING UNIT FROM AGREKKO RENTAL. REFERENCE BUDGET QUOTE 331. REPRESENTATIVE MATT WAGNER/ 877-244-7356/ MATT.WAGNER@AGREKKO.COM.
- AHU-1 AIRFLOW MUST NOT BE DOWN MORE THAN A 4 HOUR TIME PERIOD BETWEEN ENERGIZING AND CONNECTING THE TEMPORARY UNIT AND REMOVING THE EXISTING AND THEN FROM REMOVING THE TEMPORARY AND CONNECTING THE NEW UNIT.
- PROVIDE AND INSTALL A NEW 2" HOT WATER FULL MODULATION 3-WAY VALVE IN THE "DOG HOUSE" THAT IS FULLY ACCESSIBLE.
- PROVIDE AND INSTALL A NEW CHILLED WATER 3 WAY FULL MODULATING VALVE IN "DOG HOUSE" WITH HOT WATER VALVE.
- PROVIDE AND INSTALL A GLYCOL CIRCULATION PUMP IN THE "DOG HOUSE" AND CONNECT TO BOTH SUPPLY AND RELIEF COILS.
- PROVIDE A CONTRACT (AS PART OF THE MECHANICAL BID) WITH SIMPLEX. CONTACT TONY DIBONVENTURA AT 215-317-7862. SIMPLEX CONTRACT REQUIREMENTS SHALL BE TO PROVIDE NEW DUCT DETECTOR FOR MC INSTALLATION AND ALL NEW POWER AND COMMUNICATIONS WIRING FOR SMOKE DAMPERS.
- ALL NEW DUCTWORK SHALL BE INSULATED WITH 2" RIGID INSULATION WITH A VENTURE CLAD PLUS 1579CW SEALANT MEMBRANE.
- PROVIDE AND INSTALL A THYBAR ADAPTER CURB ON EXISTING, ANCHOR SECURELY TO EXISTING REMAINING CURB.
- PROVIDE NEW VIBRATION CURB ON THYBAR CURB FOR MOUNTING NEW AHU.
- CONNECT RELIEF DUCTWORK AND REMOVE TEMPORARY BACK DRAFT DAMPER.
- SEAL AND INSULATE RELIEF DUCTWORK CONNECTION.
- CONNECT SUPPLY DUCTWORK, SEAL AND INSULATE.

AXIOM GLYCOL FEEDER DETAIL

2
M1.0
NOT TO SCALE

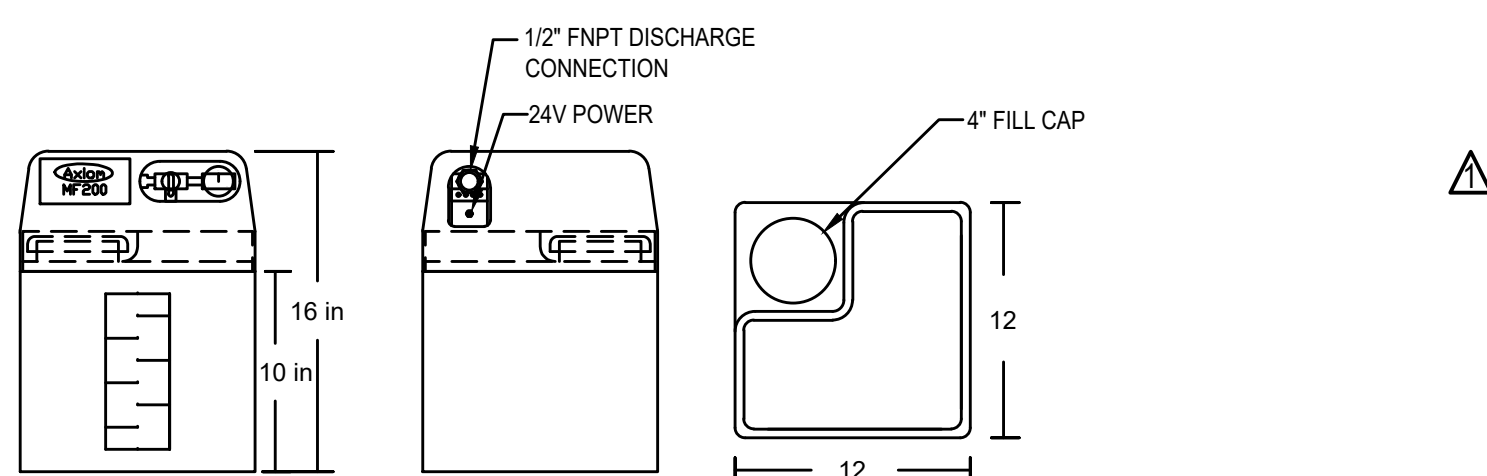

- MOUNT INSIDE PROVIDED DOG HOUSE.
- MC TO PROVIDE 24V POWER BY INSTALLING A TRANSFORMER IN A NEMA ENCLOSURE AND PROVIDING CONTINUOUS 24V POWER TO FEEDER.
- CONNECT 2" FEED LINE FROM FEEDER TO CIRCULATION PIPE AS NOTED.
- MOUNT SUCH THAT THE FILL CAP HAS ACCESS.

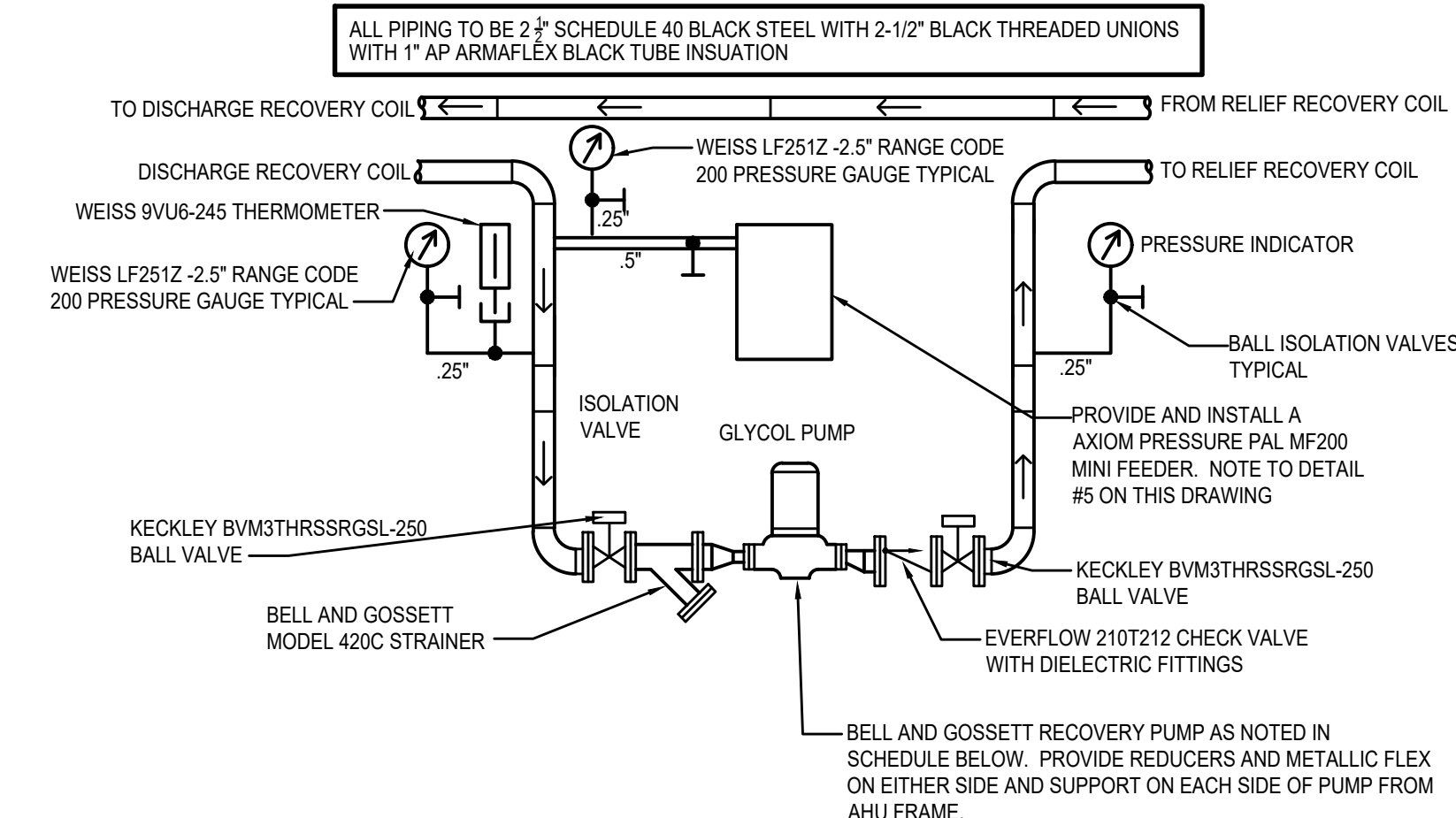

MECHANICAL GLYCOL PUMP CONNECTION DETAIL

3
M1.0
NOT TO SCALE

MECHANICAL GLYCOL PUMP CONNECTION DETAIL

5
M1.0
NOT TO SCALE

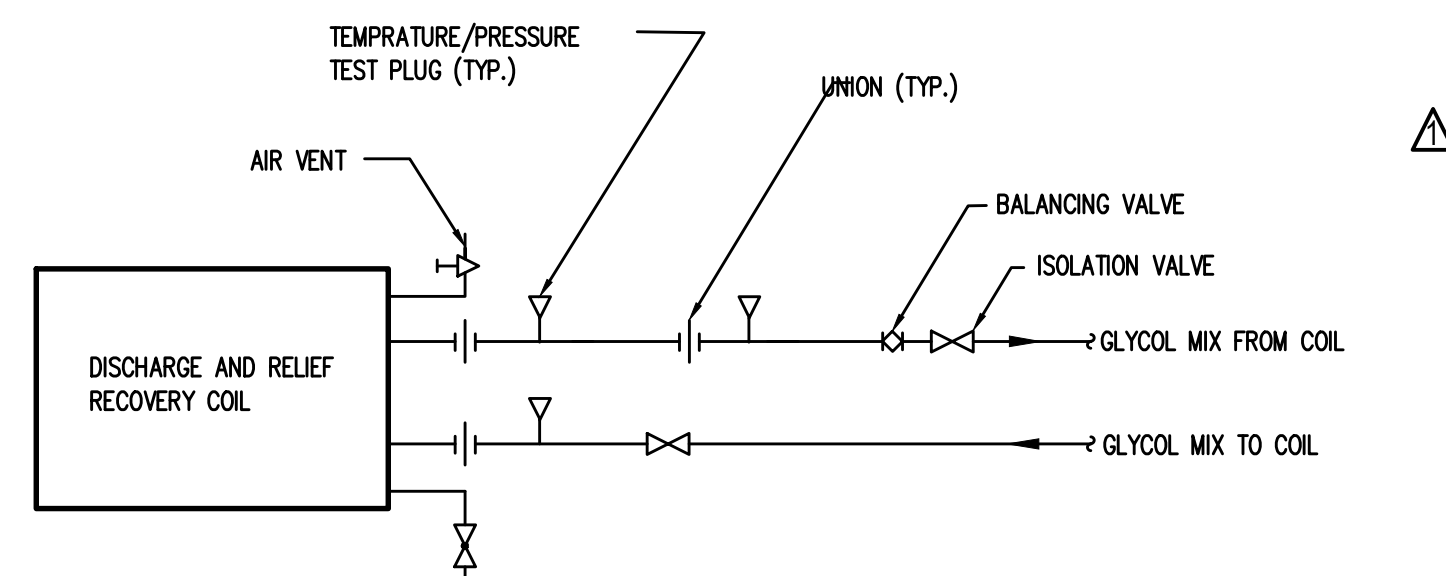

MECHANICAL ROOF PLAN - AHU DUCTWORK NEW WORK

6
M1.0
1/8" = 1'-0"

NOTE: THERE IS BASE BID DUCT WORK REQUIREMENTS AS NOTED ABOVE. THE NEW UNIT DIFFERS IN DUCT CONNECTIONS SUCH THAT DUCT MODIFICATIONS WILL BE REQUIRED AS NOTED ABOVE FOR THE BASE BID. TOTAL DUCT REPLACEMENT SHALL BE UNDER ALTERNATE #1. ALL REPLACEMENT (NEW) DUCT SHALL BE G90 SCHEDULE 20 GALVANIZED STEEL WITH A 4" PRESSURE CLASS. ALL INSULATION SHALL BE 2" BOARD INSULATION WITH 3M VENTURE GLAD INSULATING JACKET TAPE 1577CW.

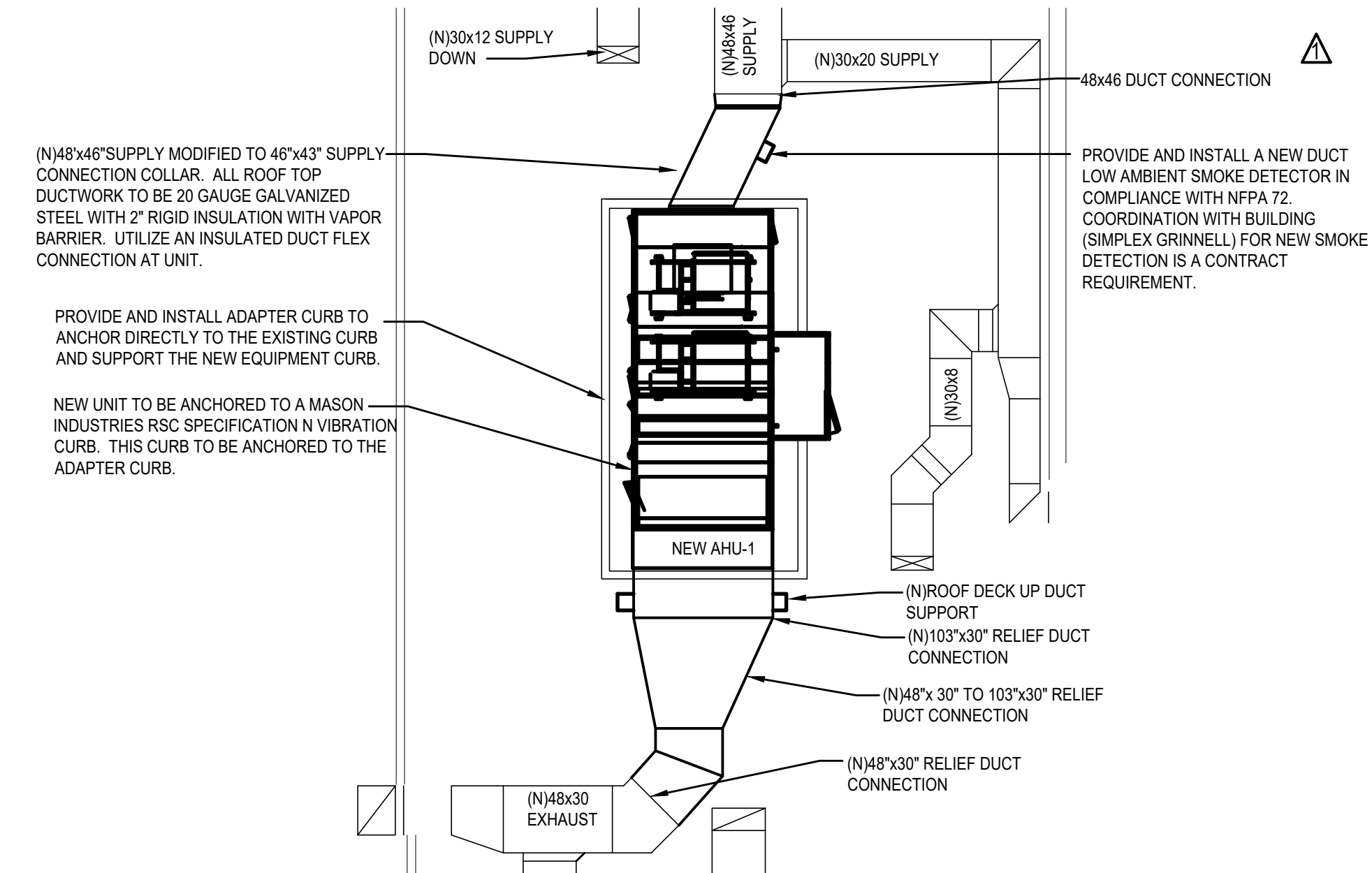

AHU-1 CURB VIBRATION ISOLATOR DETAIL

7
M1.0
NOT TO SCALE

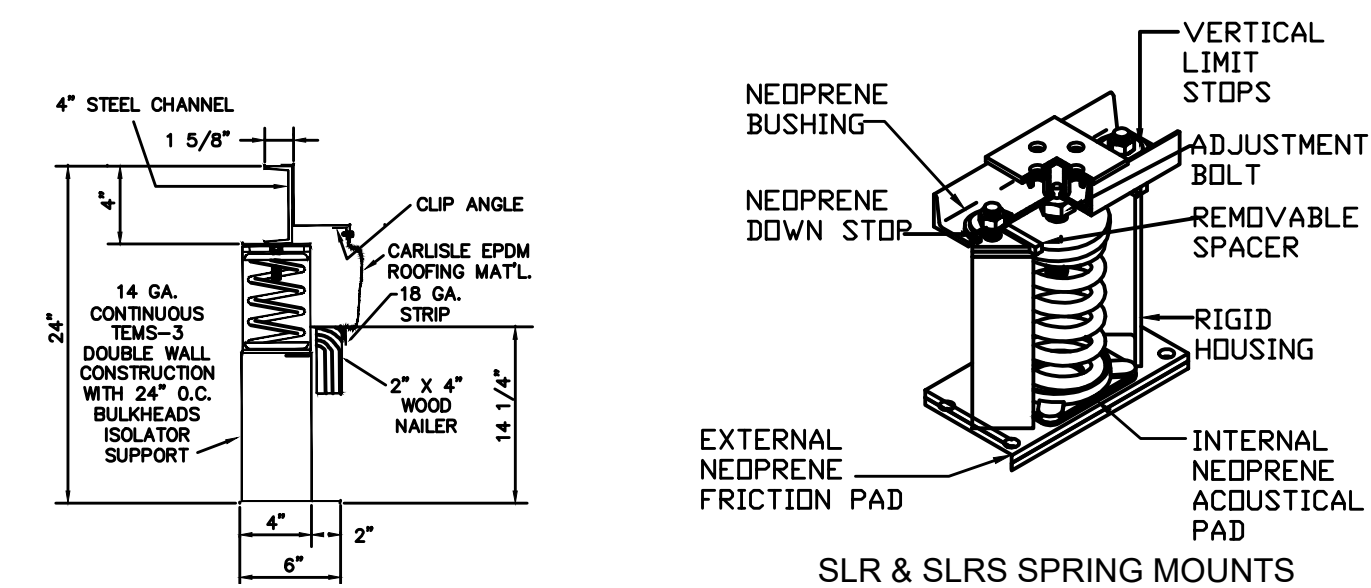

AHU-1 MECHANICAL ADAPTER CURB CONNECTION

8
M1.0
NOT TO SCALE

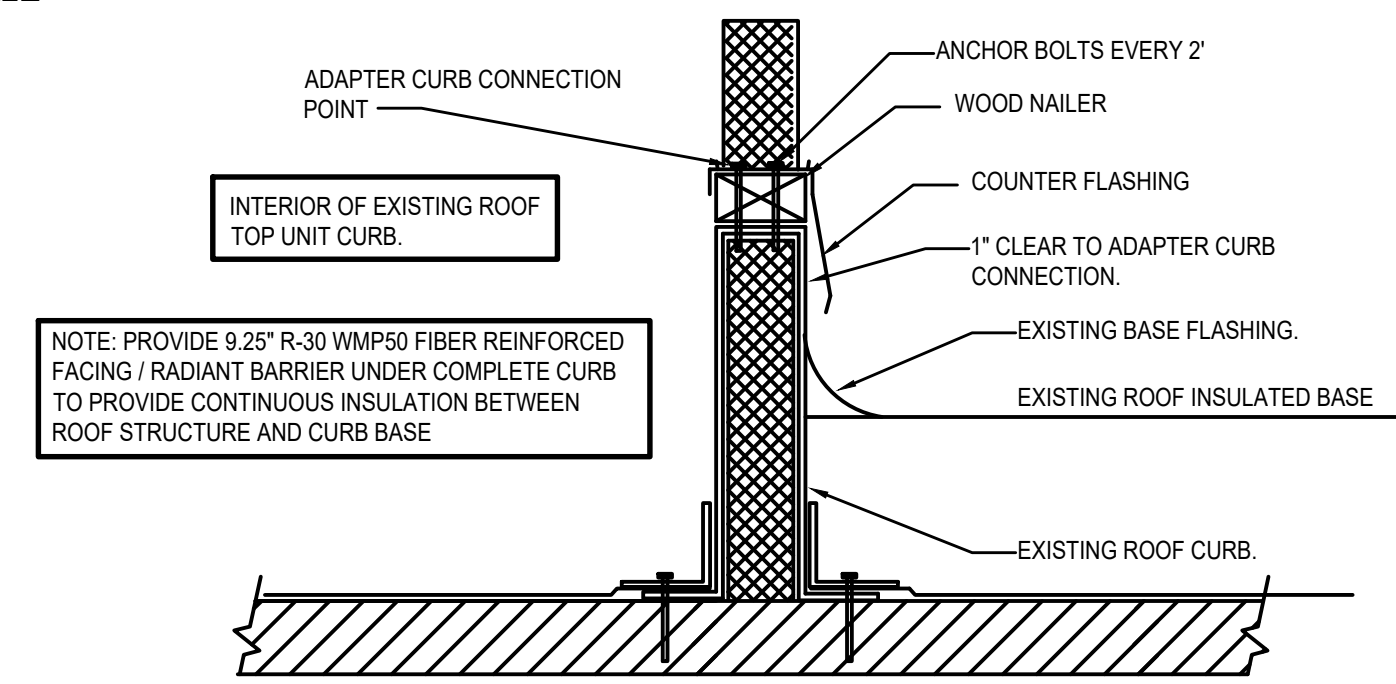

ROOFTOP UNIT (AHU) SCHEDULE TRANE MODEL CSAA035-CUSTOM

UNIT NO.	LOCATION	SERVICE	SUPPLY FAN DATA		RETURN/RELIEF FAN DATA				ENERGY RECOVERY COIL DATA-THERE ARE 2 OF THESE (SUPPLY AND RELIEF DUCT)										SYSTEM COIL DATA						ELECTRICAL DATA					OPER. WT. (Lbs)															
			CFM	MIN. OA	STATIC PRESSURE	RPM	HP	CFM	STATIC PRESSURE	RPM	HP	SYSTEM GPM	SYSTEM CFM SUPPLY	SYSTEM CFM RELIEF	MAX. PD AIR SUPPLY/DISCHARGE	SUMMER		WINTER		MAX. PD WATER SUPPLY/DISCHARGE	RECOVERY PUMP DATA			CHILLED WATER COIL DATA			HEAT WATER COIL DATA				SERVICE CIRCUITS	V	Ø	Hz	FLA	MCA	MOP								
																ENTERING DB/WB	LEAVING DB/WB	ENTERING DB/WB	LEAVING DB/WB		GPM	WPD	RPM	HP	MANUFACTURER AND MODEL	GPM	WPD	APD	ENTERING AIR DRY BULB									ENTERING AIR WET BULB	LEAVING AIR DRY BULB	LEAVING AIR WET BULB	ENTERING WATER TEMP. F.	LEAVING WATER TEMP. F.	ENTERING WATER TEMP. F.	LEAVING WATER TEMP. F.	#1 RECOVERY PUMP
AHU-1	ROOF	HOSPITAL	16,740	100%	4.0"	8.75"	1,792	30	13,810	3.0"	4.36"	1,465	20	106	16,740	13,810	.477/35"	86/76	85/70	30/21	42/42	15/15" SUMMER	106	40	1150	2	BELL AND GOSSETT E-80C 5X5X7	256.80	8.21	0.905	86.97	75.95	53.0	52.9	633.22	1312.88	20	1.74	0.106	30.42	58.70	160.0	105.72	513.41	15,012

- REQUIREMENT NOTES:
- CONTROLS: THIS UNIT TO BE PROVIDED FROM THE MANUFACTURER (TRANE) WITH NO CONTROLS WITH THE EXCEPTION OF (3) DIFFERENTIAL PRESSURE AIR FLOW STATIONS (4-20MA OUTPUT/24V POWER INPUT). CONTROLS CONTRACTOR SHALL CONVERT DIFFERENTIAL PRESSURE READING TO CFM AND DISPLAY ON FX SERVER AHU GRAPHIC. MANUFACTURER(TRANE) ALSO TO PROVIDE (2) FULL RANGE VFD'S WITH ENABLE (DI), SPEED MODULATION (AI), FEEDBACK (AO) AND ALARM CONDITION (DO).
 - TRANE SHALL PROVIDE DAMPER OPERATION RODS FOR THE OUTSIDE AIR ISOLATION DUCT (OF WHICH THE UNIT SHALL BE PROVIDED WITH), RELIEF/RETURN MIXING DAMPER AND DISCHARGE/RELIEF DAMPER (OF WHICH ONE IS REQUIRED).
 - THE AHU SHALL BE BUILT FOR EXTERIOR OPERATION WITH 2" FOAM INJECTED R-13 WITH THERMAL BREAK INSULATION IN THE SURROUNDING ENCLOSURE.
 - THE AHU WILL BE PROVIDED WITH A SEPARATE COMPARTMENT "DOG HOUSE" AS NOTED ON CONTRACT DRAWINGS. THIS SHALL BE AN INSULATED ENCLOSURE WITH PIPE TERMINATIONS FOR BOTH SUPPLY AND RETURN MOUNTED RECOVERY COILS. THE MECHANICAL CONTRACTOR SHALL BE RESPONSIBLE TO PLACE, ANCHOR AND PIPE IN THE GLYCOL PUMP (WITH MINI FEEDER) AS NOTED IN DETAIL. ALL MUST FIT AND BE SUPPORTED IN THE ENCLOSURE WITH MAINTENANCE CLEARANCE.
 - THE AHU SHALL BE PROVIDED WITH A MERV 8 FILTER BANK IN POSITION 5 AND A MERV 13 IN POSITION 8 W/PREFILTER.
 - ALL SYSTEM ACCESS ON UNIT SHALL BE DESIGNED TO OPEN TO THE EAST OF THE UNIT WITH THE EXCEPTION OF THE EXHAUST/RELIEF FAN.
 - THE CONTROLS/MECHANICAL CONTRACTOR IS RESPONSIBLE FOR MOUNTING ALL REQUIRED SENSORS, RELAYS AND INTERFACE WITH THE FACTORY SUPPLY AND RETURN DUCT VFD'S.
 - THE ADAPTER CURB PROVIDED SHALL BE BY THYBAR AND MUST BE APPROVED BY TOZOUR TRANE AS WELL AS ENGINEER BEFORE PROVISION AND INSTALLATION. THE CONTRACTOR SHALL VERIFY ALL SIZING BEFORE SUBMITTAL SUBMISSION.
 - PROVIDE AND INSTALL (2) CORNER MAINTENANCE LIGHTS ON OPPOSITE CORNERS TO BE WIRED BY ELECTRICIAN.

REVISIONS

ISSUE	DATE	REVISIONS
1	11/23/20	FOR BID
2	12/24/20	AMENDMENT #1



PHILADELPHIA

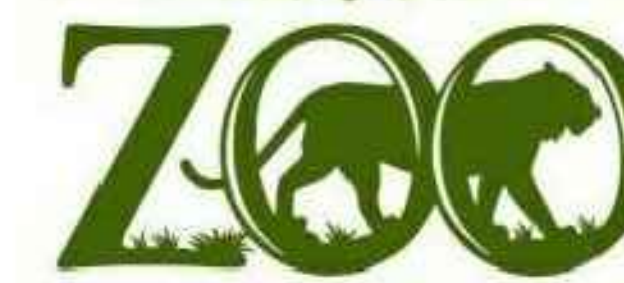

AMERICA'S FIRST ZOO

MP Engineer

Wick Fisher White

Federal Reserve Bank Building

100 N. Independence Mall West

Suite 5 SE

Philadelphia, PA 19106

Tele: 215-627-0200

WFW PROJECT # - 190019

PROJECT COORDINATOR:

SEALS

PHILADELPHIA PENNSYLVANIA

CITY OF PHILADELPHIA DEPARTMENT OF PUBLIC PROPERTY

1400 JFK BOULEVARD CITY HALL - ROOM 701

PHILADELPHIA PENNSYLVANIA

PROJECT TITLE

Animal Hospital - AHU-1 Replacement

DRAWING TITLE

MECHANICAL ROOF NEW WORK AHU-1

PROJECT NO.

71-21-4869-01

DRAWING NO.

DATE

11/23/20

SCALE

AS NOTED

DRAWN BY

AO

CHECKED BY

AO

OPER. WT. (Lbs)

15,012

NOTE: ALL DIMENSIONS AND CONDITIONS SHALL BE VERIFIED BY THE CONTRACTOR AT THE SITE BEFORE PROCEEDING WITH THE WORK.

M1.0

SECTION 00411
BID PROPOSAL FORM

PHILADELPHIA REDEVELOPMENT AUTHORITY

**PHILADELPHIA ZOO – ANIMAL HOSPITAL
3400 W. GIRARD AVENUE
MECHANICAL EQUIPMENT REPLACEMENT**

THIS BID FORM IS COMPLETE, AND MUST NOT BE SEPARATED. IF ANY SHEET OR SHEETS ARE DETACHED WHEN SUBMITTED AS A BID, THE PHILADELPHIA REDEVELOPMENT AUTHORITY RESERVES THE RIGHT TO REJECT YOUR BID.

FIRM NAME

FIRM ADDRESS

FEDERAL EIN

PHILADELPHIA BUSINESS TAX ID

TOTAL BASE BID

To the Philadelphia Redevelopment Authority:

I, the undersigned Bidder, hereby propose to furnish all the labor, materials and equipment, perform the whole of the work, and submit to all conditions, as represented, intended and implied, both particularly and generally, by the Plans, Special Specifications, Standard Specifications, Standard Details, Standard Contract Requirements, Form of Agreement, the Ordinance authorizing the work and this bid at the prices herein stated, and agrees that each item bid shall be complete in itself, and the Philadelphia Redevelopment Authority may increase or diminish the amount of work thereunder, or omit the item without invalidating the unit price bid for it or any other item, on the following terms to wit:

A. BID AMOUNT

I will complete the Work in accordance with the Contract Documents for the following Bid Amount as defined in Section 00700, Standard Contract Requirements. (Insert Bid Amount in words as well as figures.)

(1) BASE BID AMOUNT: _____

DOLLARS, \$ _____

(2) ALTERNATE No. 1: _____

DOLLARS, \$ _____

(3) ALLOWANCE: Bidders are to include the amount equal to Two Percent (2%) of their base bid amount for payment of Permit and License fees to all regulatory agencies. Refer to Allowances, Section 01210 for more details.

ALLOWANCE AMOUNT: _____

DOLLARS, \$ _____

TOTAL BASE BID:

Base Bid plus Alternate No. 1 and Allowance(s): _____

DOLLARS, \$ _____

Please provide the following pricing for Alternates No. 2 and 3: (The pricing will not be included in the Total; Base Bid amount.

ALTERNATE No. 2: _____

DOLLARS, \$ _____

ALTERNATE No. 3: _____

DOLLARS, \$ _____

C. PERFORMANCE OF THE WORK BY CONTRACTOR:

I, the undersigned Contracting Bidder, am required to perform work on the site with its own workforce equal to at least twenty percent (20%) of the original total contract price exclusive of profit, overhead and the costs of procuring insurance and bonds. I, the undersigned Contracting Bidder, shall submit with its bid a complete description of the work that will be performed (e.g., earthwork, paving, brickwork, roofing, etc.), the percentage of the total contract this work represents, and the estimated dollar value thereof.

I shall perform the following work: _____

Percentage of the total contract to be performed by Contracting Bidder: _____

Estimated cost of work to be performed by Contracting Bidder: \$ _____

D. COMPLETION

I will substantially complete the Work, ready for final payment, in accordance with the Contract Documents within 150 consecutive calendar days counting from the date stated in the Notice to Proceed.

E. ADDENDA

Bidder must attach Addendum Acknowledgement sheets for all Addenda, if applicable.

Addendum #1, dated: N/A

EXECUTION OF CONTRACT

This contract consists of the Standard Contract Requirements; the Department’s Standard Details and Specifications, as they apply; the Department’s General Bidding and Contract Requirements; the Technical Specifications; the Bid; the Plans with all of the notes thereon (excluding any records or reports of test borings, underground structures, and test piles); any additional exhibits or attachments to any of the foregoing; and any addenda thereto issued by the City (collectively, the “Contract”).

NOTE: ANY CONTRACT THAT IS NOT EXECUTED IN ACCORDANCE WITH THE INSTRUCTIONS PROVIDED BELOW, MAY, IN THE SOLE DISCRETION OF THE PHILADELPHIA REDEVELOPMENT AUTHORITY, BE REJECTED.

SIGNING OF CONTRACT

If Contractor is an INDIVIDUAL or a PARTNERSHIP, date and sign the Contract here, with original signatures, in ink.

This _____ day of _____ 2021

(Signature of Owner, Partner)

(Type or Print Name and Title)

(Business Name of Bidder)

If Contractor is a CORPORATION, date and sign the Contract here with original signatures, in ink, by (a) President or Vice-President of the corporation AND (b) Secretary, Assistant Secretary, Treasurer or Assistant Treasurer of the corporation; and (c) affix the seal of the corporation. If the Contract is not signed by the President or Vice-President; and Secretary, Assistant Secretary; Treasurer or Assistant Treasurer, attach a duly certified corporate resolution authorizing the person signing in place of such officers to execute this Contract for the corporation.

This _____ day of _____ 2021

CORPORATE SEAL

(Corporate or Business Name of Bidder)

(Address, Including Zip Code)

(Telephone Number)

(Signature of President or Vice President)

(Signature of Secretary, Asst. Secretary, Treasurer or Assistant Treasurer)

(Type or Print Name and Title)

(Type or Print Name and Title)