

Attachment 2c

Specifications Appendices :

Appendix A: LEED v4.1 Project Checklist

Appendix B: Interior & Exterior Lighting Fixture Cut Sheets

Appendix C: Geotechnical Soils Investigation Report

Appendix A - LEED Project Checklist

LEED FOR CORE & SHELL

Version: LEED BD+C

PROJECT NAME: Francis J Myers

PROJECT CHECKLIST

Project Phase: CD

PROJECT ADDRESS: 5801 KINGSESSING AVE PHILADELPHIA, PA 19143

Certification Target: Silver (Required), Gold (Goal)

LAST UPDATE: 4/7/2023

Certification Pathway Assumptions	
Certified	GUARANTEED* ITEMS ALREADY IN DESIGN
Silver	NO/LOW COST DESIGN MODIFICATIONS, CONTRACTOR TRACKING
Gold	MODERATE ADDITION IN COST/EFFORT
Platinum	SIGNIFICANT/LARGE ADDITION IN COST/EFFORT

Certified	Silver	Gold	Platinum	N/A
43	56	65	86	47

Certified 40-49 points Silver 50-59 points Gold 60-79 points Platinum 80-110

C	S	G	P	N/A	Confidence	LEED Version	Category	Credit	Credit Name	Phase	Points	LEED Standard	Responsible Party
Y				P			PI	Prereq	Project Information	D		Provide summary project data, drawings and schedules.	db+
1				0	Yes	v4	IP	Credit 1	Integrative Process	D	1	Perform preliminary energy model and water budget before the completion of SD and document in OPR & BOD; provide completed Integrative Process worksheet.	Arch MEP
LT CATEGORY LOCATION AND TRANSPORTATION													
1				0	Yes	v4	LT	Credit 2	Sensitive Land Protection	D	1	Locate the development footprint on land that has been previously developed - OR - does not meet LEED criteria for sensitive land (prime farmland, floodplains, habitat for threatened species, near water bodies, in or near wetlands)	LEED
1				1	Yes	v4	LT	Credit 3	High Priority Site	D	2	Locate the project on a site with priority designation (1 pts) - OR - brownfield site where contaminated soil/groundwater remediation is required (2 pts)	LEED
5				0	Yes	v4	LT	Credit 4	Surrounding Density and Diverse Uses	D	5	Locate on a site with an existing density of 22,000sf/acre - 35,000 sf/acre and within 1/2 mile of 4-8 basic services	Arch
3				2	Yes	v4	LT	Credit 5	Access to Quality Transit	D	5	Locate project within 1/2 mile of a rail station or ferry terminal that meets min. daily transit service - OR - 1/4 mile of bus, streetcar or rideshare that meets min. daily transit service.	Arch
				1		v4	LT	Credit 6	Bicycle Facilities	D	1	Provide short term (2.5% peak visitors) and long term (5% all regular occupants) bike parking within 100ft of any main entrance, FTE showers, and access to bicycle network.	Arch
1				0	Yes	v4.1 (Oct '21)	LT	Credit 7	Reduced Parking Footprint	D	1	Provide 30% reduction in parking capacity from ITE base ratios and do not exceed minimum local code requirements it.	Arch
				1		v4.1 (Oct '21)	LT	Credit 8	Green Vehicles	D	1	Provide preferred parking for electric vehicle supply equipment (EVSE) for 5% (or 2 spaces, whichever is greater) of parking spaces - OR - make 10% of parking spaces (or at least 6 spaces) EV ready for future use.	Arch MEP
SS CATEGORY SUSTAINABLE SITES													
Y				P			SS	Prereq 1	Construction Activity Pollution Prevention	C		Create and implement erosion control plan that meets the 2003 EPA Construction General Permit.	Civil
	1			0	Yes	v4	SS	Credit 1	Site Assessment	D	1	Complete comprehensive site survey; topography, hydrology, climate, vegetation, soils, human use and human health effects.	Arch Landscape
				2		v4.1 (Oct '21)	SS	Credit 2	Site Development - Protect or Restore Habitat	D	2	Preserve and protect 40% of greenfield area (if present) from development/construction AND restore 15% (1pt) or 25% (2pts) of previously developed site with native/adapted plants - OR - provide \$0.40/sf to accredited land trust (1pt).	Landscape
1				0	Yes	v4.1 (Oct '21)	SS	Credit 3	Open Space	D	1	Provide outdoor space greater than or equal to 30% of the total site area (including building footprint), with min. 25% vegetated. Projects with 1.5 FAR may count physically accessible vegetated roofs.	Landscape
				3		v4.1 (Oct '21)	SS	Credit 4	Rainwater Management	D	3	Retain runoff for the 80th percentile (1pt) or 85th percentile (2pts) or 90th percentile (3pts) using low-impact development (LID) and green infrastructure (structural or non-structural). For zero lot line, reduce the rainfall event for the 70th percentile (1pt), 75th percentile (2pts) or 80th percentile (3pts)	Civil
2				0	Yes	v4	SS	Credit 5	Heat Island Reduction	D	2	Meet high albedo requirements for roof and site (2pts) - OR - place a minimum of 75% parking under cover (1pt).	Arch Landscape
	1			0	Likely Maybe	v4	SS	Credit 6	Light Pollution Reduction	D	1	Meet uplight and light trespass requirements, and do not exceed exterior signage luminance requirements.	Lighting
WE CATEGORY WATER EFFICIENCY													
Y				P			WE	Prereq 1	Outdoor Water Use Reduction	D		Reduce outdoor water use by 30% over the baseline specified in LEED.	Landscape
Y				P			WE	Prereq 2	Indoor Water Use Reduction	D		Reduce indoor water use by 20% over the baseline specified in LEED, use fixtures with WaterSense label, and meet requirements for process water use. Cooling tower must have make-up water submetering	MEP
Y				P			WE	Prereq 3	Building-Level Water Metering	D		Install permanent water meters for building and grounds, and commit to share data with USGBC for 5 years.	MEP OWNER
2				0	Yes	v4.1 (Oct '21)	WE	Credit 1	Outdoor Water Use Reduction: 50% / 75% / 100%	D	2	No irrigation required (2 pts) - OR - Reduce potable water used for irrigation by 50% (1 pt)	Landscape
		2		4	Unlikely Maybe	v4	WE	Credit 2	Indoor Water Use Reduction: 25% / 30% / 35% / 40% / 45% / 50%	D	6	Reduce building water use over LEED baseline.	MEP
				2		v4.1 (Oct '21)	WE	Credit 3	Optimize Process Water Use	D	2	Conduct a water analysis to optimize cooling tower cycles. Maximizing cycles (1pt), exceed maximum by 25% / 30% or 20% / 30% non-potable water use (2 / 3pts). - OR - optimize cooling tower water use by 25% / 50% / 100% - OR - use 20% / 30% / 40% recycled water for process water use.	MEP
	1			0	Yes	v4	WE	Credit 4	Water Metering	D	1	Install permanent water meters for two or more water subsystems.	MEP
EA CATEGORY ENERGY EFFICIENCY													
Y				P			EA	Prereq 1	Fundamental Commissioning and Verification	C		Engage commissioning agent by end of DD, develop and execute a commissioning plan, and prepare O&M plan for current facilities.	CxA
Y				P			EA	Prereq 2	Minimum Energy Performance	D		Reduce energy cost by 5%, compared to ASHRAE 90.1-2010, Appendix G; meet mandatory provisions of ASHRAE 90.1-2010. - OR - Comply with HVAC and service water heating requirements for the climate zone in ASHRAE 50% Advanced Energy Design Guide, and meet ASHRAE 90.1-010 mandatory and prescriptive provisions.	MEP
Y				P			EA	Prereq 3	Building-Level Energy Metering	D		Install meters to provide data on total energy consumption, and commit to share data with USGBC for 5 years.	MEP OWNER
Y				P			EA	Prereq 4	Fundamental Refrigerant Management	D		Eliminate CFCs in building HVAC&R, and complete CFC phase-out conversion before project completion for any CFC equipment to remain.	MEP
3			3	0	Yes	v4	EA	Credit 1	Enhanced Commissioning	C	6	Complete CD review, post occupancy review, and recommissioning manual (3pts), and develop monitoring procedures (+1pt) - AND/OR - complete envelope Cx (+2pts)	CxA
3				0	Yes	v4	EA	Credit 2	Optimize Energy Performance: 3% / 5% / 7%	D	3	Reduce building energy cost by 3% / 5% / 7% compared to ASHRAE 90.1-2010, Appendix G	MEP
3				0	Yes	v4	EA	Credit 2	Optimize Energy Performance: 9% / 11% / 13%	D	3	Reduce building energy cost by 9% / 11% / 13% compared to ASHRAE 90.1-2010, Appendix G.	MEP
2	1			0	Yes	v4	EA	Credit 2	Optimize Energy Performance: 15% / 17% / 19%	D	3	Reduce building energy cost by 15% / 17% / 19% compared to ASHRAE 90.1-2010, Appendix G.	MEP
	2		1	0	Unlikely Maybe	v4	EA	Credit 2	Optimize Energy Performance: 21% / 23% / 26%	D	3	Reduce building energy cost by 21% / 23% / 26% compared to ASHRAE 90.1-2010, Appendix G.	MEP
			3	0	Unlikely Maybe	v4	EA	Credit 2	Optimize Energy Performance: 29% / 32% / 35%	D	3	Reduce building energy cost by 29% / 32% / 35% compared to ASHRAE 90.1-2010, Appendix G.	MEP
			3	0	Unlikely Maybe	v4	EA	Credit 2	Optimize Energy Performance: 39% / 43% / 47%	D	3	Reduce building energy cost by 39% / 43% / 47% compared to ASHRAE 90.1-2010, Appendix G.	MEP
1				0	Yes	v4	EA	Credit 3	Advanced Energy Metering	D	1	Install meters for tenant spaces to independently meter energy consumptions for all systems dedicated to tenant space, with minimum of one meter per energy source per floor. Install advanced metering for base-building energy sources, per reference guide.	MEP
				2	Unlikely Maybe	v4	EA	Credit 4	Demand Response	D	2	Participate in existing DR program to shed 10% of estimated peak electricity demand (2 pts) - OR - design for future DR response when utility program is available (1 pt)	MEP

				3	Unlikely Maybe	v4	EA	Credit 5	Renewable Energy Production: 1% / 3% / 5%	D	3	Use renewable energy systems to offset 1% / 3% / 5% of total building energy costs	MEP
				1	Unlikely Maybe	v4	EA	Credit 6	Enhanced Refrigerant Management	D	1	Select refrigerants with low global warming potential and ozone depletion potential.	MEP
		5		0	Unlikely Maybe	v4.1 (Oct '21)	EA	Credit 7	Green Power and Carbon Offsets: 50% / 100%	C	5	Purchase green tariff program or RECs and/or carbon offsets to offset 50% / 100% of total energy use	Owner
MR CATEGORY MATERIALS & RESOURCES													
Y					P		MR	Prereq 1	Storage and Collection of Recyclables	D		Provide space for the collection and storage of paper, cardboard, glass, plastic, metals, and at least two of the following: batteries, mercury-containing lamps, and electronic waste.	Arch
Y					P		MR	Prereq 2	Construction and Demolition Waste Management Planning	C		Develop and implement a construction and demolition waste management plan.	GC
	2		3	0	Likely Maybe	v4.1 (Oct '21)	MR	Credit 1	Building Life-Cycle Impact Reduction	C	5	Reuse of historic building or renovation of abandoned building (5 pts) - OR - reuse 15%/30%/45%/60%/70% of structural/enclosure/permanent interior elements (2-5 pts).	Arch / GC
	1			0	Yes	v4.1 (Oct '21)	MR	Credit 2.1	BPDO - Environmental Product Declarations	C	1	Use 20 products sourced from five different manufacturers that meet disclosure criteria	Arch / GC
			1	0	Unlikely Maybe	v4.1 (Oct '21)	MR	Credit 2.2	BPDO - Multi-Attribute Optimization (Option 2)	C	1	Use products that demonstrate impact reduction below industry average (in 3 criteria categories) for 50%, by cost, of permanently installed materials.	Arch / GC
			1	1	0	Unlikely Maybe	MR	Credit 3	BPDO - Sourcing of Raw Materials	C	2	Use 20 products sourced from five different manufacturers that meet raw materials criteria - AND/OR - use products that meet at least one of the responsible extraction criteria for at least 25%, by cost, of the total value of permanently installed building products.	Arch / GC
	1			0	Yes	v4.1 (Oct '21)	MR	Credit 4.1	BPDO - Material Ingredient Reporting	C	1	Use 20 products sourced from five different manufacturers that demonstrate the chemical inventory of the products	Arch / GC
			1	0	Unlikely Maybe	v4.1 (Oct '21)	MR	Credit 4.2	BPDO - Material Ingredient Optimization (Option 2)	C	1	Use products that document their material ingredient optimization for at least 25%, by cost, of the total value of permanently installed building products.	Arch / GC
2				0	Yes	v4	MR	Credit 5	Construction and Demolition Waste Management	C	2	Divert 50%, three material streams (1pt) OR 50% using Certified Commingled Recycling Facility (1 pt) - OR - 75%, four material streams (2pts), OR 75% using commingled facilities and 1 more material stream (2pts) - OR - limit C&D waste to no more than 2.5 lbs waste/sf (2pts)	GC
IEQ CATEGORY INDOOR ENVIRONMENTAL QUALITY													
Y					P		IEQ	Prereq 1	Minimum Indoor Air Quality Performance	D		For mechanically ventilated spaces: Meet minimum outdoor air intake flow requirements determined by ASHRAE 62.1-2010 ventilation rate procedure, meet sections 4 through 7 of ASHRAE 62.1-2010, and monitor outdoor air intake flows.	MEP
Y					P		IEQ	Prereq 2	Environmental Tobacco Smoke Control	D		Prohibit smoking inside building, locate exterior smoking areas at least 25 feet away from building, and post no-smoking signage within 10 ft of all building entrances. Provide entryway systems, prevent interior cross-contamination, and specify MERV 13 filters (1pt) - AND/OR - prevent exterior contamination or increase ventilation or monitor CO2 (1pt).	Owner
	2			0	Yes	v4	IEQ	Credit 1	Enhanced Indoor Air Quality Strategies	D	2		ARCH MEP
	2		1	0	Yes	v4.1 (Oct '21)	IEQ	Credit 2	Low-Emitting Materials	C	3	Achieve the threshold level of compliance with VOC emissions and content standards for 2, 3, 4 or 5 product categories 1-3 pts + exemplary.	Arch
	1			0	Yes	v4	IEQ	Credit 3	Construction Indoor Air Quality Management Plan	C	1	Develop an IAQ plan for construction and pre-occupancy phases that meets SMACNA IAQ Guidelines for Occupied Buildings Under Construction. Prohibit smoking within 25 feet of all building entrances during construction.	GC
		2		0	Likely Maybe	v4	IEQ	Credit 4	Indoor Air Quality Assessment	C	2	Perform building flush-out before OR during occupancy (1 pt) - OR - conduct IAQ testing after construction but before occupancy (2 pts)	GC MEP
	1			0	Yes	v4	IEQ	Credit 5	Thermal Comfort	D	1	Design to ASHRAE 55-2010 standards and provide thermal controls to 50% individual occupant spaces and 100% of group multi-occupant spaces	MEP
	1		1	0	Yes	v4	IEQ	Credit 6	Interior Lighting	D	2	Provide lighting controls to 90% of individual occupant spaces and 100% of group multi-occupant spaces (1 pt) - AND/OR - meet 4 of the specified criteria for lighting quality (1 pt)	Lighting
				3	Unlikely Maybe	v4.1 (Oct '21)	IEQ	Credit 7	Daylight	D	3	Provide manual or automatic glare-control devices AND Option 1: Average SDA300/50% value for regularly occupied floor area is at least 55% (2pts), 75% (3pts) - OR - Option 2: Illuminance Simulation - OR - Option 3: Illuminance Measurement	Arch
	1			0	Yes	v4	IEQ	Credit 8	Quality Views	D	1	Provide direct views to the outside that meet 2 out of 4 LEED view criteria in 75% of regularly occupied spaces.	Arch
				1	Likely Maybe	v4.1 (Oct '21)	IEQ	Credit 9	Acoustic Performance	D	1	Meet 2 criteria in all occupied spaces: HVAC background noise, sound transmission, reverberation time, meet all 3 for EP	Acoustic
ID CATEGORY INNOVATION													
	1			0	Yes	v4	ID	Credit 1	Exemplary Performance	DIC	1	TBD: many options - Digsau mentioned: Bird Deterrence, Lead Risk Reduction, Inclusive Design, Food Production, 100% LED Lighting	
	1			0	Yes	v4	ID	Credit 2	Exemplary Performance	DIC	1	See Above	
	1			0	Yes	v4	ID	Credit 3	Pilot	DIC	1	See Above	
	1			0	Yes	v4	ID	Credit 4	Innovation	DIC	1	See Above	
	1			0	Yes	v4	ID	Credit 5	Innovation	DIC	1	See Above	
	1			0	Yes	v4	ID	Credit 6	LEED Accredited Professional	DIC	1	db+ as LEED Accredited Professional on design team.	
RP CATEGORY REGIONAL PRIORITY													
			1	0	Yes	v4	RP	Credit 1	Indoor Water Use Reduction	C	1	Base credit achieved (4 pt threshold)	
			1	0	Unlikely Maybe	v4	RP	Credit 2	Building Life-Cycle Impact Reduction	C	1	Base credit may be achieved (3 pt threshold)	
	1			0	Yes	v4	RP	Credit 3	Access to Quality Transit	C	1	Base credit can be achieved (3 pt threshold)	
			1	0	Likely Maybe	v4	RP	Credit 4	Rainwater Management	C	1	Base credit may be achieved (2 pt threshold)	
						v4	RP	Credit 5	Cooling Tower	C	-	Base credit not achieved	
						v4	RP	Credit 6	High Priority Site	C	-	Base credit not achieved (2 pt threshold)	

Appendix B - Lighting Fixture Cut Sheets



Francis J. Myers Recreation Center Philadelphia, PA

Lighting Fixture Cut Sheets

100% CD
March 28, 2023

● **philadelphia**
public ledger building
600 chestnut street, suite 772
philadelphia, pa 19106
t 215 238 1644
f 215 238 1674

● **new york**
115 broadway, 5th floor
new york, ny 10006
t 646 838 4385

www.thelightingpractice.com

Project	Catalog #	Type
Prepared by	Notes	Date



Metalux

FPS LED

LED Flat Panel with Selectable Lumens and CCT

Typical Applications

• Offices • Education • Healthcare • Retail

Interactive Menu

- Order Information page 2
- Photometric Data page 3
- Product Warranty

Product Certification



Product Features



Top Product Features

- Ultra-thin approx. 2 inch height fits in shallow plenums with room to spare
- Simple switch to adjust lumens, watts and CCT on site as desired
- Switch tamper cover included
- Projected lumen maintenance based on TM21 testing standards is L87 > 60,000 hours
- 1x4, 2x2, and 2x4 sizes available, all rated for direct insulation contact (IC rated)

2' x 2'

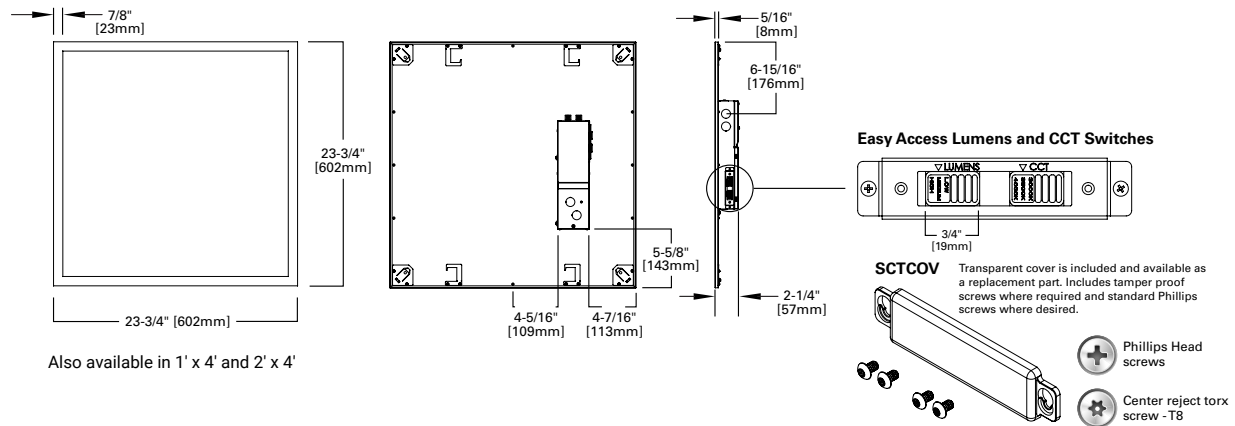

Also available in 1' x 4' and 2' x 4'

[additional product diagrams](#)



PS519329EN page 1
January 5, 2021 8:53 AM



Catalog Information:

24FPSL2SCT3-24-MED-080083889365-3500K +DF-24W-U

Date:01/27/2023
Fixture Type:

A4

Ordering Information/Performance

SKU	Size	Setting	UPC	Lumens			Power	Efficacy			Input Current (A)	
				3000K	3500K	4000K	Watts	3000K	3500K	4000K	120V	277V
14FPSL1SCT3	14	LOW	080083889440	2121	2188	2255	18.7	113.4	117	120.6	.16	.07
	14	MED		3056	3161	3258	28.2	108.4	112.1	115.5	.24	.1
	14	HI		3748	3883	4007	36.3	103.3	107	110.4	.3	.13
22FPSL2SCT3	22	LOW	080083889402	1810	1864	1909	16	113.1	116.5	119.3	.13	.06
	22	MED		2612	2694	2736	24.1	108.4	111.8	113.5	.2	.09
	22	HI		3165	3268	3349	30.4	104.1	107.5	110.1	.25	.11
24FPSL2SCT3	24	LOW	080083889365	3430	3534	3628	30.2	113.6	117	120.1	.25	.11
	24	MED		4504	4642	4795	41.5	108.5	111.9	115.5	.35	.15
	24	HI		6033	6249	6441	60.5	99.7	103.3	106.5	.5	.22

Options/Ordering Information

EL14W=EBPLED14W battery installed ⁽²⁾
 EL7W=EBPLED7W battery installed ⁽²⁾
Example catalog number=24FPSL2SCT3-EL14W

A3/8-4/18GDIM=6' 3/8" flex with dimming leads installed
Example catalog number=24FPSL2SCT3-A3/8-4/18GDIM

Notes : (2) Indicator/test switch to be installed separately. For approximate delivered lumens multiply the lumens per watt of the desired fixture by the wattage of the emergency battery pack (100 lm/W x 7=700 lumens). In Emergency mode the fixture will default to 4000K regardless of the CCT setting.

Shipping Data

Fixture Size	Pallet Size	Units per Pallet
1' x 4'	52' x 49'	48
2' x 2'	53' x 30'	44
2' x 4'	53' x 30'	22

Accessories/Ordering Information

Drywall Frame Kit

Catalog	UPC	Size
DF-24W-U	662401232970	2x4
DF-22W-U	662401232963	2x2
DF-14W-U	662401232949	1x4

Surface Mount Kit

Catalog	UPC	Size
FPXSURF24	080083867400	2x4
FPXSURF22	080083867387	2x2
FPXSURF14	080083867424	1x4

Note: Use surface kit to suspend 2x4 and 1x4.

SCTCOV

Transparent cover is included and available as a replacement part. Includes tamper proof screws where required and standard Phillips screws where desired.

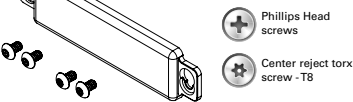

Ceiling Retention

Catalog	UPC
FPEQ	080083802685

Required by some local codes. Order one set for each fixture (Four clips per kit)

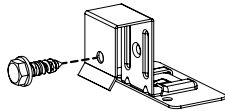

Suspension Kit

Catalog	UPC
FPSUS2	080083802784

Mounting height from ceiling
Min.=7-1/4" [184mm]
Max.=27" [286mm]

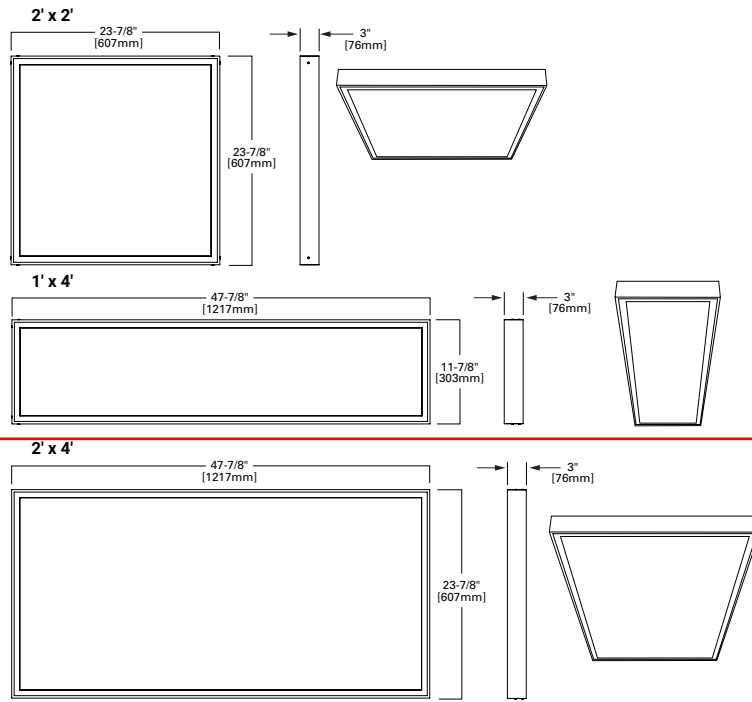

Product Specifications

Construction

- Narrow aluminum bezel is tightly held to code gauge steel back plate
- Seamless corners to maximize the light emitting surface with a refined finish

Mounting

- Integral grid clips and separate suspension clips provided for installation flexibility
- Junction box constructed of code gauge galvanized steel with an easy access hinged door
- Multiple Trade size KO provided and JBox is suitable for up to 12AWG wiring
- Topside KO for use with MWS
- Stock luminaire is less than 2 inches for use in shallow plenum or low ceiling spaces
- Surface or suspension mounting kits available. Direct suspension of 2x2 only. 2x4 and 1x4 suspend with the surface mount kit.
- Factory installed flexible cable with dimming leads options available

Controls

- Standard UNV 120-277V driver with 0-10V dimming to 10% standard
- Compatible with field installed wireless controls available for either Wavelinx or LumaWatt Pro

Electrical

- 3000K/3500K/4000K at minimum 80 CRI and three lumen options
- Projected lumen maintenance based on TM21 testing standards is L87 > 60,000 hours
- Complies with FCC Class B rating for use in residential spaces
- Emergency battery pack options available in 7W and 14W options
- Installed Flex options available

Optical Shielding

- Light guide with specialized features to optimize light extraction
- White frost lens with smooth pattern for uniform illumination
- Scratch and impact resistant lens

Compliance

- Indoor luminaires are cULus listed for 25C ambient environments
- IC rated for direct insulation contact
- RoHS compliant
- Damp location listed
- IESNA LM-79 and LM-80 standards compliant
- DesignLights Consortium qualified and classified for DLC Standard
- Meets IP5X rating from the room side with no modification needed.

Warranty

- Five-year warranty.

Photometric Data

[View IES files](#)

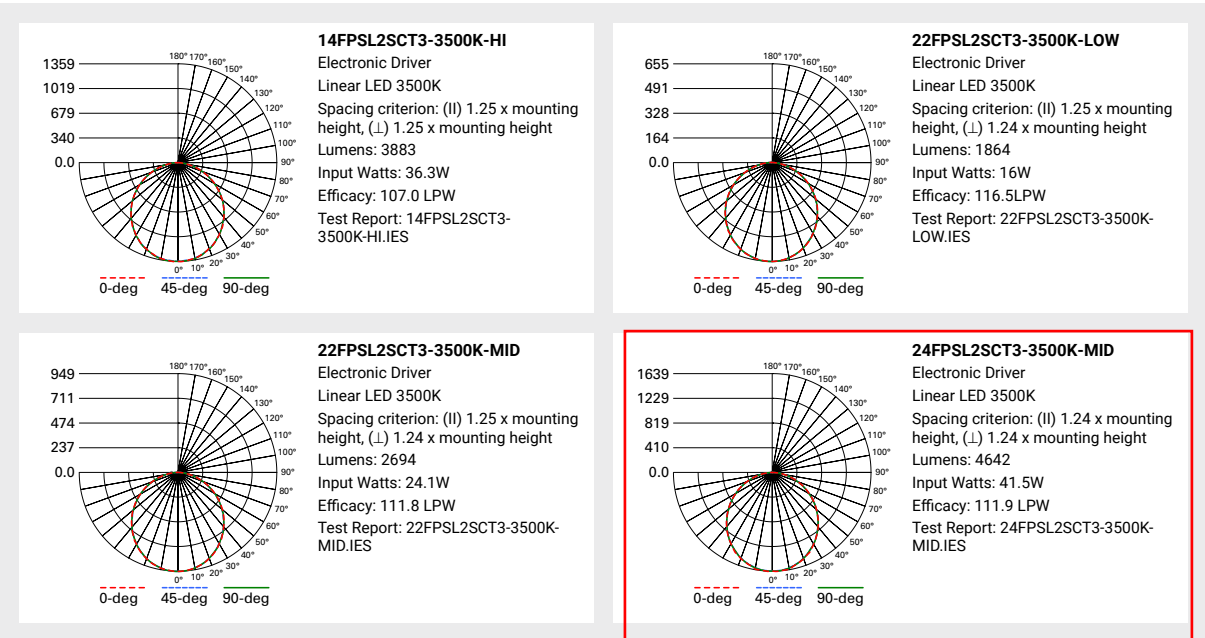

Dimensional and Mounting Details

2' x 2'

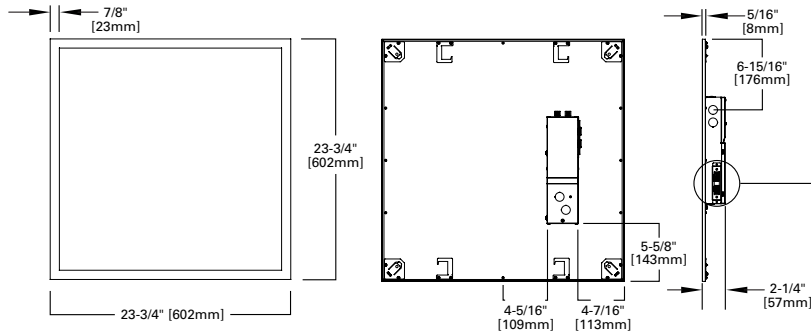

Easy Access Lumens and CCT Switches

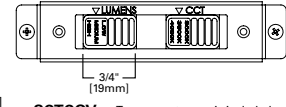

SCTCOV Transparent cover is included and available as a replacement part. Includes tamper proof screws where required and standard Phillips screws where desired.

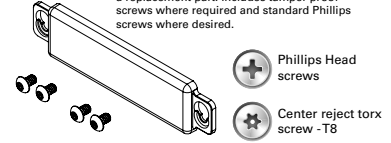

2' x 4'

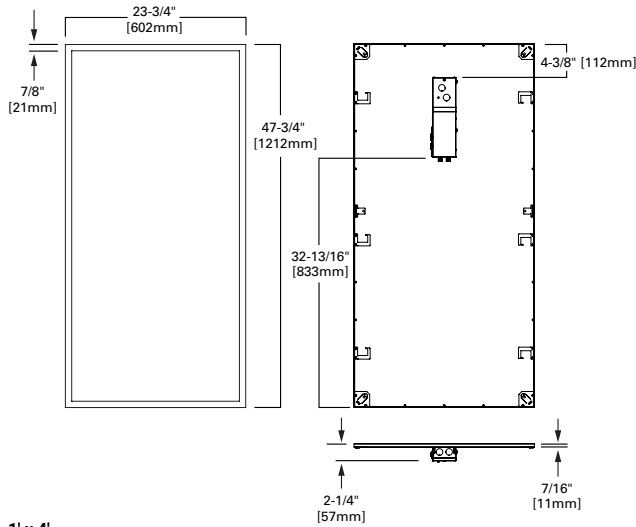

1' x 4'

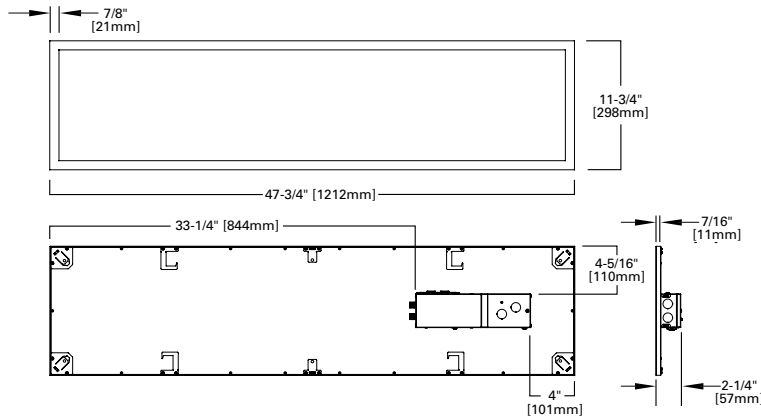

Cooper Lighting Solutions
1121 Highway 74 South
Peachtree City, GA 30269
P: 770-486-4800
www.cooperlighting.com

© 2020 Cooper Lighting Solutions
All Rights Reserved.
Specifications and dimensions
subject to change without notice.

PS519329EN page 4
January 5, 2021 8:53 AM



Catalog
Information:

24FPSL2SCT3-24-MED-080083889365-3500K +DF-24W-U

Date:01/27/2023
Fixture Type:

A4

Project		Catalog #		Type	
Prepared by		Notes		Date	



Metalux

FPS LED

LED Flat Panel with Selectable Lumens and CCT

Typical Applications

• Offices • Education • Healthcare • Retail

Interactive Menu

- Order Information page 2
- Photometric Data page 3
- Product Warranty

Product Certification



Product Features



Top Product Features

- Ultra-thin approx. 2 inch height fits in shallow plenums with room to spare
- Simple switch to adjust lumens, watts and CCT on site as desired
- Switch tamper cover included
- Projected lumen maintenance based on TM21 testing standards is L87 > 60,000 hours
- 1x4, 2x2, and 2x4 sizes available, all rated for direct insulation contact (IC rated)

2' x 2'

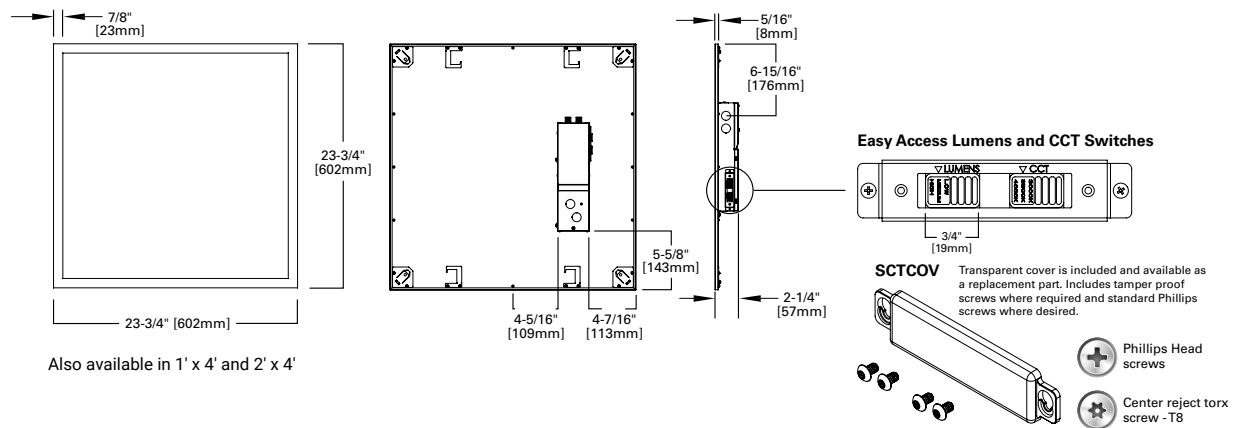

Also available in 1' x 4' and 2' x 4'

[additional product diagrams](#)



PS519329EN page 1
January 5, 2021 8:53 AM



Catalog Information: 24FPSL2SCT3-24-MED-080083889365-3500K +DF-24W-U + EL14W

Date:01/27/2023
Fixture Type:

A4-EM

Ordering Information/Performance

SKU	Size	Setting	UPC	Lumens			Power	Efficacy			Input Current (A)	
				3000K	3500K	4000K	Watts	3000K	3500K	4000K	120V	277V
14FPSL1SCT3	14	LOW	080083889440	2121	2188	2255	18.7	113.4	117	120.6	.16	.07
	14	MED		3056	3161	3258	28.2	108.4	112.1	115.5	.24	.1
	14	HI		3748	3883	4007	36.3	103.3	107	110.4	.3	.13
22FPSL2SCT3	22	LOW	080083889402	1810	1864	1909	16	113.1	116.5	119.3	.13	.06
	22	MED		2612	2694	2736	24.1	108.4	111.8	113.5	.2	.09
	22	HI		3165	3268	3349	30.4	104.1	107.5	110.1	.25	.11
24FPSL2SCT3	24	LOW	080083889365	3430	3534	3628	30.2	113.6	117	120.1	.25	.11
	24	MED		4504	4642	4795	41.5	108.5	111.9	115.5	.35	.15
	24	HI		6033	6249	6441	60.5	99.7	103.3	106.5	.5	.22

Options/Ordering Information

EL14W=EBPLED14W battery installed (2)

EL7W=EBPLED7W battery installed (2)

Example catalog number=24FPSL2SCT3-EL14W

A3/8-4/18GDIM=6' 3/8" flex with dimming leads installed

Example catalog number=24FPSL2SCT3-A3/8-4/18GDIM

Notes : (2) Indicator/test switch to be installed separately. For approximate delivered lumens multiply the lumens per watt of the desired fixture by the wattage of the emergency battery pack (100 lm/W x 7=700 lumens). In Emergency mode the fixture will default to 4000K regardless of the CCT setting.

Shipping Data

Fixture Size	Pallet Size	Units per Pallet
1' x 4'	52' x 49'	48
2' x 2'	53' x 30'	44
2' x 4'	53' x 30'	22

Accessories/Ordering Information

Drywall Frame Kit

Catalog	UPC	Size
DF-24W-U	662401232970	2x4
DF-22W-U	662401232963	2x2
DF-14W-U	662401232949	1x4

Surface Mount Kit

Catalog	UPC	Size
FPXSURF24	080083867400	2x4
FPXSURF22	080083867387	2x2
FPXSURF14	080083867424	1x4

Note: Use surface kit to suspend 2x4 and 1x4.

SCTCOV

Transparent cover is included and available as a replacement part. Includes tamper proof screws where required and standard Phillips screws where desired.

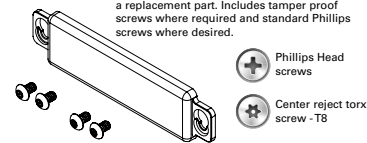

Ceiling Retention

Catalog	UPC
FPEQ	080083802685

Required by some local codes. Order one set for each fixture (Four clips per kit)

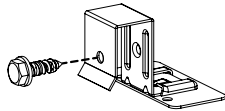

Suspension Kit

Catalog	UPC
FPSUS2	080083802784

Mounting height from ceiling
Min. = 7-1/4" [184mm]
Max. = 27" [286mm]

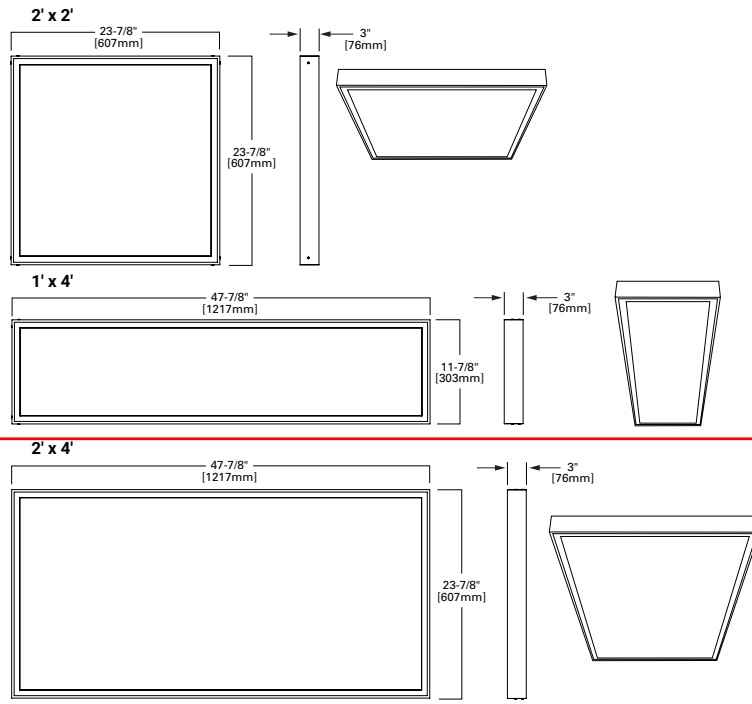

Product Specifications

Construction

- Narrow aluminum bezel is tightly held to code gauge steel back plate
- Seamless corners to maximize the light emitting surface with a refined finish

Mounting

- Integral grid clips and separate suspension clips provided for installation flexibility
- Junction box constructed of code gauge galvanized steel with an easy access hinged door
- Multiple Trade size KO provided and JBox is suitable for up to 12AWG wiring
- Topside KO for use with MWS
- Stock luminaire is less than 2 inches for use in shallow plenum or low ceiling spaces
- Surface or suspension mounting kits available. Direct suspension of 2x2 only. 2x4 and 1x4 suspend with the surface mount kit.
- Factory installed flexible cable with dimming leads options available

Controls

- Standard UNV 120-277V driver with 0-10V dimming to 10% standard
- Compatible with field installed wireless controls available for either Wavelinx or LumaWatt Pro

Electrical

- 3000K/3500K/4000K at minimum 80 CRI and three lumen options
- Projected lumen maintenance based on TM21 testing standards is L87 > 60,000 hours
- Complies with FCC Class B rating for use in residential spaces
- Emergency battery pack options available in 7W and 14W options
- Installed Flex options available

Optical Shielding

- Light guide with specialized features to optimize light extraction
- White frost lens with smooth pattern for uniform illumination
- Scratch and impact resistant lens

Compliance

- Indoor luminaires are cULus listed for 25C ambient environments
- IC rated for direct insulation contact
- RoHS compliant
- Damp location listed
- IESNA LM-79 and LM-80 standards compliant
- DesignLights Consortium qualified and classified for DLC Standard
- Meets IP5X rating from the room side with no modification needed.

Warranty

- Five-year warranty.

Photometric Data

[View IES files](#)

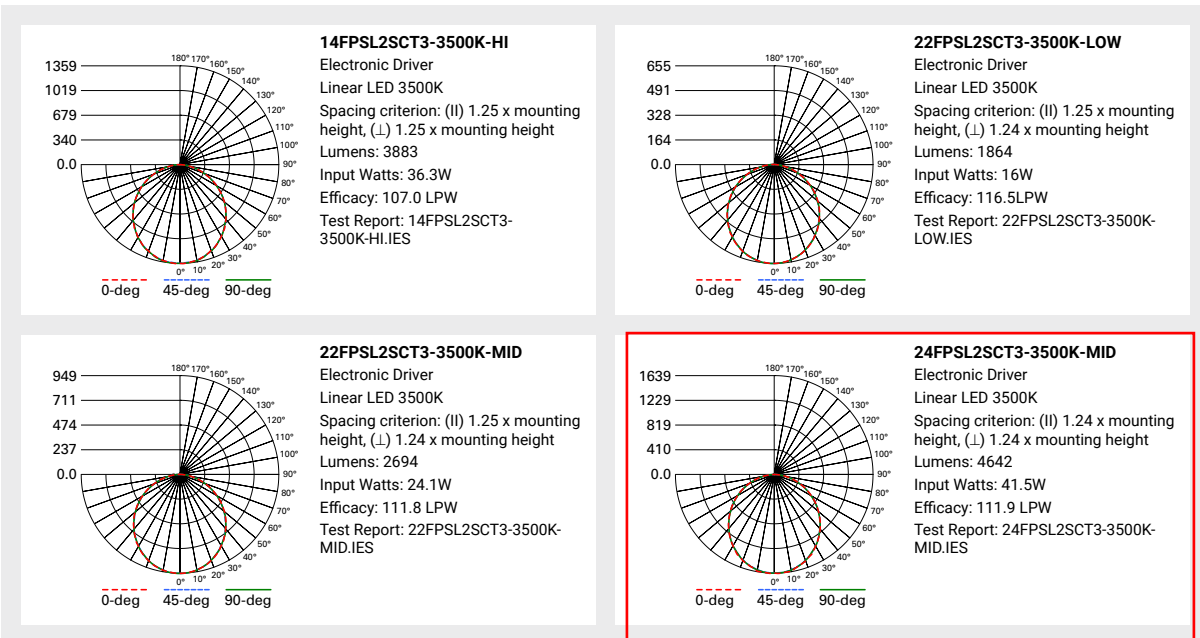

Dimensional and Mounting Details

2' x 2'

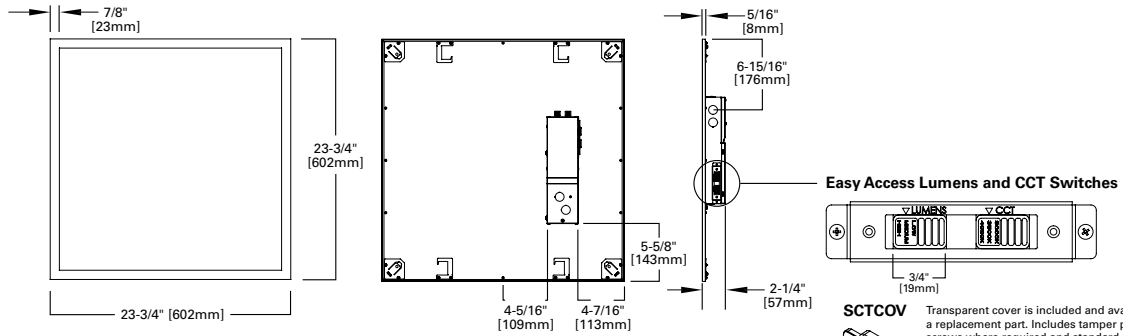

2' x 4'

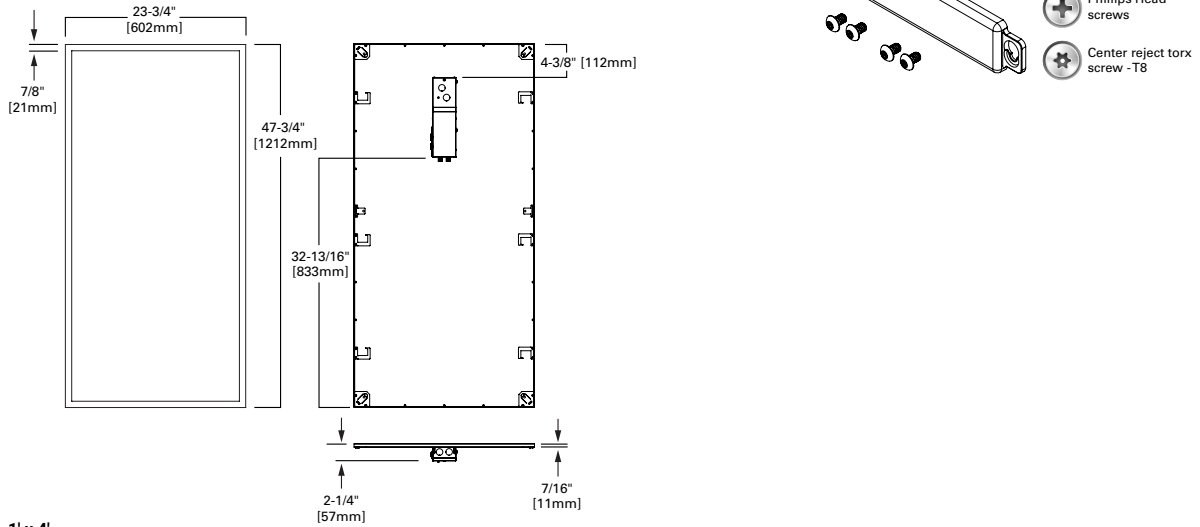

1' x 4'

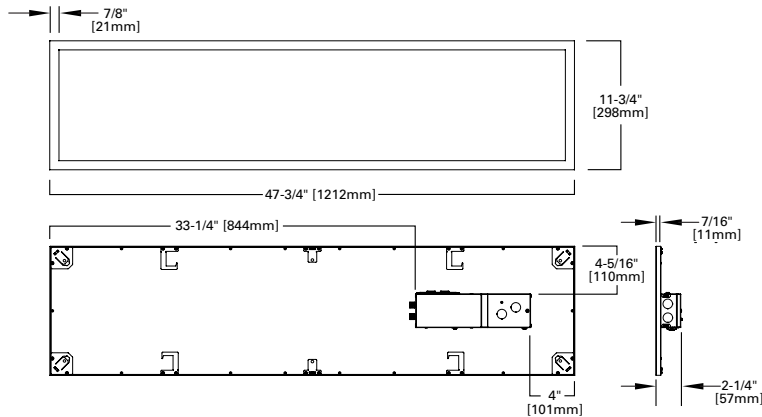

Cooper Lighting Solutions
1121 Highway 74 South
Peachtree City, GA 30269
P: 770-486-4800
www.cooperlighting.com

© 2020 Cooper Lighting Solutions
All Rights Reserved.
Specifications and dimensions
subject to change without notice.

PS519329EN page 4
January 5, 2021 8:53 AM



Catalog Information: 24FPSL2SCT3-24-MED-080083889365-3500K +DF-24W-U + EL14W

Date:01/27/2023
Fixture Type:

A4-EM

Slot 4 LED
Recessed Linear

Type:

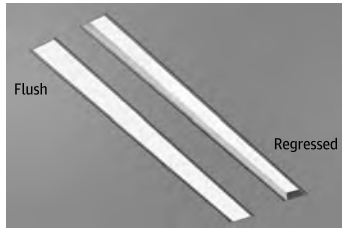

Slot 4 LED takes both form and function a step further with increased efficacy and integral controls creating a digitally addressable luminaire that is perfect where visually harmonious illumination and energy efficiency are desired.

Slot 4 LED is the ideal choice for spaces that emphasize lines and clean contemporary design. It is a perfect fit for Armstrong TechZone™ ceiling systems. A regressed lens option provides added dimension to the sleek, slender design and the flush lens now has a Wet Label option.

Project:

Catalog Number:
DO NOT TYPE HERE. Autopopulated field.

Specification Features

Housing

Nominal 4" x 2", 3", 4", 5", 6", 7", 8' and continuous rows in 1" increments as standard, upper housing fabricated from cold-rolled steel with extruded aluminum ceiling trim.

Finish

Polyester powder coat painted finish.

Reflector

Precision-formed steel; high reflectance matte white powder coat; 93% reflectivity.

Shielding

Flush Lens: Snap-in 90% transmissive satin acrylic lens.

Regressed Lens: Lay-in 90% transmissive satin acrylic lens.

Mounting

Recessed. Available for sheetrock, 9/16" slot grid or 15/16" inverted tee ceilings, or 9/16" inverted tee.

Certification

CSA tested to UL 1598 standards. Optional Damp or Wet location listings available, see ordering tree. This product is IC rated.

Warranty

5-year limited warranty. This is the only warranty provided and no other statements in this specification sheet create any warranty of any kind. All other express and implied warranties are disclaimed. Complete warranty terms located at: www.acuitybrands.com/support/warranty/terms-and-conditions

Note: Actual performance may differ as a result of end-user environment and application. All values are design or typical values, measured under laboratory conditions at 25 °C. Specifications subject to change without notice.

Technical Drawing

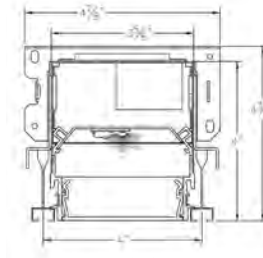

Flush - (FLP)



Fixture Performance - SL4L*

Lumens Output	400 LMF		600 LMF**		800 LMF**		1000LMF	
	RLP	FLP	RLP	FLP	RLP	FLP	RLP	FLP
Delivered Lumens/FT	316	314	544	541	737	734	928	924
Input Watts/FT	4	4	6	6	8	8	10	10
Lumen/Watt	91	91	95	95	93	93	90	89

* CCT (35K)

* Consult factory for customized lumen output and wattage

** Based on calculated values

Note: UGR data available on Page 5

LED Components

Linear: Nichia® - 757 Series LED chips (available in 80 or 90 CRI)

LED Life

Rated 65,000 hours (L80) at 25 °C ambient temperature.

Color Consistency

The Acuity Brands circuit boards for the linear LED components use a precise binning algorithm which creates a consistent color temperature from board to board. Color variation is no greater than a 2.5 Step MacAdam (2.5SDCM) along the black body locus from board to board.

Driver

eldoLED constant current driver options delivers ultra-smooth dimming resolution from 100% to 0.1%, while assuring flicker free, low current inrush, 89% efficiency and low EMI.

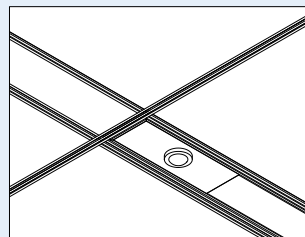

Occupancy Sensor (PDT) and/or Photocell (ADC)

Integrated Controls

Optional nLight® embedded controls make luminaire addressable- allowing it to digitally communicate with other nLight enabled controls such as dimmers, switches, occupancy sensors and photocontrols. Simply connect all the nLight enabled control devices using standard CAT5 Cabling. (Input option: NLIGHT)

Photometry

For photometric information refer to www.marklighting.com.

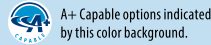

Ordering

Example: SL4L LOP 4FT FLP TG 90CRI 35K 400LMF MIN1 277V NLIGHT

Series	Linear Length Plan	Total Run Length		Fixture Style	Ceiling Trim	Direct Light Source Color Rendering	Direct LED Color Temp
SL4L Slot 4 LED Linear Recessed	LOP Linear Optimized Plan	2FT 2' 3FT 3' 4FT 4' 5FT 5' 6FT 6'	7FT 7' 8FT 8' _FT_ *Specify continuous linear feet in 1" increments (7FT6 = 7FT 6IN)	RLP ¹³ Regressed Lens FLP ² Flush Lens	FL ⁴ 5/8" Flange(sheetrock) TG 9/16" or 15/16" Flat or Inverted Tee GB ⁴ Trimless (sheetrock) WFL Perimeter Mount, 5/8" Flange (Sheetrock) WTG 9/16" Flat or Inverted Tee, Perimeter Mount <small>*For metal pan, hard wood or other ceiling types consult factory.</small>	80CRI 80 CRI 90CRI 90 CRI	27K* 2700K 30K 3000K 35K 3500K 40K 4000K 50K* 5000K

Direct LED Light Output	Direct Distribution	Downlight¹¹	Downlight Color Rendering	Downlight Color Temp	Minimum Dimming Level	Voltage
400LMF 400 Lumens per FT 600LMF 600 Lumens per FT 800LMF 800 Lumens per FT 1000LMF 1000 Lumens per FT _LMF* ¹¹ ## Lumens per FT (Limited to 300LMF to 1000LMF in 50LMF increments)	(blank) Standard Distribution WW ⁵ Wall Wash	ZDL ¹⁶ LED Downlight Standard _DL ¹⁶ LED downlights per Run (3DL, 4DL, ect.)	S80CRI 80 CRI S90CRI 90 CRI	S27K 2700K S30K 3000K S35K 3500K S40K 4000K	NODIM Non - Dim MIN1 Constant current, dimming to 1% DARK Constant current, dimming to 0.1% MINS ⁷ Constant current, dimming to 5% MIN10 ¹⁸ Constant current, dimming to 10%	120 120V 277 277V 347 ⁸ 347V

Finish	Emergency Options	Control Input	Primary Sensor¹³	Secondary Sensor¹³
(blank) White (satin) xxx/BLKT Black (satin) xxx/SLVT Silver (satin) xxx/RALTB RAL paint finish <small>xxx = fill in with the appropriate ceiling trim. Only trims are painted RALTB is for pricing only. Replace with applicable RAL number and texture when placing order</small>	(blank) No Emergency _E10WLCP ⁹ Number of 4ft Emergency Section(s) with battery pack _EC ¹⁰ # of Emergency Circuits	(blank) Non-dim ¹² ZT 0 10V NLIGHT nLight enabled NLTAIR2 ¹⁹ nLight Air (wireless enabled) ECOD ¹⁷ Lutron Hi-Lume digital driver ECOD2 ^{16,17} Lutron Hi-Lume 2-wire (1% dimming) ECOD5 ⁷ Lutron 5-series digital driver (5% dimming) DALI ²⁰ DALI compatible	(blank) Single Zone, No Sensor NS Multi-zone, No Sensor Main Zone PDT ¹⁴ Dual Technology Occupancy Sensor, PIR and Microphonics Sensor ADC ¹⁴ Daylight Dimming Sensor API ¹⁵ Passive Infrared Occupancy Sensor and Daylight Dimming Sensor APD ¹⁵ Dual Technology Occupancy Sensor and Daylight Dimming Sensor	(blank) No additional zones/sensors SNS Multi-zone, with no sensor in secondary zone SPDT ¹⁴ Dual Technology Occupancy Sensor, PIR and Microphonics Sensor SADC ¹⁴ Dual Technology Occupancy Sensor, PIR and Microphonics Sensor SAPI ¹⁵ Passive Infrared Occupancy Sensor and Daylight Dimming Sensor SAPD ¹⁵ Dual Technology Occupancy Sensor and Daylight Dimming Sensor

Tertiary Zone	Options
(blank) No additional zones/sensors TNS Multi-zone, with no sensor in tertiary zone	(blank) No Options CP ²¹ Chicago Plenum BAA Buy America(n) Compliant WL ¹¹ Wet Location Listing DPL Damp Location Listing PWS 6" Pre-Wire, 3/8" Diameter, 18 Gauge

* Requires longer lead time.

Notes

- Supplied with lift and shift lay-in lens.
- Supplied with snap-in lens.
- Wet Location label not available with downlights, regressed lens, or with sensor options, or PWS. Cannot be installed on vertical surfaces.
- Not intended for post sheetrock installation.
- Wall Wash not available with downlights, RLP lens and all sensor options.
- See notes on page 3, downlights only available with DARK dimming level.
- MINS requires ECOD5 control input. ECOD5 only available with MINS dimming.
- Not available with 2' sections, E10WLCP or sensors. Only available with NODIM or MIN1 with ZT.
- Default battery pack is integral, battery pack will be remote on 2' & 3' (RE10WLCP). Integral battery not available with RLP, WW, sensors or downlights. Only 1 integral battery pack per unit. CP listing must have an integral battery. Remote batteries are not wet location listed, they may be used with a wet location fixture if the battery itself is mounted in a dry location.
- Standard 4" EC section, defaults to end of run. 2ft, 3ft and 5ft powers entire fixture, 6ft powers 3ft EC section.
- Not available with ECOD, ECOD2, ECOD5.
- Only available with NODIM option.
- Sensors not available with WW, NODIM driver, WL, RLP, downlights or 2' & 3' units. Not available with 347 & NLIGHT together. Default location for sensor is the left side of the fixture. For runs the first fixture will include the sensor.
- Requires ZT or NLIGHT Control Input.
- Requires ZT, NLIGHT or NLTAIR2 Control Input.
- Must use 120 volt.
- Must select MIN1 options.
- MIN10 not available with 347, sensors, NLIGHT or NLTAIR2, requires ZT.
- Must select MIN1 or DARK. Not available with RLP, WW, PDT, ADC or 347, DPL or WL.
- DALI is only available with DARK or MIN1. It is not available with sensors or downlights.
- CP not available with NLTAIR2.

A+ Capable Luminaire

This item is an A+ capable luminaire, which has been designed and tested to provide consistent color appearance and out-of-the-box control compatibility with simple commissioning.

- All configurations of this luminaire meet the Acuity Brands' specification for chromatic consistency
- This luminaire is part of an A+ Certified solution for nLight® control networks when ordered with drivers marked by a shaded background*
- This luminaire is part of an A+ Certified solution for nLight control networks, providing advanced control functionality at the luminaire level, when selection includes driver and control options marked by a shaded background*

To learn more about A+, visit www.acuitybrands.com/aplus.

*See ordering tree for details



Technical Drawing

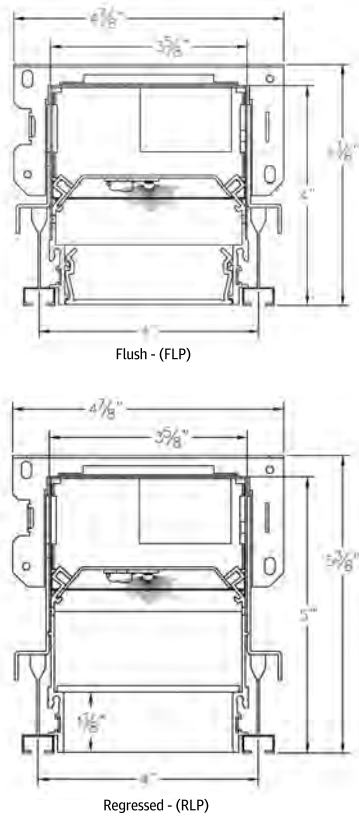

Ceiling Trim

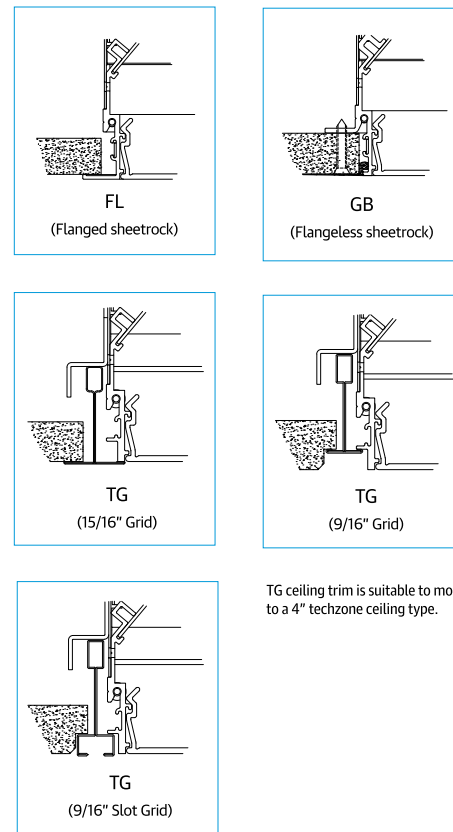

TG ceiling trim is suitable to mounted to a 4" techzone ceiling type.

Emergency Battery

Internally Mounted (E10WLCP)

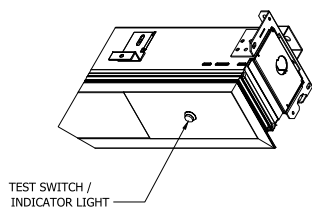

Notes

- Delivers 700 lumens per 4FT length. Default location is the right side of fixture and end of run.
- Provided with 4FT of flexible conduit. Maximum of 25FT remote distance if extended. Extension provided by others.
- See ordering tree notes for remote battery pack scenarios.

Remote Mounted (RE10WLCP)

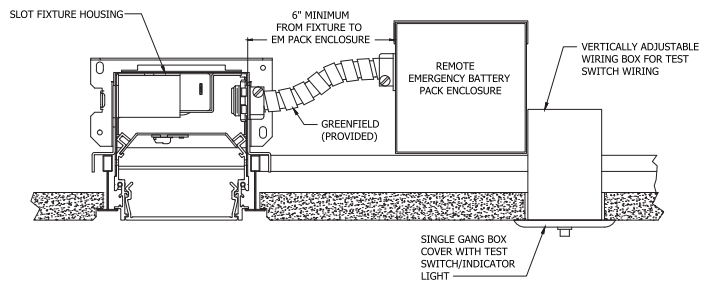

nLight Air Wireless

nLight Air

The default location of the antenna will be at the left end of an individual unit. On a run, it will be placed at the beginning or left end of the first section. Please consult factory for other placement options.

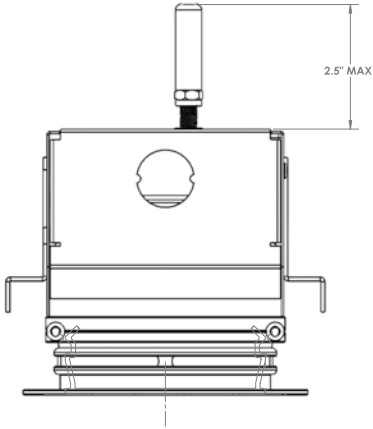

Downlights

Optional downlights powered by Xicato Spot Modules are available with any linear length and no less than 2' on center spacing. Each downlight module is 6W with 700 lumens delivered (28 degree beam spread). Downlights are supplied with a dedicated feed-point and will be controlled separately.

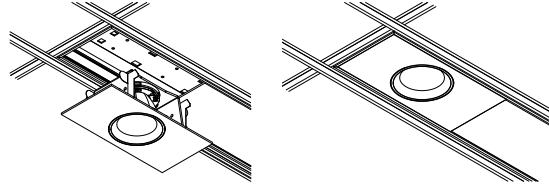

Standard Downlight Location

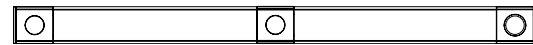

Other Downlight Configuration (consult factory)

Notes

- 2DL - Downlights are supplied at each end of an individual unit
- _DL - Multiple downlights will be supplied with one at each end and the remainder will be centered over the length of the run.
- Downlights are not adjustable and are provided with solite lens

Continuous Runs

Slot 4 LED continuous rows can be configured in 1" increments.

Run Patterns, Corners and Junction

Slot 4 LED patterns be configured in 1' increments with illuminated 90° inside and outside corners, T junctions, and X junctions with standard 2' corner and junction lengths. For custom angles, corner or junction lengths, consult factory.

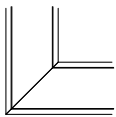

90° Corner

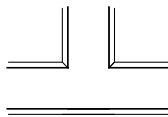

T Junction

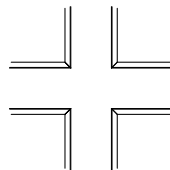

X Junction

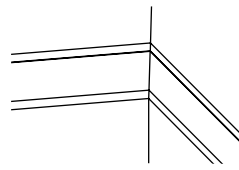

Inside Corner

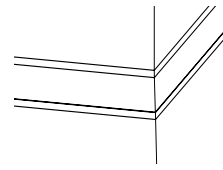

Outside Corner

Layout Sketch

Please draw and configure your linear run below.

OPTICS

Slot LED's patent-pending, precision lumen DIRECTIR optics condition and refract light to deliver accurately controlled, striation-free, and uniform white light. All lumen DIRECTIR optics are injection-molded, optical grade, UV-resistant acrylic with selective finishing/polishing treatment.

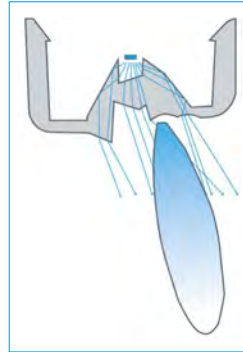
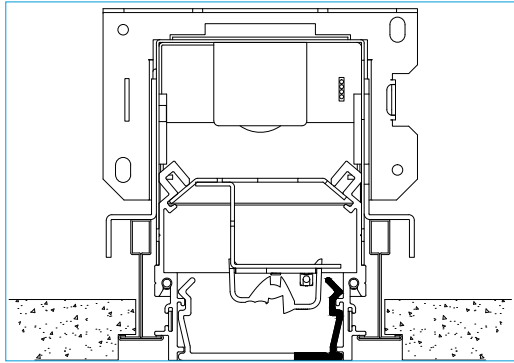

Wall Wash (WW)

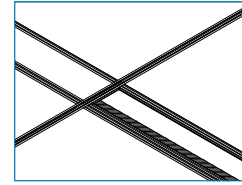

INTEGRATED SENSOR LAYOUT

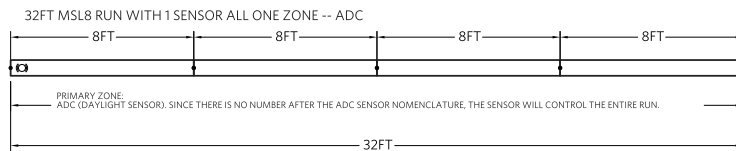

Notes:
• Only one sensor per zone

OCCUPANCY DETECTION COVERAGE

At the 7.5 ft (2.9 m) hanging height of a typical pendant mount fixture the sensor provides 10 ft (3.05 m) radial detection of small motion. At a 9 ft (2.74 m) hanging height the radius is 12 ft (3.66 m) for small motion.

Adequate for walking motion detection from mounting heights between 7.5 ft (2.29 m) and 20 ft (6.10 m).

Initial detection will occur earlier when walking across sensor's field of view than when walking directly at sensor.

Initial detection of walking motion into long coverage segment will occur at distances of 2x the mounting height up to 15 ft (4.57 m) and 1.75x up to 20 ft (6.10 m). Lens assembly rotates 15° to enable adjustment in order to line up long segments.

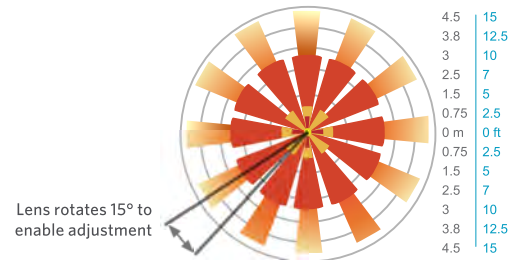

UGR CHART

Lumen Package	UGR (70% 50% 20% REFLECTANCE USING A 4H X 8H ROOM SIZE)					
	Crosswise			Endwise		
	FLP	RLP	WW	FLP	RLP	WW
400LMF	21.4	20.8	20.2	21.4	17.8	18.7
600LMF	23.3	22.7	22.1	23.3	19.7	20.6
800LMF	24.4	23.7	23.2	24.3	20.8	21.6
1000LMF	25.2	24.5	24	25.1	21.6	22.4

*UGR varies based on luminaire options and is affected by application dependent parameters. Numbers depicted here are considered "Luminaire-UGR" and/or "Point-UGR" values. To determine a more precise maximum UGR value ("Application-UGR"), a full lighting design layout should be completed with the selected luminaire configuration for each application.

MARK ARCHITECTURAL LIGHTING™

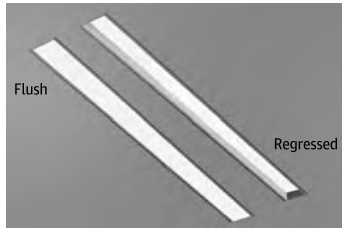

Slot 4 LED Recessed Linear

Slot 4 LED takes both form and function a step further with increased efficacy and integral controls creating a digitally addressable luminaire that is perfect where visually harmonious illumination and energy efficiency are desired.

Slot 4 LED is the ideal choice for spaces that emphasize lines and clean contemporary design. It is a perfect fit for Armstrong TechZone™ ceiling systems. A regressed lens option provides added dimension to the sleek, slender design and the flush lens now has a Wet Label option.

Type:

Project:

Catalog Number:

DO NOT TYPE HERE. Autopopulated field.

Specification Features

Housing

Nominal 4" x 2", 3", 4", 5", 6", 7", 8" and continuous rows in 1" increments as standard, upper housing fabricated from cold-rolled steel with extruded aluminum ceiling trim.

Finish

Polyester powder coat painted finish.

Reflector

Precision-formed steel; high reflectance matte white powder coat; 93% reflectivity.

Shielding

Flush Lens: Snap-in 90% transmissive satin acrylic lens.

Regressed Lens: Lay-in 90% transmissive satin acrylic lens.

Mounting

Recessed. Available for sheetrock, 9/16" slot grid or 15/16" inverted tee ceilings, or 9/16" inverted tee.

Certification

CSA tested to UL 1598 standards. Optional Damp or Wet location listings available, see ordering tree. This product is IC rated.

Warranty

5-year limited warranty. This is the only warranty provided and no other statements in this specification sheet create any warranty of any kind. All other express and implied warranties are disclaimed. Complete warranty terms located at: www.acuitybrands.com/support/warranty/terms-and-conditions

Note: Actual performance may differ as a result of end-user environment and application. All values are design or typical values, measured under laboratory conditions at 25 °C. Specifications subject to change without notice.

Technical Drawing

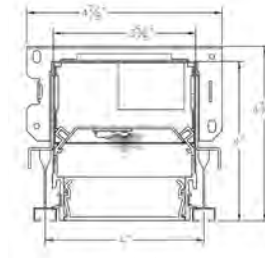

Flush - (FLP)



Declare.

Fixture Performance - SL4L*

Lumens Output	400 LMF		600 LMF**		800 LMF**		1000LMF	
	RLP	FLP	RLP	FLP	RLP	FLP	RLP	FLP
Delivered Lumens/FT	316	314	544	541	737	734	928	924
Input Watts/FT	4	4	6	6	8	8	10	10
Lumen/Watt	91	91	95	95	93	93	90	89

* CCT (35K)

* Consult factory for customized lumen output and wattage

** Based on calculated values

Note: UGR data available on Page 5

LED Components

Linear: Nichia® - 757 Series LED chips (available in 80 or 90 CRI)

LED Life

Rated 65,000 hours (L80) at 25 °C ambient temperature.

Color Consistency

The Acuity Brands circuit boards for the linear LED components use a precise binning algorithm which creates a consistent color temperature from board to board. Color variation is no greater than a 2.5 Step MacAdam (2.5SDCM) along the black body locus from board to board.

Driver

eldoLED constant current driver options delivers ultra-smooth dimming resolution from 100% to 0.1%, while assuring flicker free, low current inrush, 89% efficiency and low EMI.

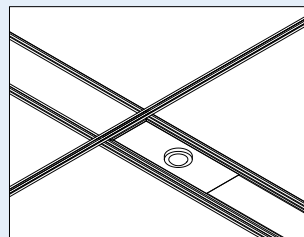

Occupancy Sensor (PDT) and/or Photocell (ADC)

Integrated Controls

Optional nLight® embedded controls make luminaire addressable- allowing it to digitally communicate with other nLight enabled controls such as dimmers, switches, occupancy sensors and photocontrols. Simply connect all the nLight enabled control devices using standard CAT5 Cabling. (Input option: NLIGHT)

Photometry

For photometric information refer to www.marklighting.com.

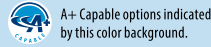

Ordering

Example: SL4L LOP 4FT FLP TG 90CRI 35K 400LMF MIN1 277V NLIGHT

Series	Linear Length Plan	Total Run Length		Fixture Style	Ceiling Trim	Direct Light Source Color Rendering	Direct LED Color Temp
SL4L Slot 4 LED Linear Recessed	LOP Linear Optimized Plan	2FT 2' 3FT 3' 4FT 4' 5FT 5' 6FT 6'	7FT 7' 8FT 8' _FT_ *Specify continuous linear feet in 1" increments (7FT6 = 7FT 6IN)	RLP ^{9,3} Regressed Lens FLP ² Flush Lens	FL ⁴ 5/8" Flange(sheetrock) TG 9/16" or 15/16" Flat or Inverted Tee GB ⁴ Trimless (sheetrock) WFL Perimeter Mount, 5/8" Flange (Sheetrock) WTG 9/16" Flat or Inverted Tee, Perimeter Mount <small>*For metal pan, hard wood or other ceiling types consult factory.</small>	80CRI 80 CRI 90CRI 90 CRI	27K* 2700K 30K 3000K 35K 3500K 40K 4000K 50K* 5000K

Direct LED Light Output	Direct Distribution	Downlight¹¹	Downlight Color Rendering	Downlight Color Temp	Minimum Dimming Level	Voltage
400LMF 400 Lumens per FT 600LMF 600 Lumens per FT 800LMF 800 Lumens per FT 1000LMF 1000 Lumens per FT _LMF* ¹³ ## Lumens per FT (Limited to 300LMF to 1000LMF in 50LMF increments)	(blank) Standard Distribution WW ⁵ Wall Wash	ZDL ^{13,6} LED Downlight Standard _DL ^{13,6} LED downlights per Run (3DL, 4DL, ect.)	S80CRI 80 CRI S90CRI 90 CRI	S27K 2700K S30K 3000K S35K 3500K S40K 4000K	NODIM Non - Dim MIN1 Constant current, dimming to 1% DARK Constant current, dimming to 0.1% MINS ⁷ Constant current, dimming to 5% MIN10 ¹⁸ Constant current, dimming to 10%	120 120V 277 277V 347 ⁸ 347V

Finish	Emergency Options	Control Input	Primary Sensor¹³	Secondary Sensor¹³
(blank) White (satin) xxx/BLKT Black (satin) xxx/SLVT Silver (satin) xxx/RALTB RAL paint finish <small>xxx = fill in with the appropriate ceiling trim. Only trims are painted RALTB is for pricing only. Replace with applicable RAL number and texture when placing order</small>	(blank) No Emergency _E10WLCP ⁹ Number of 4ft Emergency Section(s) with battery pack _EC ¹⁰ # of Emergency Circuits	(blank) Non-dim ¹² ZT 0 10V NLIGHT nLight enabled NLTAIR2 ¹⁹ nLight Air (wireless enabled) ECOD ^{8,17} Lutron Hi-Lume digital driver ECOD2 ^{8,16,17} Lutron Hi-Lume 2-wire (1% dimming) ECOD5 ^{8,7} Lutron 5-series digital driver (5% dimming) DALI ²⁰ DALI compatible	(blank) Single Zone, No Sensor NS Multi-zone, No Sensor Main Zone PDT ¹⁴ Dual Technology Occupancy Sensor, PIR and Microphonics Sensor ADC ¹⁴ Daylight Dimming Sensor API ¹⁵ Passive Infrared Occupancy Sensor and Daylight Dimming Sensor APD ¹⁵ Dual Technology Occupancy Sensor and Daylight Dimming Sensor	(blank) No additional zones/sensors SNS Multi-zone, with no sensor in secondary zone SPDT ¹⁴ Dual Technology Occupancy Sensor, PIR and Microphonics Sensor SADC ¹⁴ Dual Technology Occupancy Sensor, PIR and Microphonics Sensor SAPI ¹⁵ Passive Infrared Occupancy Sensor and Daylight Dimming Sensor SAPD ¹⁵ Dual Technology Occupancy Sensor and Daylight Dimming Sensor

Tertiary Zone	Options
(blank) No additional zones/sensors TNS Multi-zone, with no sensor in tertiary zone	(blank) No Options CP ²¹ Chicago Plenum BAA Buy America(n) Compliant WL ^{13,11} Wet Location Listing DPL Damp Location Listing PWS 6" Pre-Wire, 3/8" Diameter, 18 Gauge

* Requires longer lead time.

Notes

- Supplied with lift and shift lay-in lens.
- Supplied with snap-in lens.
- Wet Location label not available with downlights, regressed lens, or with sensor options, or PWS. Cannot be installed on vertical surfaces.
- Not intended for post sheetrock installation.
- Wall Wash not available with downlights, RLP lens and all sensor options.
- See notes on page 3, downlights only available with DARK dimming level.
- MINS requires ECOD5 Control Input. ECOD5 only available with MINS dimming.
- Not available with 2' sections, E10WLCP or sensors. Only available with NODIM or MIN1 with ZT.
- Default battery pack is integral, battery pack will be remote on 2' & 3' (RE10WLCP). Integral battery not available with RLP, WW, sensors or downlights. Only 1 integral battery pack per unit. CP listing must have an integral battery. Remote batteries are not wet location listed, they may be used with a wet location fixture if the battery itself is mounted in a dry location.
- Standard 4" EC section, defaults to end of run. 2ft, 3ft and 5ft powers entire fixture, 6ft powers 3ft EC section.
- Not available with ECOD, ECOD2, ECOD5.
- Only available with NODIM option.
- Sensors not available with WW, NODIM driver, WL, RLP, downlights or 2' & 3' units. Not available with 347 & NLIGHT together. Default location for sensor is the left side of the fixture. For runs the first fixture will include the sensor.
- Requires ZT or NLIGHT Control Input.
- Requires ZT, NLIGHT or NLTAIR2 Control Input.
- Must use 120 volt.
- Must select MIN1 options.
- MIN10 not available with 347, sensors, NLIGHT or NLTAIR2, requires ZT.
- Must select MIN1 or DARK. Not available with RLP, WW, PDT, ADC or 347, DPL or WL.
- DALI is only available with DARK or MIN1. It is not available with sensors or downlights.
- CP not available with NLTAIR2.

A+ Capable Luminaire

This item is an A+ capable luminaire, which has been designed and tested to provide consistent color appearance and out-of-the-box control compatibility with simple commissioning.

- All configurations of this luminaire meet the Acuity Brands' specification for chromatic consistency
- This luminaire is part of an A+ Certified solution for nLight® control networks when ordered with drivers marked by a shaded background*
- This luminaire is part of an A+ Certified solution for nLight control networks, providing advanced control functionality at the luminaire level, when selection includes driver and control options marked by a shaded background*

To learn more about A+, visit www.acuitybrands.com/aplus.

*See ordering tree for details



Technical Drawing

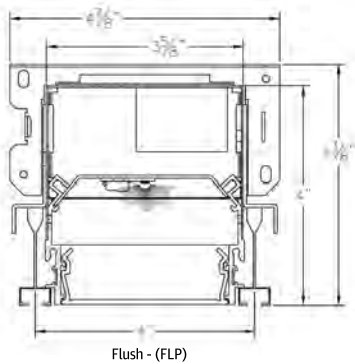

Flush - (FLP)

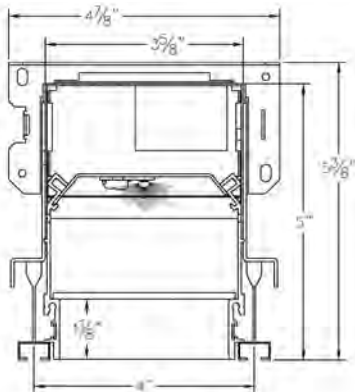

Regressed - (RLP)

Ceiling Trim

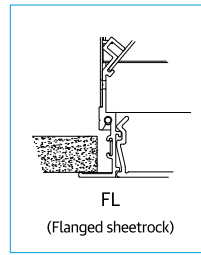

FL
(Flanged sheetrock)

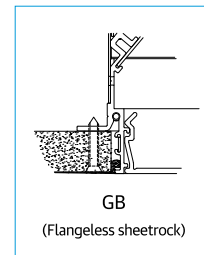

GB
(Flangeless sheetrock)

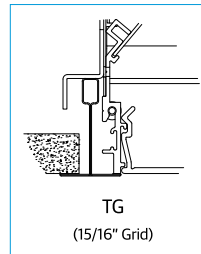

TG
(15/16" Grid)

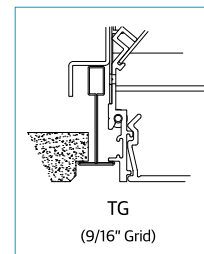

TG
(9/16" Grid)

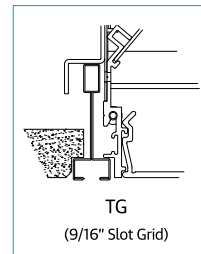

TG
(9/16" Slot Grid)

TG ceiling trim is suitable to mounted to a 4" techzone ceiling type.

Emergency Battery

Internally Mounted (E10WLCP)

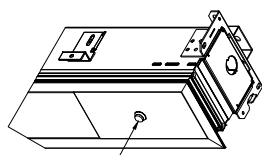

TEST SWITCH /
INDICATOR LIGHT

Notes

- Delivers 700 lumens per 4FT length. Default location is the right side of fixture and end of run.
- Provided with 4FT of flexible conduit. Maximum of 25FT remote distance if extended. Extension provided by others.
- See ordering tree notes for remote battery pack scenarios.

Remote Mounted (RE10WLCP)

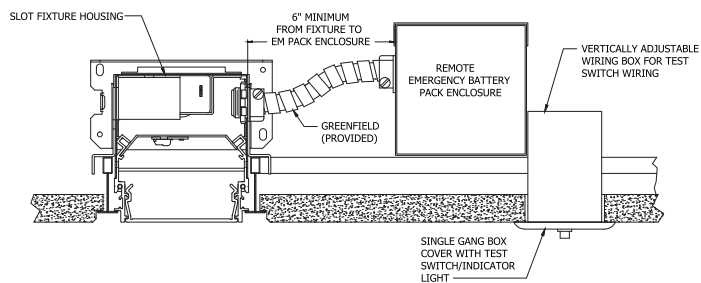

nLight Air Wireless

nLight Air

The default location of the antenna will be at the left end of an individual unit. On a run, it will be placed at the beginning or left end of the first section. Please consult factory for other placement options.

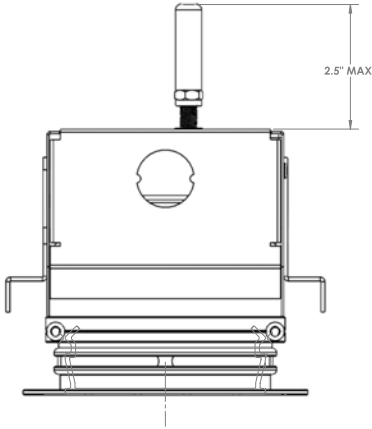

Downlights

Optional downlights powered by Xicato Spot Modules are available with any linear length and no less than 2' on center spacing. Each downlight module is 6W with 700 lumens delivered (28 degree beam spread). Downlights are supplied with a dedicated feed-point and will be controlled separately.

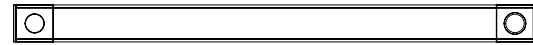
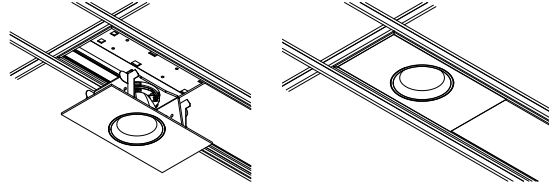

Standard Downlight Location

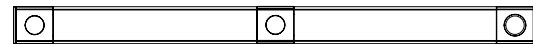

Other Downlight Configuration (consult factory)

Notes

- 2DL - Downlights are supplied at each end of an individual unit
- _DL - Multiple downlights will be supplied with one at each end and the remainder will be centered over the length of the run.
- Downlights are not adjustable and are provided with solite lens

Continuous Runs

Slot 4 LED continuous rows can be configured in 1" increments.

Run Patterns, Corners and Junction

Slot 4 LED patterns be configured in 1' increments with illuminated 90° inside and outside corners, T junctions, and X junctions with standard 2' corner and junction lengths. For custom angles, corner or junction lengths, consult factory.

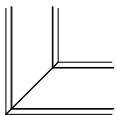

90° Corner

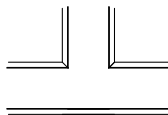

T Junction

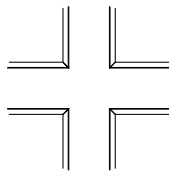

X Junction

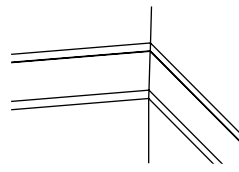

Inside Corner

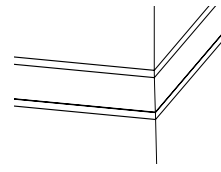

Outside Corner

Layout Sketch

Please draw and configure your linear run below.

OPTICS

Slot LED's patent-pending, precision lumen DIRECTIR optics condition and refract light to deliver accurately controlled, striation-free, and uniform white light. All lumen DIRECTIR optics are injection-molded, optical grade, UV-resistant acrylic with selective finishing/polishing treatment.

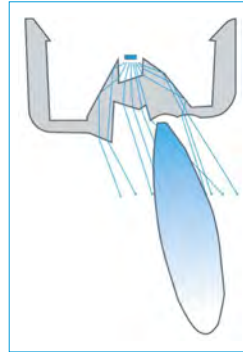
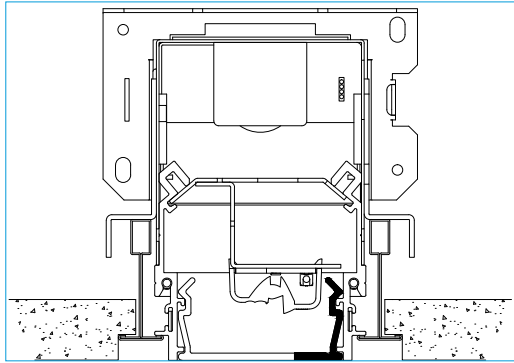

Wall Wash (WW)

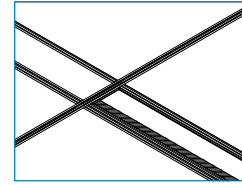

INTEGRATED SENSOR LAYOUT

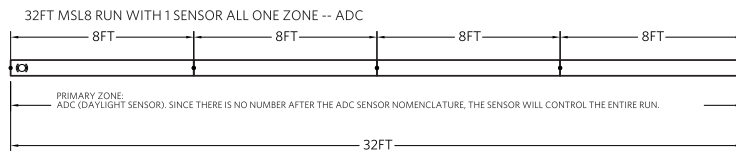

Notes:

- Only one sensor per zone

OCCUPANCY DETECTION COVERAGE

At the 7.5 ft (2.9 m) hanging height of a typical pendant mount fixture the sensor provides 10 ft (3.05 m) radial detection of small motion. At a 9 ft (2.74 m) hanging height the radius is 12 ft (3.66 m) for small motion.

Adequate for walking motion detection from mounting heights between 7.5 ft (2.29 m) and 20 ft (6.10 m).

Initial detection will occur earlier when walking across sensor's field of view than when walking directly at sensor.

Initial detection of walking motion into long coverage segment will occur at distances of 2x the mounting height up to 15 ft (4.57 m) and 1.75x up to 20 ft (6.10 m). Lens assembly rotates 15° to enable adjustment in order to line up long segments.

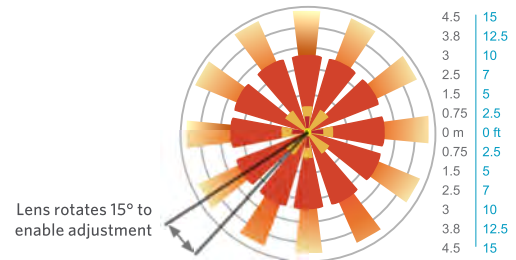

UGR CHART

Lumen Package	UGR (70% 50% 20% REFLECTANCE USING A 4H X 8H ROOM SIZE)					
	Crosswise			Endwise		
	FLP	RLP	WW	FLP	RLP	WW
400LMF	21.4	20.8	20.2	21.4	17.8	18.7
600LMF	23.3	22.7	22.1	23.3	19.7	20.6
800LMF	24.4	23.7	23.2	24.3	20.8	21.6
1000LMF	25.2	24.5	24	25.1	21.6	22.4

*UGR varies based on luminaire options and is affected by application dependent parameters. Numbers depicted here are considered "Luminaire-UGR" and/or "Point-UGR" values. To determine a more precise maximum UGR value ("Application-UGR"), a full lighting design layout should be completed with the selected luminaire configuration for each application.

MODEL **RGR4-CC**
NAME **ELEMENT**
4-Inch Regressed Downlight

When choosing a recessed fixture, eliminating glare is a priority. The unique positioning of the LED module in this series of downlights will meet that important need.

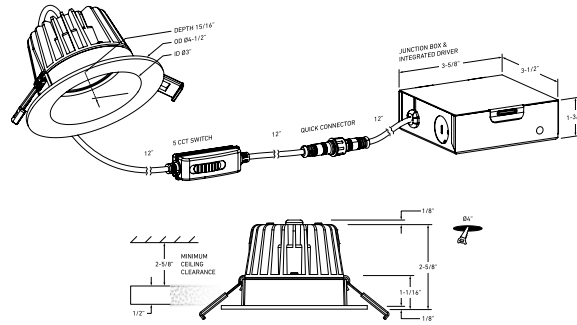

PROJECT: _____ **TYPE:** _____
DATE: _____ **QTY:** _____
NOTES: _____

QUICK SPECS

SIZE	WATTS	DELIVERED LUMENS*	COLOR °T 5CCT	CRI	VOLTAGE	BEAM ANGLE	FINISH
4"	15W	1100lm	2700K 3000K 3500K 4000K 5000K	90	120V	40°	<input type="radio"/> White <input type="checkbox"/> <input type="radio"/> Satin Nickel <input type="checkbox"/> <input checked="" type="radio"/> Black <input type="checkbox"/>

*Lumen output measured at 3000K

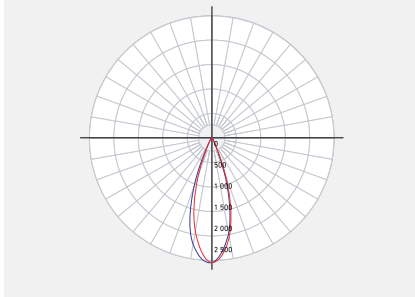
LIGHT DISTRIBUTION

CONSTRUCTION	Lens	Type of optics	Type of LED
	Clear	Optical lens	COB
	Lens material	Housing material	Cut hole size
	Acrylic	Cast aluminum	4"

RATINGS	Placement	Lifespan	FT rating
	Indoor/Outdoor	50,000 hrs.	FT6
	Location	Certifications	Operating temperature
	Wet	ETL, FCC, ICES, ES IC, ASTM E283-04, T24	-20° to 40° C

WHAT'S IN THE BOX

- LED recessed fixture
- Junction box
- Push-in wire connectors
- Mounting hardware
- Instruction sheet

ACCESSORIES

- RFP-UNI**
Universal Drilling Plate
- RFP-35**
Drilling Plate

ADAPTERS

- REC-EXT108**
108" extension cord for recessed fixtures
- REC-EXT230**
230" extension cord for recessed fixtures

RGR4-CC | dals.com



ELECTRICAL DETAILS	Input voltage	Output current	Power factor	Driver type
	108-135V	330mA	99%	Constant current
	Output voltage	LED model #	THD harmonic distortion	Binning type
	35V	COB	<30%	3 SDCM

FEATURES	Every fixture includes a junction box with an integrated driver	Superior LED performance and lifespan	Switch-selectable CCT: 2700K/ 3000 K/ 3500 K/ 4000 K/ 5000 K
	Can be daisy chained	Smooth 360° wide spread	

WARRANTY DALs offers a 5-year warranty from the date of purchase which covers repairs or replacement of defective parts of the housing, optics, and electronics. To contact DALs customer service call 1-877-430-1818 or send an e-mail to info@dals.com.

RECOMMENDED DIMMER LIST*

BRAND	MODEL #	DIMMER SPECS	GRADE	DIMMING RANGE (%)	MAX LOAD
Dals	SM-DIMSW Smart Dimmer	Triac, 250W LED/CFL	Compatible	Min: 8 / Max: 99	17
Lutron	DVCL-153PR-WH-C	Triac, 150 W Dimmable CFL/LED	Compatible	Min: 10 / Max: 100	10
Lutron	CTCL-153PDH-WH-C	Triac, 150 W Dimmable CFL/LED	Compatible	Min: 9 / Max: 100	10
Lutron	STCL-153PH-WH-C	Triac, 150 W Dimmable CFL/LED	Compatible	Min: 3 / Max: 100	10
Lutron	DVWCL-153PH-WHC	Triac, 150 W Dimmable CFL/LED	Compatible	Min: 10 / Max: 100	10
Lutron	MACL-153MRHW-WHC	Triac, 150 W Dimmable CFL/LED	Compatible	Min: 2 / Max: 100	10
Lutron	DVELV-300P-WH	300W electronic low voltage dimmer	Compatible	Min: 10 / Max: 100	21
Lutron	MA-PRO-WH	ELV, 250W LED/CFL	Compatible	Min: 3 / Max: 100	17
Lutron	Caseta PD-6WCL-WH-R-C	Triac, 300W Dimmable CFL/LED	Compatible	Min: 1 / Max: 100	17
Lutron	Caseta PD-5NE-WH-C	ELV, LED—up to 250 W	Compatible	Min: 5 / Max: 100	17
Lutron	Caseta PD-10NXD-WH	Triac, LED—up to 250 W	Compatible	Min: 2 / Max: 100	10
Leviton	6672-1LW	Triac, 150W Dimmable CFL/LED	Compatible	Min: 25 / Max: 99	10
Leviton	DSM10	Triac, 450W Dimmable CFL/LED	Compatible	Min: 21 / Max: 100	32
Leviton	6674	Triac, 150 W Dimmable CFL/LED	Compatible	Min: 12 / Max: 99	10
Leviton	IPL06-10Z	Triac, 150 W Dimmable CFL/LED	Compatible	Min: 19 / Max: 99	10
Leviton	DSL06-752	Triac, 150 W Dimmable CFL/LED	Compatible	Min: 19 / Max: 99	10
Leviton	D26HD-742-1RW	Triac, 300W LED/CFL	Compatible	Min: 12 / Max: 99	21
Legrand	RHCL453PNICCV4	Triac, 450W Dimmable CFL/LED	Compatible	Min: 13 / Max: 100	21
Legrand	ADTP703TUM4	Triac, 450W Dimmable CFL/LED	Compatible	Min: 13 / Max: 100	21
Legrand	ADPD453LM2	Triac, 450W Dimmable CFL/LED	Compatible	Min: 12 / Max: 99	21
Legrand	RHL373PW	Triac, 250W LED	Compatible	Min: 9 / Max: 98	17
Control 4	C4-APD120-WH	ELV, 120W LED	Compatible	Min: 1 / Max: 99	8
Control 4	C4-FPD120-WH	Triac, 200W LED	Compatible	Min: 1 / Max: 98	14

* Minimal buzzing noise may occur with some dimmers

RGR4-CC | dals.com



Catalog Information:

RGR4-CC-4-15W-1100LM-3500K-90-120V-40-WHITE

Date:01/27/2023

Fixture Type:

A17



Guardian™

2-116-T | Standard LED

Round Wall Wash

Our tamper-resistant downlight, Guardian™, is ideal for hospitals, correctional facilities, schools or anywhere security is a concern. This sturdy yet beautiful fixture is available in a wide array of luminance choices. So, if you're looking for an affordable downlight that will help keep patients safe, we've got just the prescription.

FEATURES

- Ø 3 1/2" [89mm] Aperture
- Ligature resistant design
- Damp location listed, optional wet location with IP65 rating, protected from total dust ingress and low pressure water jets from any direction
- IK10 rated. Protected against 20 joules impact
- Vandal resistant trim ring is made of machined aluminum and powder coated
- Flush lens design with 1/8" thick inner Solite softening glass and an outer protective 3/16" thick clear polycarbonate lens
- Vandal resistant stainless steel T-15 torx security screws
- Wall wash comes with rotation adjustment setting. Ideal spacing 24" on center and 24" away from the wall

LISTINGS



IK10



IP65



Antimicrobial

DIMENSIONS

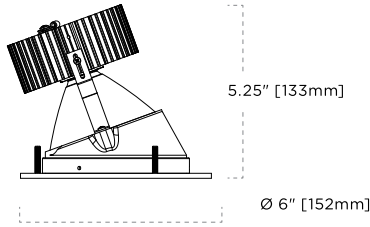

PERFORMANCE SUMMARY

Color Accuracy (SDCM)	<3	
L70 Estimate (h)	50,000	
Color Rendering (CRI)	80	90
Lumen Series	3	
Source Lumens	1400	1000
LED Wattage	11	11
Lumen Series	5	
Source Lumens	1800	1400
LED Wattage	17	17
Lumen Series	7	
Source Lumens	2300	1800
LED Wattage	24	24
Lumen Series	9	
Source Lumens	3000	2300
LED Wattage	28	28

2-116-T-Guardian-Round-Wall-Wash-Standard-LED-Specs p. 1/3

Product specifications and dimensions are subject to change without notice

All rights reserved. © 2020 Lightheaded Lighting Ltd. Rev 2020.10.05

info@lightheadedlighting.com P. 604.464.5644 T. 1.800.464.9544

LIGHTHEADED™



Catalog Information: LUMINAIRE: 2-116-T-[FINISH]-BROWW-35-9010-WET
HOUSING: D4B-FVR-R-T-3-P-277-BP

Date: 02/08/2023
Fixture Type:

A20



2-116-T | Standard LED

Round Wall Wash



TAG TYPE

Blank bar for tag type

ORDER FORM

1	2	3	4	5	6

1. TRIM

2-116-T Vandal Resistant

2. FLANGE FINISH

- 01 White
- 04 Black
- 05 Matte Silver
- 06 Bronze
- 11 Matte Nickel
- CC Custom Color¹

3. MODULE & BEAM SPREAD

BROWW Wall Wash²

4. COLOR TEMPERATURE

- 27 2700K
- 30 3000K
- 35 3500K
- 40 4000K

5. CRI, LUMENS, SERIES

- 8014 80 CRI, 1400lm, 3 Series
- 9010 90 CRI, 1000lm, 3 Series
- 8018 80 CRI, 1800lm, 5 Series
- 9014 90 CRI, 1400lm, 5 Series
- 8023 80 CRI, 2300lm, 7 Series
- 9018 90 CRI, 1800lm, 7 Series
- 8030 80 CRI, 3000lm, 9 Series
- 9023 90 CRI, 2300lm, 9 Series

6. OPTIONS

- WET Wet Location³
- AM Antimicrobial Finish⁴

NOTES

- 1 CC custom color requires consultation with Lighthouse sales personnel.
- 2 BROWW Wall Wash comes with diffusion lens and rotation adjustment setting.
- 3 WET location has IP65 rating, protected from total dust ingress and low pressure water jets from any direction.
- 4 Provides protection against bacteria, mold and fungi by up to 99.99%. Only available in white. Consult Lighthouse sales personnel for availability of additional colors.

2-116-T-Guardian-Round-Wall-Wash-Standard-LED-Specs p. 2/3

Product specifications and dimensions are subject to change without notice

All rights reserved. © 2020 Lighthouse Lighting Ltd. Rev 2020.10.05

info@lighthouselighting.com P. 604.464.5644 T. 1.800.464.9544



Catalog

Information:

LUMINAIRE: 2-116-T-[FINISH]-BROWW-35-9010-WET

HOUSING: D4B-FVR-R-T-3-P-277-BP

Date:02/08/2023

Fixture Type:

A20

SPECIFICATIONS

FLANGE FINISHES

-  White
-  Black
-  Matte Silver
-  Bronze
-  Matte Nickel

COLOR TEMPERATURES

-  2700K
-  3000K
-  3500K
-  4000K

BEAM SPREADS



COMPATIBLE HOUSINGS

NON-INSULATED/FRAME IN

D4B-FVR-R-T
3, 5 Series
L 10.5" W 7.75" H 5.5"
L 267mm W 197mm H 140mm

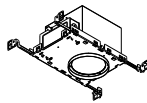

D4B-FVR-R-T
7, 9 Series
L 13.75" W 10.875" H 5.5"
L 350mm W 277mm H 140mm

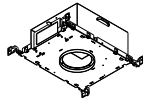

INSULATED AIRTIGHT

D4B-IC1VR-R
3, 5 Series
L 22.5" W 8.5" H 5.875"
L 572mm W 216mm H 150mm

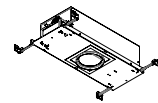

CERTIFICATIONS



2-116-T-Guardian-Round-Wall-Wash-Standard-LED-Specs p. 3/3

Product specifications and dimensions are subject to change without notice

All rights reserved. © 2020 Lighthouse Lighting Ltd. Rev 2020.10.05

info@lighthouselighting.com P. 604.464.5644 T. 1.800.464.9544

LIGHTHEADED™



Catalog Information: LUMINAIRE: 2-116-T-[FINISH]-BROWW-35-9010-WET
HOUSING: D4B-FVR-R-T-3-P-277-BP

Date: 02/08/2023
Fixture Type:

A20

Page: 3 of 5



Guardian™

D4B-FVR-R | Standard LED

Round Non-Insulated

Our tamper-resistant downlight, Guardian™, is ideal for hospitals, correctional facilities, schools or anywhere security is a concern. This sturdy yet beautiful fixture is available in a wide array of luminance choices and beam spreads. So, if you're looking for an affordable downlight that will help keep patients safe, we've got just the prescription.

FEATURES

- Rated for non-insulated ceilings to a max ambient temperature of 45°C [113°F] with 3, 5 series
- Rated for non-insulated ceilings to a max ambient temperature of 40°C [104°F] with 7, 9 series
- Bi-directional mounting
- 14"-25" adjustable hanger bars
- 18 Ga. galvanized steel junction box with multiple KO
- 20 Ga. black powder coated steel baseplate

CEILING CUTOUT

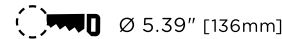

CERTIFICATIONS



DIMENSIONS—TRIMMED + APERTURE COLLAR (3, 5 SERIES)

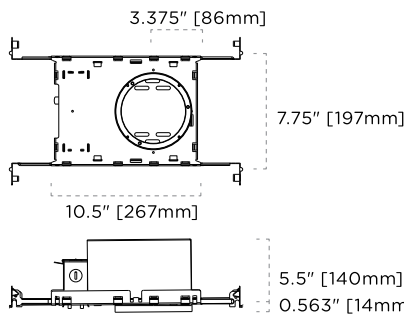

DIMENSIONS—TRIMMED + APERTURE COLLAR (7, 9 SERIES)

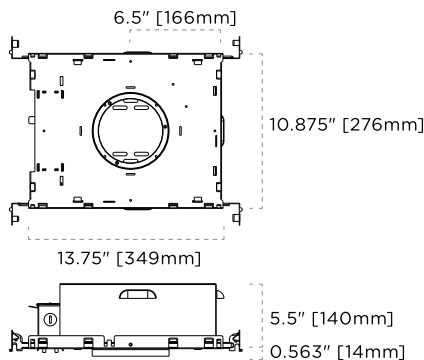

D4B-FVR-R-Specs p. 1/2

Product specifications and dimensions are subject to change without notice

All rights reserved. © 2021 Lightheaded Lighting Ltd. Rev 2021.01.15

info@lightheadedlighting.com P. 604.464.5644 T. 1.800.464.9544

LIGHTHEADED™



Catalog Information: LUMINAIRE: 2-116-T-[FINISH]-BROWW-35-9010-WET
HOUSING: D4B-FVR-R-T-3-P-277-BP

Date:02/08/2023
Fixture Type:

A20



D4B-FVR-R | Standard LED

Round Non-Insulated



TAG TYPE

Blank tag type field

ORDER FORM

1	2	3	4	5	6

1. HOUSING

D4B-FVR-R

2. FLANGE TYPE¹

T Trimmed

3. SERIES¹

3 BRO 1400 Lumens Max.

5 BRO 1800 Lumens Max.

7 BRO 2300 Lumens Max.

9 BRO 3000 Lumens Max.

4. DIMMING

D DALI (1%)

LE Lutron Phase (1%)²

LH Lutron EcoSystem (1%)

P 0-10V Dimming (1%)

P1 eidoLED Dimming (1%)

S Phase Dimming (5%)

5. VOLTAGE

120

277

347³

6. OPTIONS

BP Black Painted Interior

WP White Painted Interior

NOTES

1 Ensure trim compatibility prior to housing order. Conditions may apply.

2 LE and S dimming is only available in 120V.

3 347V is only available in P dimming.

D4B-FVR-R-Specs p. 2/2

Product specifications and dimensions are subject to change without notice

All rights reserved. © 2021 Lighthouse Lighting Ltd. Rev 2021.01.15

info@lighthouselighting.com P. 604.464.5644 T. 1.800.464.9544



Catalog

Information:

LUMINAIRE: 2-116-T-[FINISH]-BROWW-35-9010-WET

HOUSING: D4B-FVR-R-T-3-P-277-BP

Date:02/08/2023

Fixture Type:

A20



Guardian™

2-116-T | Standard LED

Round Downlight

Our tamper-resistant downlight, Guardian™, is ideal for hospitals, correctional facilities, schools or anywhere security is a concern. This sturdy yet beautiful fixture is available in a wide array of luminance choices. So, if you're looking for an affordable downlight that will help keep patients safe, we've got just the prescription.

FEATURES

- Ø 3 1/2" [89mm] Aperture
- Ligature resistant design
- Damp location listed, optional wet location with IP65 rating, protected from total dust ingress and low pressure water jets from any direction
- IK10 rated. Protected against 20 joules impact
- Vandal resistant trim ring is made of machined aluminum and powder coated
- Flush lens design with 1/8" thick inner Solite softening glass and an outer protective 3/16" thick clear polycarbonate lens
- Vandal resistant stainless steel T-15 torx security screws

LISTINGS



IK10



IP65



Antimicrobial

DIMENSIONS

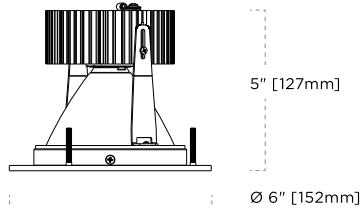

PERFORMANCE SUMMARY

Color Accuracy (SDCM)	<3	
L70 Estimate (h)	50,000	
Color Rendering (CRI)	80	90
Lumen Series	3	
Source Lumens	1400	1000
LED Wattage	11	11
Lumen Series	5	
Source Lumens	1800	1400
LED Wattage	17	17
Lumen Series	7	
Source Lumens	2300	1800
LED Wattage	24	24
Lumen Series	9	
Source Lumens	3000	2300
LED Wattage	28	28

2-116-T-Guardian-Round-Downlight-Standard-LED-Specs p. 1/3

Product specifications and dimensions are subject to change without notice

All rights reserved. © 2020 Lighthouse Lighting Ltd. Rev 2020.10.05

info@lighthouse lighting.com P. 604.464.5644 T. 1.800.464.9544

LIGHTHEADED™



Catalog Information: LUMINAIRE: 2-116-T-CC-BRO60-35-9010-WET
HOUSING: D4B-FVR-R-T-3-P-277-BP

Date: 02/08/2023
Fixture Type:

A21



2-116-T | Standard LED

Round Downlight



TAG TYPE

Blank bar for tag type

ORDER FORM

1	2	3	4	5	6

1. TRIM

2-116-T Vandal Resistant

2. FLANGE FINISH

- 01 White
- 04 Black
- 05 Matte Silver
- 06 Bronze
- 11 Matte Nickel
- CC Custom Color¹**

3. MODULE & BEAM SPREAD

- BRO11** 11° Beam
- BRO28** 28° Beam
- BRO36** 36° Beam
- BRO60** 60° Beam

4. COLOR TEMPERATURE

- 27 2700K
- 30 3000K
- 35 3500K**
- 40 4000K

5. CRI, LUMENS, SERIES

- 8014** 80 CRI, 1400lm, 3 Series
- 9010** 90 CRI, 1000lm, 3 Series
- 8018** 80 CRI, 1800lm, 5 Series
- 9014** 90 CRI, 1400lm, 5 Series
- 8023** 80 CRI, 2300lm, 7 Series
- 9018** 90 CRI, 1800lm, 7 Series
- 8030** 80 CRI, 3000lm, 9 Series
- 9023** 90 CRI, 2300lm, 9 Series

6. OPTIONS

- WET** Wet Location ²
- AM** Antimicrobial Finish ³

NOTES

- 1** CC custom color requires consultation with Lighthouse sales personnel.
- 2** WET location has IP65 rating, protected from total dust ingress and low pressure water jets from any direction.
- 3** Provides protection against bacteria, mold and fungi by up to 99.99%. Only available in white. Consult Lighthouse sales personnel for availability of additional colors.

2-116-T-Guardian-Round-Downlight-Standard-LED-Specs p. 2/3

Product specifications and dimensions are subject to change without notice

All rights reserved. © 2020 Lighthouse Lighting Ltd. Rev 2020.10.05

info@lighthouselighting.com P. 604.464.5644 T. 1.800.464.9544



Catalog Information:

LUMINAIRE: 2-116-T-CC-BRO60-35-9010-WET
HOUSING: D4B-FVR-R-T-3-P-277-BP

Date:02/08/2023
Fixture Type:

A21

SPECIFICATIONS

FLANGE FINISHES

-  White
-  Black
-  Matte Silver
-  Bronze
-  Matte Nickel

COLOR TEMPERATURES

-  2700K
-  3000K
-  3500K
-  4000K

BEAM SPREADS

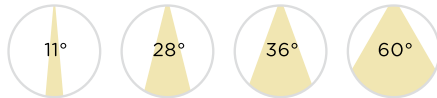

COMPATIBLE HOUSINGS

NON-INSULATED/FRAME IN

D4B-FVR-R-T
3, 5 Series
L 10.5" W 7.75" H 5.5"
L 267mm W 197mm H 140mm

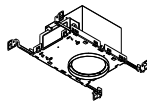

D4B-FVR-R-T
7, 9 Series
L 13.75" W 10.875" H 5.5"
L 350mm W 277mm H 140mm

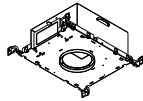

INSULATED AIRTIGHT

D4B-IC1VR-R
3, 5 Series
L 22.5" W 8.5" H 5.875"
L 572mm W 216mm H 150mm

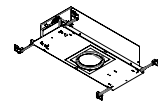

CERTIFICATIONS



2-116-T-Guardian-Round-Downlight-Standard-LED-Specs p. 3/3

Product specifications and dimensions are subject to change without notice

All rights reserved. © 2020 Lighthouse Lighting Ltd. Rev 2020.10.05

info@lighthouselighting.com P. 604.464.5644 T. 1.800.464.9544

LIGHTHEADED™



Catalog Information: LUMINAIRE: 2-116-T-CC-BRO60-35-9010-WET
HOUSING: D4B-FVR-R-T-3-P-277-BP

Date: 02/08/2023
Fixture Type:

A21



Guardian™

D4B-FVR-R | Standard LED

Round Non-Insulated

Our tamper-resistant downlight, Guardian™, is ideal for hospitals, correctional facilities, schools or anywhere security is a concern. This sturdy yet beautiful fixture is available in a wide array of luminance choices and beam spreads. So, if you're looking for an affordable downlight that will help keep patients safe, we've got just the prescription.

FEATURES

- Rated for non-insulated ceilings to a max ambient temperature of 45°C [113°F] with 3, 5 series
- Rated for non-insulated ceilings to a max ambient temperature of 40°C [104°F] with 7, 9 series
- Bi-directional mounting
- 14"-25" adjustable hanger bars
- 18 Ga. galvanized steel junction box with multiple KO
- 20 Ga. black powder coated steel baseplate

CEILING CUTOUT

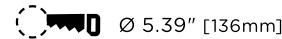

CERTIFICATIONS



DIMENSIONS—TRIMMED + APERTURE COLLAR (3, 5 SERIES)

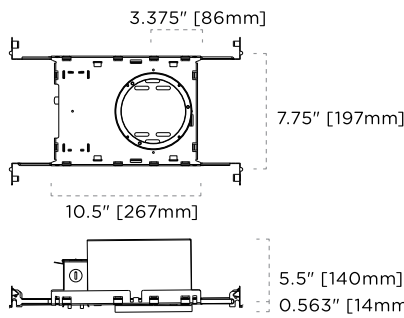

DIMENSIONS—TRIMMED + APERTURE COLLAR (7, 9 SERIES)

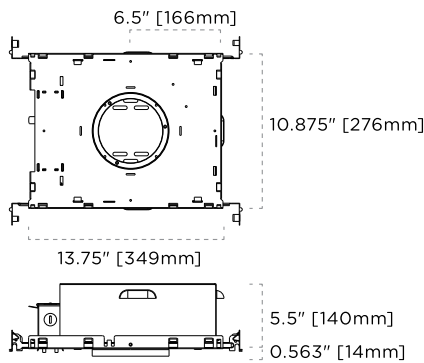

D4B-FVR-R-Specs p. 1/2

Product specifications and dimensions are subject to change without notice

All rights reserved. © 2021 Lightheaded Lighting Ltd. Rev 2021.01.15

info@lightheadedlighting.com P. 604.464.5644 T. 1.800.464.9544

LIGHTHEADED™



Catalog Information: LUMINAIRE: 2-116-T-CC-BRO60-35-9010-WET
HOUSING: D4B-FVR-R-T-3-P-277-BP

Date: 02/08/2023
Fixture Type:

A21



D4B-FVR-R | Standard LED

Round Non-Insulated



TAG TYPE

Blank tag type field

ORDER FORM

1	2	3	4	5	6

1. HOUSING

D4B-FVR-R

2. FLANGE TYPE¹

T Trimmed

3. SERIES¹

3 BRO 1400 Lumens Max.

5 BRO 1800 Lumens Max.

7 BRO 2300 Lumens Max.

9 BRO 3000 Lumens Max.

4. DIMMING

D DALI (1%)

LE Lutron Phase (1%)²

LH Lutron EcoSystem (1%)

P 0-10V Dimming (1%)

P1 eidoLED Dimming (1%)

S Phase Dimming (5%)

5. VOLTAGE

120

277

347³

6. OPTIONS

BP Black Painted Interior

WP White Painted Interior

NOTES

1 Ensure trim compatibility prior to housing order. Conditions may apply.

2 LE and S dimming is only available in 120V.

3 347V is only available in P dimming.

D4B-FVR-R-Specs p. 2/2

Product specifications and dimensions are subject to change without notice

All rights reserved. © 2021 Lighthouse Lighting Ltd. Rev 2021.01.15

info@lighthouselighting.com P. 604.464.5644 T. 1.800.464.9544



Catalog

Information:

LUMINAIRE: 2-116-T-CC-BRO60-35-9010-WET

HOUSING: D4B-FVR-R-T-3-P-277-BP

Date:02/08/2023

Fixture Type:

A21



Guardian™

2-116-T | Standard LED

Round Downlight

Our tamper-resistant downlight, Guardian™, is ideal for hospitals, correctional facilities, schools or anywhere security is a concern. This sturdy yet beautiful fixture is available in a wide array of luminance choices. So, if you're looking for an affordable downlight that will help keep patients safe, we've got just the prescription.

FEATURES

- Ø 3 1/2" [89mm] Aperture
- Ligature resistant design
- Damp location listed, optional wet location with IP65 rating, protected from total dust ingress and low pressure water jets from any direction
- IK10 rated. Protected against 20 joules impact
- Vandal resistant trim ring is made of machined aluminum and powder coated
- Flush lens design with 1/8" thick inner Solite softening glass and an outer protective 3/16" thick clear polycarbonate lens
- Vandal resistant stainless steel T-15 torx security screws

LISTINGS



IK10



IP65



Antimicrobial

DIMENSIONS

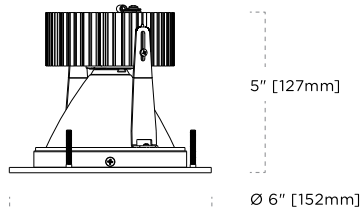

PERFORMANCE SUMMARY

Color Accuracy (SDCM)	<3	
L70 Estimate (h)	50,000	
Color Rendering (CRI)	80	90
Lumen Series	3	
Source Lumens	1400	1000
LED Wattage	11	11
Lumen Series	5	
Source Lumens	1800	1400
LED Wattage	17	17
Lumen Series	7	
Source Lumens	2300	1800
LED Wattage	24	24
Lumen Series	9	
Source Lumens	3000	2300
LED Wattage	28	28

2-116-T-Guardian-Round-Downlight-Standard-LED-Specs p. 1/3

Product specifications and dimensions are subject to change without notice

All rights reserved. © 2020 Lighthouse Lighting Ltd. Rev 2020.10.05

info@lighthouselighting.com P. 604.464.5644 T. 1.800.464.9544

LIGHTHEADED™



Catalog Information: LUMINAIRE: 2-116-T-01-BRO60-35-9010
HOUSING: D4B-FVR-R-T-3-P-277-BP

Date: 02/08/2023
Fixture Type:

A21A



2-116-T | Standard LED

Round Downlight



TAG TYPE

Blank bar for tag type

ORDER FORM

1	2	3	4	5	6

1. TRIM

2-116-T Vandal Resistant

2. FLANGE FINISH

- 01** White
- 04** Black
- 05** Matte Silver
- 06** Bronze
- 11** Matte Nickel
- CC** Custom Color¹

3. MODULE & BEAM SPREAD

- BRO11** 11° Beam
- BRO28** 28° Beam
- BRO36** 36° Beam
- BRO60** 60° Beam

4. COLOR TEMPERATURE

- 27** 2700K
- 30** 3000K
- 35** 3500K
- 40** 4000K

5. CRI, LUMENS, SERIES

- 8014** 80 CRI, 1400lm, 3 Series
- 9010** 90 CRI, 1000lm, 3 Series
- 8018** 80 CRI, 1800lm, 5 Series
- 9014** 90 CRI, 1400lm, 5 Series
- 8023** 80 CRI, 2300lm, 7 Series
- 9018** 90 CRI, 1800lm, 7 Series
- 8030** 80 CRI, 3000lm, 9 Series
- 9023** 90 CRI, 2300lm, 9 Series

6. OPTIONS

- WET** Wet Location ²
- AM** Antimicrobial Finish ³

NOTES

- 1** CC custom color requires consultation with Lightheaded sales personnel.
- 2** WET location has IP65 rating, protected from total dust ingress and low pressure water jets from any direction.
- 3** Provides protection against bacteria, mold and fungi by up to 99.99%. Only available in white. Consult Lightheaded sales personnel for availability of additional colors.

2-116-T-Guardian-Round-Downlight-Standard-LED-Specs p. 2/3

Product specifications and dimensions are subject to change without notice

All rights reserved. © 2020 Lightheaded Lighting Ltd. Rev 2020.10.05

info@lightheadedlighting.com P. 604.464.5644 T. 1.800.464.9544



Catalog Information: LUMINAIRE: 2-116-T-01-BRO60-35-9010 HOUSING: D4B-FVR-R-T-3-P-277-BP

Date:02/08/2023
Fixture Type:

A21A

SPECIFICATIONS

FLANGE FINISHES

-  White
-  Black
-  Matte Silver
-  Bronze
-  Matte Nickel

COLOR TEMPERATURES

-  2700K
-  3000K
-  3500K
-  4000K

BEAM SPREADS

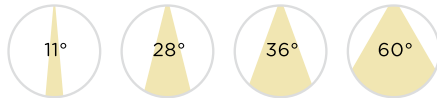

COMPATIBLE HOUSINGS

NON-INSULATED/FRAME IN

D4B-FVR-R-T
3, 5 Series
L 10.5" W 7.75" H 5.5"
L 267mm W 197mm H 140mm

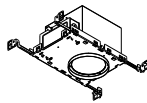

D4B-FVR-R-T
7, 9 Series
L 13.75" W 10.875" H 5.5"
L 350mm W 277mm H 140mm

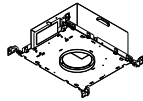

INSULATED AIRTIGHT

D4B-IC1VR-R
3, 5 Series
L 22.5" W 8.5" H 5.875"
L 572mm W 216mm H 150mm

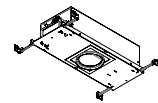

CERTIFICATIONS



2-116-T-Guardian-Round-Downlight-Standard-LED-Specs p. 3/3

Product specifications and dimensions are subject to change without notice

All rights reserved. © 2020 Lighthouse Lighting Ltd. Rev 2020.10.05

info@lighthouselighting.com P. 604.464.5644 T. 1.800.464.9544

LIGHTHEADED™



Catalog Information: LUMINAIRE: 2-116-T-01-BRO60-35-9010
HOUSING: D4B-FVR-R-T-3-P-277-BP

Date: 02/08/2023
Fixture Type:

A21A



Guardian™

D4B-FVR-R | Standard LED

Round Non-Insulated

Our tamper-resistant downlight, Guardian™, is ideal for hospitals, correctional facilities, schools or anywhere security is a concern. This sturdy yet beautiful fixture is available in a wide array of luminance choices and beam spreads. So, if you're looking for an affordable downlight that will help keep patients safe, we've got just the prescription.

FEATURES

- Rated for non-insulated ceilings to a max ambient temperature of 45°C [113°F] with 3, 5 series
- Rated for non-insulated ceilings to a max ambient temperature of 40°C [104°F] with 7, 9 series
- Bi-directional mounting
- 14"-25" adjustable hanger bars
- 18 Ga. galvanized steel junction box with multiple KO
- 20 Ga. black powder coated steel baseplate

CEILING CUTOUT

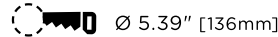

CERTIFICATIONS



DIMENSIONS—TRIMMED + APERTURE COLLAR (3, 5 SERIES)

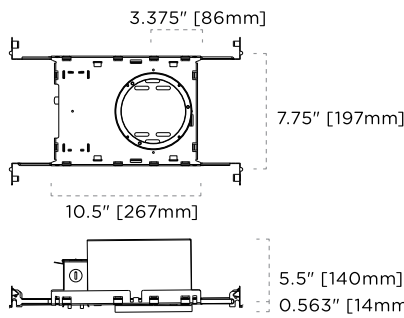

DIMENSIONS—TRIMMED + APERTURE COLLAR (7, 9 SERIES)

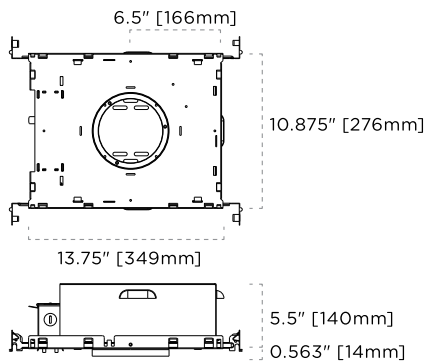

D4B-FVR-R-Specs p. 1/2

Product specifications and dimensions are subject to change without notice

All rights reserved. © 2021 Lightheaded Lighting Ltd. Rev 2021.01.15

info@lightheadedlighting.com P. 604.464.5644 T. 1.800.464.9544

LIGHTHEADED™



Catalog Information: LUMINAIRE: 2-116-T-01-BRO60-35-9010
HOUSING: D4B-FVR-R-T-3-P-277-BP

Date: 02/08/2023
Fixture Type:

A21A



D4B-FVR-R | Standard LED

Round Non-Insulated



TAG TYPE

Blank tag type field

ORDER FORM

1	2	3	4	5	6

1. HOUSING

D4B-FVR-R

2. FLANGE TYPE¹

T Trimmed

3. SERIES¹

3 BRO 1400 Lumens Max.

5 BRO 1800 Lumens Max.

7 BRO 2300 Lumens Max.

9 BRO 3000 Lumens Max.

4. DIMMING

D DALI (1%)

LE Lutron Phase (1%)²

LH Lutron EcoSystem (1%)

P 0-10V Dimming (1%)

P1 eLdoLED Dimming (1%)

S Phase Dimming (5%)

5. VOLTAGE

120

277

347³

6. OPTIONS

BP Black Painted Interior

WP White Painted Interior

NOTES

1 Ensure trim compatibility prior to housing order. Conditions may apply.

2 LE and S dimming is only available in 120V.

3 347V is only available in P dimming.

D4B-FVR-R-Specs p. 2/2

Product specifications and dimensions are subject to change without notice

All rights reserved. © 2021 Lighthouse Lighting Ltd. Rev 2021.01.15

info@lighthouselighting.com P. 604.464.5644 T. 1.800.464.9544



Catalog Information: LUMINAIRE: 2-116-T-01-BRO60-35-9010
HOUSING: D4B-FVR-R-T-3-P-277-BP

Date:02/08/2023
Fixture Type:

A21A

MILLENIUM STRETCH™

MLHA8 SERIES

PRODUCT FEATURES:

- » Surface mount – wall or ceiling; nominal 8" x 24", 8" x 36" 8" x 48", 8" x 72", 8" x 96"
- » Extruded aluminum housing with decorative end caps
- » Peace of Mind Guarantee® against breakage
- » ADA compliant

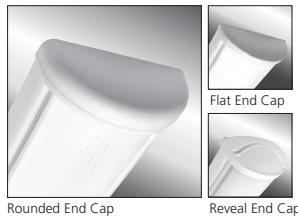

PROJECT INFORMATION

Job Name _____
 Fixture Type _____
 Catalog Number _____
 Approved by _____

SPECIFICATIONS

HOUSING: Marine grade aluminum. Extruded body with die-cast end caps. Housing, with end caps, post assembly TGIC polyester powder coat finished – 5-step pre-treatment. See Ordering Information for standard, optional, architectural and custom finishes.

REFLECTOR: Full reflector/wire cover – 92% reflectivity.

LENS: UV-stabilized, high impact extruded clear or pearlescent polycarbonate. Smooth exterior, linear prismatic interior. Nominal thickness .156". Lens securely positioned in body channels and end caps. Lens locked in place with tamper-resistant stainless steel Torx® with center pin fasteners and sealed with closed cell gaskets.

END CAPS: Marine grade die-cast aluminum. Three styles available: Flat, Rounded and Reveal. Conduit and "Wiremold™" ready" knockouts visible only from interior of end cap (Flat and Rounded styles only).

SOCKETS: Shock-resistant sockets with internal locking collar to ensure positive lamp retention.

HARDWARE: Stainless steel, tamper-resistant Torx fasteners secure lens in housing body's lens channel (four on 24", 36", and 48" housings; eight on 72" and 96" housings).

ELECTRICAL: LED: Available 3500K, 4000K and 5000K color temperatures, 82 CRI. 120-277VAC and 347VAC, 50/60Hz electrical input with serviceable high power factor electronic, constant-current driver (<20% THD, >0.95 PF). Standard 0-10V dimming with 1-100% range and dim-to-dark capabilities, maximum driver source of 330µA. Optional embedded microwave motion sensor (MS) has factory default settings of 20 minute time out, dims down to 30%. LE: Class P ballasts. Fluorescent electronic 120/277/347 and dual voltage ballasts high power factor.

INSTALLATION: Standard four-point (24" housing), six-point (36" and 48" housing) and twelve-point (72" and 96" housing) mounting required for Peace of Mind Guarantee®. LED product ambient temperature is -30°C to 40°C, unless otherwise noted.

TEKLINK™ TL50: An independent lighting control system embedded in the luminaire, featuring its own occupancy sensor, daylight harvesting and adjustable time-out/dimming settings.

TEKLINK™ TL100: Centralized, wired zonal occupancy and closed-loop daylight harvesting control system. TL100 controllers are standalone devices and ordered separately for luminaire. [Click here for specifications.](#)

PHOTOMETRICS: Photometry tested to the IESNA LM-79-08 standard by an ILAC/ISO17025 accredited laboratory. For additional photometric information, go to www.kenall.com.

WARRANTY: Limited ten (10) year warranty for LED Lamps.

LISTINGS: Luminaire is certified to UL standards by Intertek Testing Laboratories for non-IC and Wet Location installations. IP64 rating per IEC60598 – ceiling mount. Corner, horizontal wall and pendant mount installation – damp location only. ADA compliant.



ORDERING INFORMATION (Ex: MLHA8-48-F-MB-PP-45L40K-DCC-DV-FS-9500)

Model	Length	End Cap	Finish	Lens	Lamp Qty	Lamp Type	Ballast/Driver	Circuit Qty	Voltage	Options	Accessories	TekLink	Controls Kit
MLHA8													
Length	24 36 48 72 96	2' 3' 4' Two 3' (factory connected) Two 4' (factory connected)											
End Caps	F R RV	Flat Rounded Reveal											
Finish	LG MB MW CC	Light Gray Matte Black Matte White Custom Color (Consult Factory)											
Lens	CP PP	Clear Polycarbonate Pearlescent Polycarbonate											
Lamp Quantity (Cross Section)	1 2 3	One Two Three (T8 or T5 only)											
Lamp Type	25L35K 25L40K 25L50K	25 Watt 3500K LED 25 Watt 4000K LED 25 Watt 5000K LED											
Ballast/Driver Type	IS RS SB DCC	Instant Start Electronic <10% THD (T8) Rapid Start Electronic <10% THD (T8,T5,T5HO) Specified Ballast Dimming Constant Current (LED)											
Circuit Quantity (n/a with LED)	1 2†	One Two (2 Ballast minimum)											
Voltage	120 277 347 DV	120 Volts 277 Volts 347 Volts 120-277 Volts											
Options	EL PEL LEL CDF DL FS NAT PH PM TN UC MS	500 Minimum Lumen Battery Pack (90 Minutes; 32°F Starting Temp) 1100 Minimum Lumen Battery Pack (90 Minutes; 32°F Starting Temp) Integral 8.4W Emergency Battery Backup (4' length only, 45L max, 0°C minimum operating temperature, n/a with 347V) Captive Diffuser Fasteners Damp Location (Interior use NO gasketing) Single Fuse & Holder (one per circuit) Natorium Environment Option Phillips Head Fasteners Pendant Mount (Max. 3/8NPT stems by others; damp only) Twin Tube Night Light – 5/7/9 watts (120V only) stems by others; damp only Uplight Component (Pendant Mount only; n/a with 347 Voltage Option) Motion Sensor (2' and 4' LED only) (n/a with 347 Voltage Option)											
Accessories	CMB 9500 D-0552	Corner Mount Bracket (Must be ordered with DL Option) Torx® Screwdriver Torx Driver Bit (Required for CMB Option)											
TekLink	TL50 TL100	TL50 Control System (Click here for specifications) TL100 Control System (Click here for specifications)											
Controls Kit	< >	Factory Assigned Internal Code											



www.kenall.com | P: 800-4-Kenall | F: 262-891-9701 | 10200 55th Street Kenosha, Wisconsin 53144, USA

A brand of **legrand**

This product complies with the Buy American Act: manufactured in the United States with more than 50% of the component cost of US origin. It may be covered by patents found at www.kenall.com/patents. Content of specification sheets is subject to change; please consult www.kenall.com for current product details. ©2019 Kenall Mfg. Co.

MLHA8-113020



Catalog Information:

MLHA8-48-F-[FINISH]-PP-45L35K-DCC-DV-PEL-TL50

Date:01/27/2023
 Fixture Type:

B1

MILLENIUM STRETCH™

MLHA8 SERIES

PERFORMANCE

Length	Lamp Type	Initial Delivered Lumens		Input Power (W)	Drive Current (mA)	Estd. L70 LED Life (Hrs)
		@ 25°C	Efficacy (lm/W)			
2'	25L35K	2,379	95	25	100	150,000
	25L40K	2,536	101	25	100	150,000
	25L50K	2,536	101	25	100	150,000
4'	45L35K	4,758	97	49	100	150,000
	45L40K	5,072	104	49	100	150,000
	45L50K	5,072	104	49	100	150,000
	67L35K	7,284	100	73	75	150,000
	67L40K	7,765	106	73	75	150,000
	67L50K	7,765	106	73	75	150,000
	90L35K	9,252	94	98	100	150,000
	90L40K	9,864	101	98	100	150,000
	90L50K	9,864	101	98	100	150,000

Information above is valid for the recommended Type PP lens type and is subject to change without notice. Visit www.kenall.com for IES files and additional information.

Model: MLHA8-48-F-MW-PP-45L40K-DCC-DV

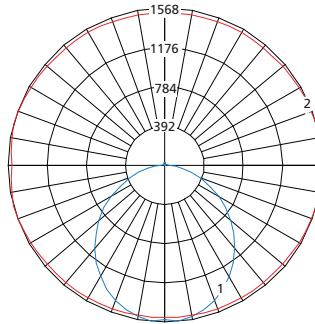

Maximum Candela = 1568 Located At Horizontal Angle = 15, Vertical Angle = 5

- 1 - Vertical Plane Through Horizontal Angles (15-195) (Through Max. Cd.)
- 2 - Horizontal Cone Through Vertical Angle (5) (Through Max. Cd.)

DIMENSIONAL DATA

CROSS SECTION/DETAILS

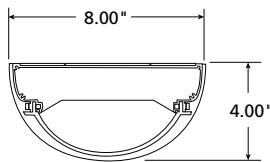

MOUNTING HOLES

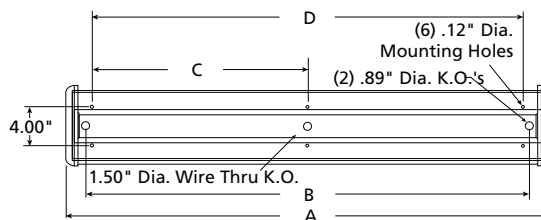

CORNER MOUNT BRACKET

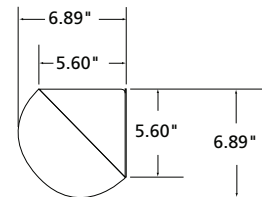

Nominal Two Foot Fixture Legend

LMP End Cap	A	B	C	D
T8 R	26.524	22.312	N/A	21.000
T8 F	25.308	22.312	N/A	21.000
T8 RV	28.632	22.312	N/A	21.000
T5 R	24.940	20.728	N/A	20.875
T5 F	23.724	20.728	N/A	20.875
T5 RV	27.048	20.728	N/A	20.875

Nominal Three Foot Fixture Legend

LMP End Cap	A	B	C	D
T8 R	38.524	34.312	16.500	33.000
T8 F	34.312	34.312	16.500	33.000
T8 RV	40.632	34.312	16.500	33.000
T5 R	36.751	32.540	16.344	32.688
T5 F	35.535	32.540	16.344	32.688
T5 RV	38.859	32.540	16.344	32.688

Nominal Four Foot Fixture Legend

LMP End Cap	A	B	C	D
T8/LED R	50.524	46.312	22.500	45.000
T8/LED F	49.308	46.312	22.500	45.000
T8/LED RV	52.632	46.312	22.500	45.000
T5 R	48.562	44.350	22.250	44.500
T5 F	47.346	44.350	22.250	44.500
T5 RV	50.670	44.350	22.250	44.500



www.kenall.com | P: 800-4-Kenall | F: 262-891-9701 | 10200 55th Street Kenosha, Wisconsin 53144, USA

A brand of **legrand**

This product complies with the Buy American Act: manufactured in the United States with more than 50% of the component cost of US origin. It may be covered by patents found at www.kenall.com/patents. Content of specification sheets is subject to change; please consult www.kenall.com for current product details. ©2019 Kenall Mfg. Co.

MLHA8-113020



Catalog Information:

MLHA8-48-F-[FINISH]-PP-45L35K-DCC-DV-PEL-TL50

Date: 01/27/2023

Fixture Type:

B1

MILLENIUM STRETCH™

MLHA8 SERIES

PRODUCT FEATURES:

- » Surface mount – wall or ceiling; nominal 8" x 24", 8" x 36" 8" x 48", 8" x 72", 8" x 96"
- » Extruded aluminum housing with decorative end caps
- » Peace of Mind Guarantee® against breakage
- » ADA compliant

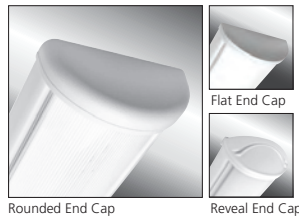

PROJECT INFORMATION

Job Name _____
 Fixture Type _____
 Catalog Number _____
 Approved by _____

SPECIFICATIONS

HOUSING: Marine grade aluminum. Extruded body with die-cast end caps. Housing, with end caps, post assembly TGIC polyester powder coat finished – 5-step pre-treatment. See Ordering Information for standard, optional, architectural and custom finishes.

REFLECTOR: Full reflector/wire cover – 92% reflectivity.

LENS: UV-stabilized, high impact extruded clear or pearlescent polycarbonate. Smooth exterior, linear prismatic interior. Nominal thickness .156". Lens securely positioned in body channels and end caps. Lens locked in place with tamper-resistant stainless steel Torx® with center pin fasteners and sealed with closed cell gaskets.

END CAPS: Marine grade die-cast aluminum. Three styles available: Flat, Rounded and Reveal. Conduit and "Wiremold™" ready" knockouts visible only from interior of end cap (Flat and Rounded styles only).

SOCKETS: Shock-resistant sockets with internal locking collar to ensure positive lamp retention.

HARDWARE: Stainless steel, tamper-resistant Torx fasteners secure lens in housing body's lens channel (four on 24", 36", and 48" housings; eight on 72" and 96" housings).

ELECTRICAL: LED: Available 3500K, 4000K and 5000K color temperatures, 82 CRI. 120-277VAC and 347VAC, 50/60Hz electrical input with serviceable high power factor electronic, constant-current driver (<20% THD, >0.95 PF). Standard 0-10V dimming with 1-100% range and dim-to-dark capabilities, maximum driver source of 330µA. Optional embedded microwave motion sensor (MS) has factory default settings of 20 minute time out, dims down to 30%. LE: Class P ballasts. Fluorescent electronic 120/277/347 and dual voltage ballasts high power factor.

INSTALLATION: Standard four-point (24" housing), six-point (36" and 48" housing) and twelve-point (72" and 96" housing) mounting required for Peace of Mind Guarantee®. LED product ambient temperature is -30°C to 40°C, unless otherwise noted.

TEKLINK™ TL50: An independent lighting control system embedded in the luminaire, featuring its own occupancy sensor, daylight harvesting and adjustable time-out/dimming settings.

TEKLINK™ TL100: Centralized, wired zonal occupancy and closed-loop daylight harvesting control system. TL100 controllers are standalone devices and ordered separately for luminaire. [Click here for specifications.](#)

PHOTOMETRICS: Photometry tested to the IESNA LM-79-08 standard by an ILAC/ISO17025 accredited laboratory. For additional photometric information, go to www.kenall.com.

WARRANTY: Limited ten (10) year warranty for LED Lamps.

LISTINGS: Luminaire is certified to UL standards by Intertek Testing Laboratories for non-IC and Wet Location installations. IP64 rating per IEC60598 – ceiling mount. Corner, horizontal wall and pendant mount installation – damp location only. ADA compliant.



ORDERING INFORMATION (Ex: MLHA8-48-F-MB-PP-45L40K-DCC-DV-FS-9500)

Model	Length	End Cap	Finish	Lens	Lamp Qty	Lamp Type	Ballast/Driver	Circuit Qty	Voltage	Options	Accessories	TekLink	Controls Kit
MLHA8													
Length	24 36 48 72 96												
End Caps	F R RV												
Finish	LG MB MW CC												
Lens	CP PP												
Lamp Quantity (Cross Section)	1 2 3												
Lamp Type													
Circuit Quantity (n/a with LED)													
Voltage													
Options													
Accessories													
TekLink													
Controls Kit													



www.kenall.com | P: 800-4-Kenall | F: 262-891-9701 | 10200 55th Street Kenosha, Wisconsin 53144, USA

A brand of **legrand**

This product complies with the Buy American Act: manufactured in the United States with more than 50% of the component cost of US origin. It may be covered by patents found at www.kenall.com/patents. Content of specification sheets is subject to change; please consult www.kenall.com for current product details. ©2019 Kenall Mfg. Co.

MLHA8-113020



Catalog Information:

MLHA8-48-F-[FINISH]-PP-45L35K-DCC-DV-PEL-TL50

Date: 01/27/2023
 Fixture Type:

B1A

MILLENIUM STRETCH™

MLHA8 SERIES

PERFORMANCE

Length	Lamp Type	Initial Delivered Lumens		Input Power (W)	Drive Current (mA)	Estd. L70 LED Life (Hrs)
		@ 25°C	Efficacy (lm/W)			
2'	25L35K	2,379	95	25	100	150,000
	25L40K	2,536	101	25	100	150,000
	25L50K	2,536	101	25	100	150,000
4'	45L35K	4,758	97	49	100	150,000
	45L40K	5,072	104	49	100	150,000
	45L50K	5,072	104	49	100	150,000
	67L35K	7,284	100	73	75	150,000
	67L40K	7,765	106	73	75	150,000
	67L50K	7,765	106	73	75	150,000
	90L35K	9,252	94	98	100	150,000
	90L40K	9,864	101	98	100	150,000
	90L50K	9,864	101	98	100	150,000

Information above is valid for the recommended Type PP lens type and is subject to change without notice. Visit www.kenall.com for IES files and additional information.

Model: MLHA8-48-F-MW-PP-45L40K-DCC-DV

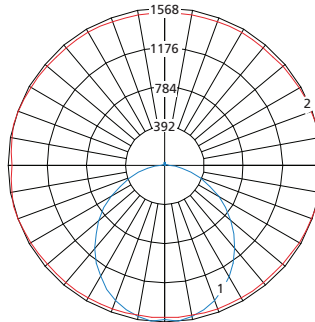

Maximum Candela = 1568 Located At Horizontal Angle = 15, Vertical Angle = 5

- 1 - Vertical Plane Through Horizontal Angles (15-195) (Through Max. Cd.)
- 2 - Horizontal Cone Through Vertical Angle (5) (Through Max. Cd.)

DIMENSIONAL DATA

CROSS SECTION/DETAILS

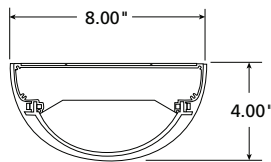

MOUNTING HOLES

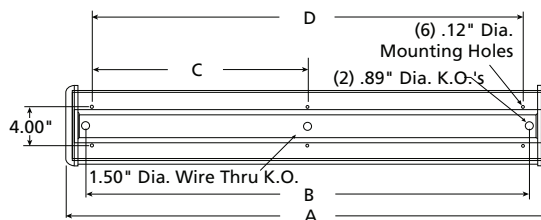

CORNER MOUNT BRACKET

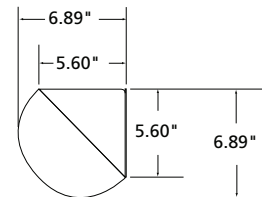

Nominal Two Foot Fixture Legend

LMP End Cap	A	B	C	D
T8 R	26.524	22.312	N/A	21.000
T8 F	25.308	22.312	N/A	21.000
T8 RV	28.632	22.312	N/A	21.000
T5 R	24.940	20.728	N/A	20.875
T5 F	23.724	20.728	N/A	20.875
T5 RV	27.048	20.728	N/A	20.875

Nominal Three Foot Fixture Legend

LMP End Cap	A	B	C	D
T8 R	38.524	34.312	16.500	33.000
T8 F	34.312	34.312	16.500	33.000
T8 RV	40.632	34.312	16.500	33.000
T5 R	36.751	32.540	16.344	32.688
T5 F	35.535	32.540	16.344	32.688
T5 RV	38.859	32.540	16.344	32.688

Nominal Four Foot Fixture Legend

LMP End Cap	A	B	C	D
T8/LED R	50.524	46.312	22.500	45.000
T8/LED F	49.308	46.312	22.500	45.000
T8/LED RV	52.632	46.312	22.500	45.000
T5 R	48.562	44.350	22.250	44.500
T5 F	47.346	44.350	22.250	44.500
T5 RV	50.670	44.350	22.250	44.500



www.kenall.com | P: 800-4-Kenall | F: 262-891-9701 | 10200 55th Street Kenosha, Wisconsin 53144, USA

This product complies with the Buy American Act: manufactured in the United States with more than 50% of the component cost of US origin. It may be covered by patents found at www.kenall.com/patents. Content of specification sheets is subject to change; please consult www.kenall.com for current product details. ©2019 Kenall Mfg. Co.

A brand of **legrand**

MLHA8-113020



Catalog Information:

MLHA8-48-F-[FINISH]-PP-45L35K-DCC-DV-PEL-TL50

Date: 01/27/2023

Fixture Type:

B1A

MILLENIUM STRETCH™

MLHA8 SERIES

PERFORMANCE

Length	Lamp Type	Initial Delivered Lumens		Input Power (W)	Drive Current (mA)	Estd. L70 LED Life (Hrs)
		@ 25°C	Efficacy (lm/W)			
2'	25L35K	2,379	95	25	100	150,000
	25L40K	2,536	101	25	100	150,000
	25L50K	2,536	101	25	100	150,000
4'	45L35K	4,758	97	49	100	150,000
	45L40K	5,072	104	49	100	150,000
	45L50K	5,072	104	49	100	150,000
	67L35K	7,284	100	73	75	150,000
	67L40K	7,765	106	73	75	150,000
	67L50K	7,765	106	73	75	150,000
	90L35K	9,252	94	98	100	150,000
	90L40K	9,864	101	98	100	150,000
	90L50K	9,864	101	98	100	150,000

Information above is valid for the recommended Type PP lens type and is subject to change without notice. Visit www.kenall.com for IES files and additional information.

Model: MLHA8-48-F-MW-PP-45L40K-DCC-DV

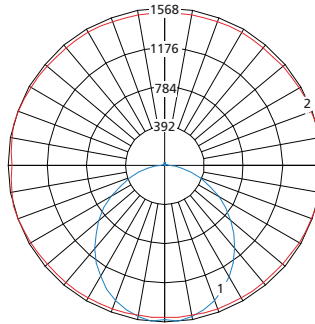

Maximum Candela = 1568 Located At Horizontal Angle = 15, Vertical Angle = 5

- 1 - Vertical Plane Through Horizontal Angles (15-195) (Through Max. Cd.)
- 2 - Horizontal Cone Through Vertical Angle (5) (Through Max. Cd.)

DIMENSIONAL DATA

CROSS SECTION/DETAILS

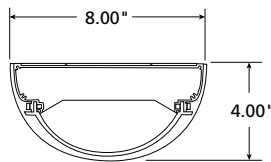

MOUNTING HOLES

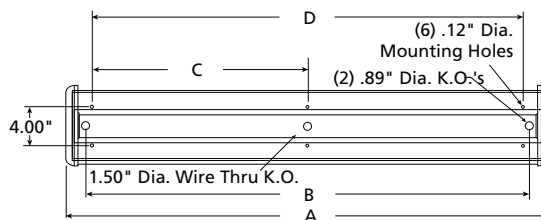

CORNER MOUNT BRACKET

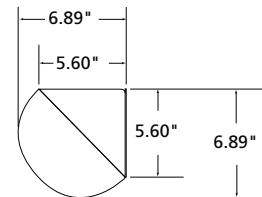

Nominal Two Foot Fixture Legend

LMP End Cap	A	B	C	D
T8 R	26.524	22.312	N/A	21.000
T8 F	25.308	22.312	N/A	21.000
T8 RV	28.632	22.312	N/A	21.000
T5 R	24.940	20.728	N/A	20.875
T5 F	23.724	20.728	N/A	20.875
T5 RV	27.048	20.728	N/A	20.875

Nominal Three Foot Fixture Legend

LMP End Cap	A	B	C	D
T8 R	38.524	34.312	16.500	33.000
T8 F	34.312	34.312	16.500	33.000
T8 RV	40.632	34.312	16.500	33.000
T5 R	36.751	32.540	16.344	32.688
T5 F	35.535	32.540	16.344	32.688
T5 RV	38.859	32.540	16.344	32.688

Nominal Four Foot Fixture Legend

LMP End Cap	A	B	C	D
T8/LED R	50.524	46.312	22.500	45.000
T8/LED F	49.308	46.312	22.500	45.000
T8/LED RV	52.632	46.312	22.500	45.000
T5 R	48.562	44.350	22.250	44.500
T5 F	47.346	44.350	22.250	44.500
T5 RV	50.670	44.350	22.250	44.500



www.kenall.com | P: 800-4-Kenall | F: 262-891-9701 | 10200 55th Street Kenosha, Wisconsin 53144, USA

This product complies with the Buy American Act: manufactured in the United States with more than 50% of the component cost of US origin. It may be covered by patents found at www.kenall.com/patents. Content of specification sheets is subject to change; please consult www.kenall.com for current product details. ©2019 Kenall Mfg. Co.

A brand of **legrand**

MLHA8-113020



Catalog Information:

MLHA8-36-F-FINISH-PP-33L35K-DCC-DV-SP

Date: 01/27/2023

Fixture Type:

B1B

MILLENIUM STRETCH™

MLHA8 SERIES

PRODUCT FEATURES:

- » Surface mount – wall or ceiling; nominal 8"×24", 8"×36" 8"×48", 8"×72", 8"×96"
- » Extruded aluminum housing with decorative end caps
- » Peace of Mind Guarantee® against breakage
- » ADA compliant

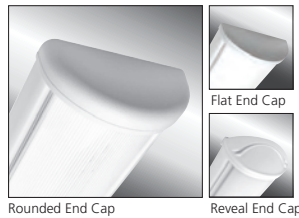

PROJECT INFORMATION

Job Name _____
 Fixture Type _____
 Catalog Number _____
 Approved by _____

SPECIFICATIONS

HOUSING: Marine grade aluminum. Extruded body with die-cast end caps. Housing, with end caps, post assembly TGIC polyester powder coat finished – 5-step pre-treatment. See Ordering Information for standard, optional, architectural and custom finishes.

REFLECTOR: Full reflector/wire cover – 92% reflectivity.

LENS: UV-stabilized, high impact extruded clear or pearlescent polycarbonate. Smooth exterior, linear prismatic interior. Nominal thickness .156". Lens securely positioned in body channels and end caps. Lens locked in place with tamper-resistant stainless steel Torx® with center pin fasteners and sealed with closed cell gaskets.

END CAPS: Marine grade die-cast aluminum. Three styles available: Flat, Rounded and Reveal. Conduit and "Wiremold™" ready" knockouts visible only from interior of end cap (Flat and Rounded styles only).

SOCKETS: Shock-resistant sockets with internal locking collar to ensure positive lamp retention.

HARDWARE: Stainless steel, tamper-resistant Torx fasteners secure lens in housing body's lens channel (four on 24", 36", and 48" housings; eight on 72" and 96" housings).

ELECTRICAL: LED: Available 3500K, 4000K and 5000K color temperatures, 82 CRI. 120-277VAC and 347VAC, 50/60Hz electrical input with serviceable high power factor electronic, constant-current driver (<20% THD, >0.95 PF). Standard 0-10V dimming with 1-100% range and dim-to-dark capabilities, maximum driver source of 330µA. Optional embedded microwave motion sensor (MS) has factory default settings of 20 minute time out, dims down to 30%. LE: Class P ballasts. Fluorescent electronic 120/277/347 and dual voltage ballasts high power factor.

INSTALLATION: Standard four-point (24" housing), six-point (36" and 48" housing) and twelve-point (72" and 96" housing) mounting required for Peace of Mind Guarantee®. LED product ambient temperature is -30°C to 40°C, unless otherwise noted.

TEKLINK™ TL50: An independent lighting control system embedded in the luminaire, featuring its own occupancy sensor, daylight harvesting and adjustable time-out/dimming settings.

TEKLINK™ TL100: Centralized, wired zonal occupancy and closed-loop daylight harvesting control system. TL100 controllers are standalone devices and ordered separately for luminaire. [Click here for specifications.](#)

PHOTOMETRICS: Photometry tested to the IESNA LM-79-08 standard by an ILAC/ISO17025 accredited laboratory. For additional photometric information, go to www.kenall.com.

WARRANTY: Limited ten (10) year warranty for LED Lamps.

LISTINGS: Luminaire is certified to UL standards by Intertek Testing Laboratories for non-IC and Wet Location installations. IP64 rating per IEC60598 – ceiling mount. Corner, horizontal wall and pendant mount installation – damp location only. ADA compliant.



ORDERING INFORMATION (Ex: MLHA8-48-F-MB-PP-45L40K-DCC-DV-FS-9500)

Model	Length	End Cap	Finish	Lens	Lamp Qty	Lamp Type	Ballast/Driver	Circuit Qty	Voltage	Options	Accessories	TekLink	Controls Kit
MLHA8													
Length	24 36 48 72 96	2' 3' 4' Two 3' (factory connected) Two 4' (factory connected)											
End Caps	F R RV	Flat Rounded Reveal											
Finish	LG MB MW CC	Light Gray Matte Black Matte White Custom Color (Consult Factory)											
Lens	CP PP	Clear Polycarbonate Pearlescent Polycarbonate											
Lamp Quantity (Cross Section)	1 2 3	One Two Three (T8 or T5 only)											
Lamp Type	25L35K 25L40K 25L50K	25 Watt 3500K LED 25 Watt 4000K LED 25 Watt 5000K LED											
Ballast/Driver Type	IS RS SB DCC	Instant Start Electronic <10% THD (T8) Rapid Start Electronic <10% THD (T8,T5,T5HO) Specified Ballast Dimming Constant Current (LED)											
Circuit Quantity (n/a with LED)	1 2†	One Two (2 Ballast minimum)											
Voltage	120 277 347 DV	120 Volts 277 Volts 347 Volts 120-277 Volts											
Options	EL PEL LEL CDF DL FS NAT PH PM TN UC MS	500 Minimum Lumen Battery Pack (90 Minutes; 32°F Starting Temp) 1100 Minimum Lumen Battery Pack (90 Minutes; 32°F Starting Temp) Integral 8.4W Emergency Battery Backup (4' length only, 45L max, 0°C minimum operating temperature, n/a with 347V) Captive Diffuser Fasteners Damp Location (Interior use NO gasketing) Single Fuse & Holder (one per circuit) Natorium Environment Option Phillips Head Fasteners Pendant Mount (Max. 3/8NPT stems by others; damp only) Twin Tube Night Light – 5/7/9 watts (120V only) stems by others; damp only Uplight Component (Pendant Mount only; n/a with 347 Voltage Option) Motion Sensor (2' and 4' LED only) (n/a with 347 Voltage Option)											
Accessories	CMB 9500 D-0552	Corner Mount Bracket (Must be ordered with DL Option) Torx® Screwdriver Torx Driver Bit (Required for CMB Option)											
TekLink	TL50 TL100	TL50 Control System (Click here for specifications) TL100 Control System (Click here for specifications)											
Controls Kit	< >	Factory Assigned Internal Code											



www.kenall.com | P: 800-4-Kenall | F: 262-891-9701 | 10200 55th Street Kenosha, Wisconsin 53144, USA

A brand of **legrand**

This product complies with the Buy American Act: manufactured in the United States with more than 50% of the component cost of US origin. It may be covered by patents found at www.kenall.com/patents. Content of specification sheets is subject to change; please consult www.kenall.com for current product details. ©2019 Kenall Mfg. Co.

MLHA8-113020



Catalog Information:

MLHA8-48-F-[FINISH]-PP-45L35K-DCC-DV-TL50

Date: 01/27/2023

Fixture Type:

B1C

Page: 1 of 2

MILLENIUM STRETCH™

MLHA8 SERIES

PERFORMANCE

Length	Lamp Type	Initial Delivered Lumens		Input Power (W)	Drive Current (mA)	Estd. L70 LED Life (Hrs)
		@ 25°C	Efficacy (lm/W)			
2'	25L35K	2,379	95	25	100	150,000
	25L40K	2,536	101	25	100	150,000
	25L50K	2,536	101	25	100	150,000
4'	45L35K	4,758	97	49	100	150,000
	45L40K	5,072	104	49	100	150,000
	45L50K	5,072	104	49	100	150,000
	67L35K	7,284	100	73	75	150,000
	67L40K	7,765	106	73	75	150,000
	67L50K	7,765	106	73	75	150,000
	90L35K	9,252	94	98	100	150,000
	90L40K	9,864	101	98	100	150,000
	90L50K	9,864	101	98	100	150,000

Information above is valid for the recommended Type PP lens type and is subject to change without notice. Visit www.kenall.com for IES files and additional information.

Model: MLHA8-48-F-MW-PP-45L40K-DCC-DV

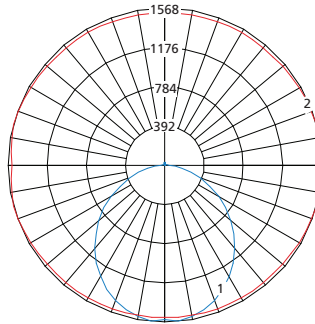

Maximum Candela = 1568 Located At Horizontal Angle = 15, Vertical Angle = 5

- 1 - Vertical Plane Through Horizontal Angles (15-195) (Through Max. Cd.)
- 2 - Horizontal Cone Through Vertical Angle (5) (Through Max. Cd.)

DIMENSIONAL DATA

CROSS SECTION/DETAILS

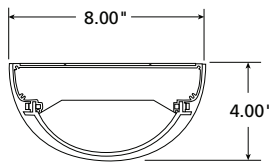

MOUNTING HOLES

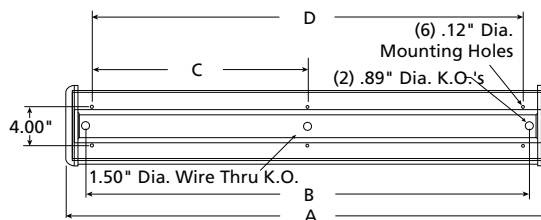

CORNER MOUNT BRACKET

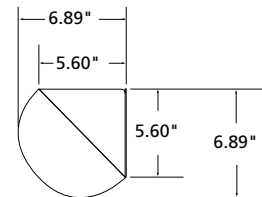

Nominal Two Foot Fixture Legend

LMP End Cap	A	B	C	D
T8 R	26.524	22.312	N/A	21.000
T8 F	25.308	22.312	N/A	21.000
T8 RV	28.632	22.312	N/A	21.000
T5 R	24.940	20.728	N/A	20.875
T5 F	23.724	20.728	N/A	20.875
T5 RV	27.048	20.728	N/A	20.875

Nominal Three Foot Fixture Legend

LMP End Cap	A	B	C	D
T8 R	38.524	34.312	16.500	33.000
T8 F	34.312	34.312	16.500	33.000
T8 RV	40.632	34.312	16.500	33.000
T5 R	36.751	32.540	16.344	32.688
T5 F	35.535	32.540	16.344	32.688
T5 RV	38.859	32.540	16.344	32.688

Nominal Four Foot Fixture Legend

LMP End Cap	A	B	C	D
T8/LED R	50.524	46.312	22.500	45.000
T8/LED F	49.308	46.312	22.500	45.000
T8/LED RV	52.632	46.312	22.500	45.000
T5 R	48.562	44.350	22.250	44.500
T5 F	47.346	44.350	22.250	44.500
T5 RV	50.670	44.350	22.250	44.500



www.kenall.com | P: 800-4-Kenall | F: 262-891-9701 | 10200 55th Street Kenosha, Wisconsin 53144, USA

This product complies with the Buy American Act: manufactured in the United States with more than 50% of the component cost of US origin. It may be covered by patents found at www.kenall.com/patents. Content of specification sheets is subject to change; please consult www.kenall.com for current product details. ©2019 Kenall Mfg. Co.

A brand of **legrand**

MLHA8-113020



Catalog Information:

MLHA8-48-F-[FINISH]-PP-45L35K-DCC-DV-TL50

Date: 01/27/2023

Fixture Type:

B1C

Catalog Number
Notes
Type

FEATURES & SPECIFICATIONS

INTENDED USE — The Lithonia Lighting JCBL LED Highbay is the affordable LED solution for users who prefer a luminaire with the look and feel of a round form factor. Gymnasiums, warehouses, packaging facilities and other industrial applications all benefit from JCBL's highly efficient design that saves over traditional sources. **Certain airborne contaminants can diminish the integrity of acrylic and/or polycarbonate.** [Click here for Acrylic-Polycarbonate Compatibility table for suitable uses.](#)

Certain airborne contaminants may adversely affect the functioning of LEDs and other electronic components, depending on various factors such as concentrations of the contaminants, ventilation, and temperature at the end-user location. [Click here for a list of substances that may not be suitable for interaction with LEDs and other electronic components.](#)

CONSTRUCTION — JCBL features an aluminum heat sink to maximize heat dissipation and extend the life of the luminaire by maximizing contact with the LEDs. A glass optical enclosure (IP65 rated) protects the LEDs from dust and other air contaminants. Reflector options including aluminum, prismatic acrylic and polycarbonate ship together and easily mount to the heatsink for quick installation.

OPTICS — Reflector and lens options provide maximum versatility and uniformity. Conical, flat or acrylic drop lenses offer enhanced aesthetics, minimize glare at lower mounting heights when paired with acrylic reflectors.

ELECTRICAL — Utilizes 90°C case temperature for maximum life at high temperatures. Less than 20% THD and PF >90. Luminaire Surge Protection Level: Designed to withstand up to 6kV/3kA per ANSI C82.77-5-2015 with MVOLT. Luminaire Surge Protection Level: Designed to withstand up to 10kV/5kA per ANSI C82.77-5-2015 with HVOLT. Input voltages include 120-277, 347/480 without the use of a step down transformer. 0-10V dimming standard for a dimming range of 100% to 10%. Suitable for 50/60Hz.

WIRELESS NETWORKING — Integrated Sensor (nLight Wired Networking): This sensor is nLight-enabled, meaning it has the ability to communicate over an nLight network. When wired, using CAT-5 cabling, with other nLight-enabled sensors, power packs, or WallPods, an nLight control zone is created. Once linked to a Gateway, directly or via a Bridge, the zone becomes capable of remote status monitoring and control via SensorView software.

Integrated Smart Sensor (nLight AIR Wireless Platform): The rSBOR sensor is nLight AIR enabled, meaning it has the ability to communicate over the wireless nLight control platform. It is available with an automatic dimming photocell, and either a digital PIR or dual technology occupancy sensor. It pairs to other luminaires and wall switches through our mobile app, CLAIRITY PRO, which allows for simple sensor adjustment.

INSTALLATION — Mounting options include steel hook & cord or 3/4" NPT threaded hub to accommodate stem or cast hook options.

LISTINGS — UL1598/C SA C22.2 250, Damp location listed. Suitable for use in ambient temperatures from -40°C up to 55°C.

DesignLights Consortium® (DLC) Premium qualified product and DLC qualified product. Not all versions of this product may be DLC Premium qualified or DLC qualified. Please check the DLC Qualified Products List at www.designlights.org/OPL to confirm which versions are qualified.

WARRANTY — 5-year limited warranty. This is the only warranty provided and no other statements in this specification sheet create any warranty of any kind. All other express and implied warranties are disclaimed. Complete warranty terms located at: www.acuitybrands.com/support/warranty/terms-and-conditions

Note: Actual performance may differ as a result of end-user environment and application.

All values are design or typical values, measured under laboratory conditions at 25 °C.

Specifications subject to change without notice.



LED Damp Rated High Bay

JCBL

9000, 12000, 15000, 18000,
24000, 30000 or 36000 lumens



A+ Capable Luminaire

This item is an A+ capable luminaire, which has been designed and tested to provide consistent color appearance and out-of-the-box control compatibility with simple commissioning.

- All configurations of this luminaire meet the Acuity Brands' specification for chromatic consistency
- This luminaire is part of an A+ Certified solution for nLight® control networks marked by a **shaded background***

To learn more about A+, visit www.acuitybrands.com/aplus.

*See ordering tree for details

JCBL LED Damp Rated High Bay

DIMENSIONS

All dimensions are in inches (centimeters) unless otherwise indicated.
Dimensions may vary with options or accessories.

Typical weight:

A cartoned luminaire weighs 23 lbs.;
unboxed it weighs 16 lbs.

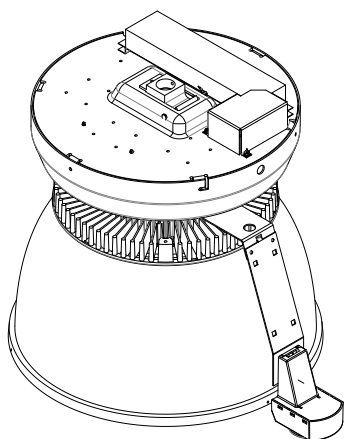
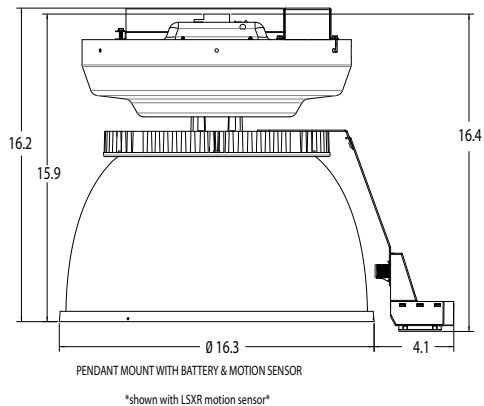
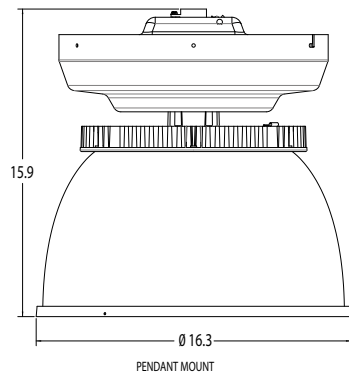

Lithonia-JCBL-JCBL-Round Bay-Round-LED-

INDUSTRIAL: One Lithonia Way, Conyers, GA 30012 Phone: 800-705-SERV (7378) techsupport-industrial@acuitybrands.com www.lithonia.com

© 2016-2022 Acuity Brands Lighting, Inc. All rights reserved. Rev. 05/05/22
Page 2 of 10



Catalog
Information:

JCBL-24000LM-ACFR-MVOLT-GZ10-35K-80CRI-PM-WG-DWHXD

Date:01/27/2023
Fixture Type:

B2

Page: 2 of 10

JCBL LED Damp Rated High Bay

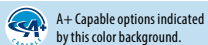

ORDERING INFORMATION Lead times will vary depending on options selected. Consult with your sales representative. **Example:** JCBL 24000LM DALR MVOLT GZ10 40K 80CRI SC6W DWHXD

JCBL Series	Lumens	Reflector	Lens ‡	Voltage	
JCBL	9000LM 9,000 lumens 12000LM 12,000 lumens 15000LM 15,000 lumens 18000LM 18,000 lumens 24000LM 24,000 lumens 30000LM 30,000 lumens 36000LM 36,000 lumens	DALR Diffuse aluminum SALR Specular aluminum ACFR Frosted acrylic ACCR Clear acrylic PLCR Clear polycarbonate	(blank) Open bottom For use with aluminum reflectors ALDRP Drop prismatic ALCON Conical ALFGL Flat prismatic	For use with acrylic and polycarbonate reflectors ACDRP Drop prismatic ACRCON Conical ACRGL Flat prismatic	MVOLT 120-277V HVOLT 347/480V 120 120V 208 208V 240 240V 277 277V 347 347V 480 480V

GZ10 Driver	Color temperature	Color rendering index	Mounting Configurations
GZ10 0-10V dimming ‡	30K 3000 K 35K 3500 K 40K 4000 K 50K 5000 K	70CRI 70 CRI 80CRI 80 CRI 90CRI 90 CRI	PM Pendant mount SC6W Steel hook & white 6' cord SC6PW Steel hook with white 6' cord and NEMA twist lock plug ‡ SC6PNW Steel hook with white 6' straight blade cordset ‡ SCS6G16WSTOW5D Steel hook with white 6' cord, 16/5, no plug, includes low voltage dimming wires ‡ SC12W Steel hook & 12' white cord SC12PW Steel hook with white 12' cord and NEMA twist lock plug ‡ SC12PNW Steel hook with white 12' straight blade cordset ‡ SCS12G16WSTOW5D Steel hook with white 12' cord, 16/5, no plug, includes low voltage dimming wires ‡

Options	Super Durable Finishes
<p>HOCS Hook, 6' RELOC® OCS ‡</p> <p>OCS 6' RELOC® OCS ‡</p> <p>E10WCP EM Self-diagnostics battery pack, 10W, constant power, certified in CA title 20 MAEDBS ‡</p> <p>BGTD Generator transfer device (120 or 277 only) ‡</p> <p>WG Wire guard for open bottom reflectors (ships separately) ‡</p> <p>FWG Full wire guard (ships separately)</p> <p>SCF120 Safety Cable 120"</p> <p>SCF240 Safety cable 240"</p> <p>Cordsets:</p> <p>C6W White 6' cord ‡</p> <p>C12W White 12' cord ‡</p> <p>C6PNW White 6' cord with straight blade plug ‡</p> <p>CS6G16WSTOW5D White 6' cord, 16/5, no plug, includes low voltage dimming wires ‡</p> <p>HK45S Safety hook, male, cast aluminum, factory installed ‡</p> <p>HC6W White 6' cord with male cast hook, no plug ‡</p> <p>HC6PW White 6' cord with male cast hook and NEMA twist lock plug ‡</p> <p>HC6PNW White 6' cord with male cast hook and straight blade cord ‡</p> <p>HC6P20W White 6' cord with male cast hook and 20-amp plug ‡</p> <p>HCS6G16WSTOW5D White 6' cord with male cast hook, 16/5, no plug, includes low voltage dimming wires ‡</p> <p>Controls:</p> <p>AO Adjustable output ‡</p> <p>LCOZU Aisle motion sensor, pre-wired</p> <p>LCHOSZU Aisle motion sensor, pre-wired; programmable dimming</p> <p>LCPZU Aisle motion sensor with photocell; pre-wired</p> <p>LAOZU 360° motion sensor, pre-wired</p> <p>LAHOSZU 360° motion sensor, pre-wired; programmable dimming</p> <p>LAPZU 360° motion sensor with photocell, pre-wired</p> <p>Controls:</p> <p>Individual Controls with Bluetooth Programming:</p> <p>LSXBTP 360° High Mount Occ Sensor, pre-wired; Bluetooth® ‡</p> <p>LSXBTPHL 360° High Mount Occ Sensor w/HL Default, pre-wired; Bluetooth® ‡</p> <p>LSXBTPADC 360° High Mount Occ Sensor w/ADC Default, pre-wired; Bluetooth® ‡</p> <p>LSXBTPANL 360° High Mount Occ Sensor w/ANL Default, pre-wired; Bluetooth® ‡</p> <p>nLight AIR Wireless Controls: ‡</p> <p>NLTAIR2 RKOA nLight AIR Generation 2 enabled 360° high mount motion sensor</p> <p>NLTAIR2 RKOB nLight AIR Generation 2 enabled 360° low mount motion sensor</p> <p>NLTAIR2 rPP20D nLight AIR Generation 2 dimming and switching module ‡</p> <p>NLTAIR2 rPP20DER nLight AIR Generation 2 dimming and switching module with emergency relay ‡</p> <p>nLight Wired Network Controls:</p> <p>NPP16D nLight® switching/dimming module ‡</p> <p>NPP16DER nLight® switching/dimming module with emergency relay ‡</p>	<p>DWHXD White</p> <p>DNAXD Natural aluminum</p> <p>DWHGXD Textured white</p> <p>DNATXD Textured natural aluminum</p> <p>DBLXD Black</p>

NOTE: ‡ indicates option chosen has ordering restrictions. Please reference ordering restrictions chart, page 4. Options are sorted alphanumerically.

Accessories and Notes next page.



Lithonia-JCBL-JCBL-Round Bay-Round-LED-



Catalog Information:

JCBL-24000LM-ACFR-MVOLT-GZ10-35K-80CRI-PM-WG-DWHXD

Date: 01/27/2023
Fixture Type:

B2

JCBL LED Damp Rated High Bay

Accessories: Order as separate catalog number.	
HK455	Safety hook, male, cast aluminum
JCBLHKF	Hook, female
JCBLSTEM12 XXX	Swivel stem kit, must specify finish.
JCBLSTEM24 XXX	Swivel stem kit, 24", must specify finish.
JCBLSTEM36 XXX	Swivel stem kit, 36", must specify finish.
WGJCBL	Wire guard for use with open bottom reflectors
FWGJCBL	Full wire guard

‡ Option Value Ordering Restrictions	
Option value	Restriction
ACRCON	Lensed fixtures are suitable for use in ambient temperatures up to 40°C.
Lens	Lensed fixtures are suitable for use in ambient temperatures up to 40°C.
AO	Not available with other controls.
BGTD	Only available with 120V or 277V. Not available with MVOLT or HVOLT. Not available with battery packs, plugs, XAD, XAD924, or NLTAIR2 RPP20DER.
C12W	PM option required.
C6W	PM option required.
C6PNW	PM option required. Not available with E10WCP, BGTD, NPP16DER or NLTAIR2 rPP20DER. Must specify voltage. Not available with MVOLT, HVOLT, 347V or 480V. Not available with battery packs.
CS6G16WSTOW5D	PM option required. Not available with E10WCP, BGTD, NPP16DER or NLTAIR2 rPP20DER.
E10WCP	Not available with 347V, 480V or HVOLT. Four conductor cordset ships standard when product is ordered with cord. Utilizes PS1055CP .
GZ10	If ordering a cord and dimming is required for your application, choose CS6G16WSTOW5D, SC12G16WSTOW5D, or HCS6G16WSTOW5D as your cord option.
HC6W	PM option required. Ships standard with HK455 option.
HC6PW	PM option required. Not available with E10WCP, BGTD, NPP16DER or NLTAIR2 rPP20DER. Must specify voltage. 120-277V utilizes a 15-amp plug, 347-480 utilizes a 20-amp plug (standard). Not available with battery packs. Ships standard with HK455 option.
HC6P20W	PM option required. Not available with E10WCP, BGTD, NPP16DER or NLTAIR2 rPP20DER. Must specify voltage. Not available with 347, 480, MVOLT or HVOLT. Not available with battery packs. Ships standard with HK455 option.
HC6PNW	PM option required. Not available with E10WCP, BGTD, NPP16DER or NLTAIR2 rPP20DER. Must specify voltage. Not available with MVOLT or HVOLT. 120-277V utilizes a 15-amp plug, 347-480 utilizes a 20-amp plug (standard). Not available with battery packs. Ships standard with HK455 option.
HCS6G16WSTOW5D	PM option required. Not available with E10WCP, BGTD, NPP16DER or NLTAIR2 rPP20DER. Ships standard with HK455 option.
HK455	PM option required.
HOCS	PM option required. Must specify voltage. Not available with MVOLT or HVOLT. Not available with cordsets. When reloc is selected fixture bears a dry location label. Fixture ships with OCS4C when ordered with battery pack. 120-277V utilizes a 15-amp plug, 347-480 utilizes a 20-amp plug (standard). Ships standard with HK455 option.
LSXBTP	Not able to order 9,000LM or 12,000LM with 347V, 480V, or HVOLT. 9,000LM and 12,000LM will not dim to off if ordered with LSXBTP, LSXBTPHL, LSXBTPADC or LSXBTPANL controls.
LSXBTPHL	Not able to order 9,000LM or 12,000LM with 347V, 480V, or HVOLT. 9,000LM and 12,000LM will not dim to off if ordered with LSXBTP, LSXBTPHL, LSXBTPADC or LSXBTPANL controls.
LSXBTPADC	Not able to order 9,000LM or 12,000LM with 347V, 480V, or HVOLT. 9,000LM and 12,000LM will not dim to off if ordered with LSXBTP, LSXBTPHL, LSXBTPADC or LSXBTPANL controls.
LSXBTPANL	Not able to order 9,000LM or 12,000LM with 347V, 480V, or HVOLT. 9,000LM and 12,000LM will not dim to off if ordered with LSXBTP, LSXBTPHL, LSXBTPADC or LSXBTPANL controls.
nLight AIR Wireless Controls	Normal luminaires (non-emergency) can be used as a normal power sensing device for nearby nLight AIR devices and luminaires with EM emergency options.
NLTAIR2 RPP20D	Not available with HVOLT, 347V, or 480V. Not available with battery or BGTD option.
NLTAIR2 RPP20DER	Not available with HVOLT, 347V, or 480V. Not available with battery or BGTD option.
NPP16D	Must specify voltage. Available with 120V-347V only. Not available with battery or BGTD option.
NPP16DER	Must specify voltage. Available with 120V-347V only. Not available with battery or BGTD option.
OCS	PM option required. Must specify voltage. Not available with MVOLT or HVOLT. Not available with cordsets. When reloc is selected fixture bears a dry location label. Fixture ships with OCS4C when ordered with battery pack. 120-277V utilizes a 15-amp plug, 347-480 utilizes a 20-amp plug (standard). Ships standard with HK455 option.
SC12PW	Not available with E10WCP, BGTD, NPP16DER or NLTAIR2 rPP20DER. Must specify voltage. Not available with MVOLT or HVOLT. 120-277V utilizes a 15-amp plug, 347-480 utilizes a 20-amp plug (standard). Not available with battery packs.
SC12PNW	Not available with E10WCP, BGTD, NPP16DER or NLTAIR2 rPP20DER. Must specify voltage. Not available with MVOLT, HVOLT, 347V or 480V. Not available with battery packs. If black cord is required, remove "W" from nomenclature. Example: SC12P.
SC6PW	Not available with E10WCP, BGTD, NPP16DER or NLTAIR2 rPP20DER. Must specify voltage. Not available with MVOLT or HVOLT. 120-277V utilizes a 15-amp plug, 347-480 utilizes a 20-amp plug (standard). Not available with battery packs.
SC6PNW	Not available with E10WCP, BGTD, NPP16DER or NLTAIR2 rPP20DER. Must specify voltage. Not available with MVOLT, HVOLT, 347V or 480V. If black cord is required, remove "W" from nomenclature. Example: SC6PN.
SCS6G16WSTOW5D	Not available with E10WCP, BGTD, NPP16DER or NLTAIR2 rPP20DER. Not available with battery packs. If black cord is required, remove "W" from nomenclature. Example: SCS6G16STOW5D.
SCS12G16WSTOW5D	Not available with E10WCP, BGTD, NPP16DER or NLTAIR2 rPP20DER. Not available with battery packs. If black cord is required, remove "W" from nomenclature. Example: SCS12G16STOW5D.



Lithonia-JCBL-JCBL-Round Bay-Round-LED-

INDUSTRIAL: One Lithonia Way, Conyers, GA 30012 Phone: 800-705-SERV (7378) techsupport-industrial@acuitybrands.com www.lithonia.com

© 2016-2022 Acuity Brands Lighting, Inc. All rights reserved. Rev. 05/05/22 Page 4 of 10



Catalog Information:

JCBL-24000LM-ACFR-MVOLT-GZ10-35K-80CRI-PM-WG-DWHXD

Date: 01/27/2023

Fixture Type:

B2

Page: 4 of 10

OPERATIONAL DATA

Lumen Package	Input Watts	Ambient Rating	Reflector	Lens	Delivered Lumens											
					3000K CCT, 70CRI	3500K CCT, 70CRI	4000K CCT, 70CRI	5000K CCT, 70CRI	3000K CCT, 80CRI	3500K CCT, 80CRI	4000K CCT, 80CRI	5000K CCT, 80CRI	3000K CCT, 90CRI	3500K CCT, 90CRI	4000K CCT, 90CRI	5000K CCT, 90CRI
9000LM	63	-40°F (-40°C) - 135°F (55°C)	ACCR	-	9628	10046	10186	10256	9418	9418	9558	10046	7814	8023	8163	8581
			ACFR	-	9602	10020	10159	10229	9394	9394	9533	10020	7793	8002	8141	8559
			DALR	-	8045	8395	8511	8569	7870	7870	7987	8395	6529	6704	6821	7170
			PLCR	-	8967	9357	9487	9552	8772	8772	8902	9357	7277	7472	7602	7992
			SALR	-	8811	9194	9322	9385	8619	8619	8747	9194	7151	7342	7470	7853
			ACCR	ACRCON	9014	9405	9536	9601	8818	8818	8948	9405	7315	7511	7642	8034
			ACFR	ACRCON	9069	9463	9594	9660	8872	8872	9003	9463	7360	7557	7689	8083
			PLCR	ACRCON	8422	8789	8911	8972	8239	8239	8361	8789	6836	7019	7141	7507
			ACCR	ACDRDP	8900	9287	9416	9480	8706	8706	8835	9287	7223	7416	7545	7932
			ACFR	ACDRDP	9082	9477	9608	9674	8884	8884	9016	9477	7371	7568	7700	8095
			PLCR	ACDRDP	8350	8713	8834	8894	8168	8168	8289	8713	6777	6958	7079	7442
			ACCR	ACRFLG	9042	9435	9566	9632	8845	8845	8976	9435	7338	7535	7666	8059
			ACFR	ACRFLG	9102	9498	9630	9696	8904	8904	9036	9498	7387	7585	7717	8113
			PLCR	ACRFLG	8378	8742	8864	8924	8196	8196	8317	8742	6800	6982	7103	7467
			DALR	ALCON	7787	7895	7949	7462	7300	7300	7408	7787	6056	6219	6327	6651
			SALR	ALCON	8529	8648	8707	8174	7996	7996	8115	8529	6634	6812	6930	7286
			DALR	ALDRP	7778	7886	7940	7453	7291	7291	7399	7778	6049	6211	6319	6643
			SALR	ALDRP	8580	8699	8758	8222	8043	8043	8162	8580	6673	6852	6971	7328
			DALR	ALFGL	7613	7719	7772	7296	7138	7138	7243	7613	5922	6080	6186	6503
			SALR	ALFGL	8564	8683	8743	8207	8029	8029	8148	8564	6661	6839	6958	7315
12000LM	84	-40°F (-40°C) - 135°F (55°C)	ACCR	-	12418	12958	13138	13228	12148	12148	12328	12958	10079	10349	10529	11069
			ACFR	-	12386	12924	13104	13193	12116	12116	12296	12924	10052	10321	10501	11039
			DALR	-	10377	10828	10978	11053	10151	10151	10301	10828	8422	8647	8798	9249
			PLCR	-	11566	12069	12236	12320	11314	11314	11482	12069	9387	9638	9806	10309
			SALR	-	11365	11859	12023	12106	11118	11118	11282	11859	9223	9471	9635	10129
			ACCR	ACRCON	11626	12132	12300	12384	11373	11373	11542	12132	9436	9688	9857	10362
			ACFR	ACRCON	11697	12206	12375	12460	11443	11443	11613	12206	9493	9748	9917	10426
			PLCR	ACRCON	10864	11336	11493	11572	10628	10628	10785	11336	8817	9053	9211	9683
			ACCR	ACDRDP	11479	11978	12145	12228	11230	11230	11396	11978	9316	9566	9732	10231
			ACFR	ACDRDP	11714	12223	12393	12478	11459	11459	11629	12223	9507	9762	9932	10441
			PLCR	ACDRDP	10770	11238	11394	11472	10536	10536	10692	11238	8741	8975	9131	9599
			ACCR	ACRFLG	11663	12170	12339	12423	11409	11409	11578	12170	9465	9719	9888	10395
			ACFR	ACRFLG	11740	12251	12421	12506	11485	11485	11655	12251	9528	9784	9954	10464
			PLCR	ACRFLG	10806	11276	11433	11511	10572	10572	10728	11276	8770	9005	9162	9632
			DALR	ALCON	10044	10183	10253	9625	9416	9416	9555	10044	7812	8021	8160	8579
			SALR	ALCON	11002	11155	11231	10543	10314	10314	10467	11002	8557	8786	8939	9397
			DALR	ALDRP	10032	10171	10241	9614	9405	9405	9544	10032	7803	8012	8151	8569
			SALR	ALDRP	11066	11220	11297	10605	10375	10375	10528	11066	8607	8838	8991	9452
			DALR	ALFGL	9820	9956	10025	9411	9206	9206	9343	9820	7638	7842	7979	8388
			SALR	ALFGL	11047	11200	11277	10586	10356	10356	10510	11047	8592	8822	8975	9436



Lithonia-JCBL-JCBL-Round Bay-Round-LED-



Catalog Information:

JCBL-24000LM-ACFR-MVOLT-GZ10-35K-80CRI-PM-WG-DWHXD

Date: 01/27/2023

Fixture Type:

B2

JCBL LED Damp Rated High Bay

OPERATIONAL DATA (continued)

Lumen Package	Input Watts	Ambient Rating	Reflector	Lens	Delivered Lumens											
					3000K CCT, 70CRI	3500K CCT, 70CRI	4000K CCT, 70CRI	5000K CCT, 70CRI	3000K CCT, 80CRI	3500K CCT, 80CRI	4000K CCT, 80CRI	5000K CCT, 80CRI	3000K CCT, 90CRI	3500K CCT, 90CRI	4000K CCT, 90CRI	5000K CCT, 90CRI
15000LM	103	-40°F (-40°C) - 135°F (55°C)	ACCR	-	14899	15547	15763	15871	14575	14575	14791	15547	12092	12416	12632	13280
			ACFR	-	14860	15506	15721	15829	14537	14537	14752	15506	12060	12383	12598	13244
			DALR	-	12449	12991	13171	13261	12179	12179	12359	12991	10104	10375	10555	11096
			PLCR	-	13876	14479	14681	14781	13575	13575	13776	14479	11262	11563	11765	12368
			SALR	-	13635	14228	14425	14524	13338	13338	13536	14228	11066	11362	11560	12153
			ACCR	ACRCON	13948	14555	14757	14858	13645	13645	13847	14555	11321	11624	11826	12432
			ACFR	ACRCON	14034	14644	14847	14949	13729	13729	13932	14644	11390	11695	11898	12508
			PLCR	ACRCON	13034	13600	13789	13884	12750	12750	12939	13600	10578	10861	11050	11617
			ACCR	ACDRP	13772	14371	14571	14670	13473	13473	13672	14371	11177	11477	11676	12275
			ACFR	ACDRP	14054	14665	14869	14971	13749	13749	13952	14665	11406	11712	11915	12526
			PLCR	ACDRP	12921	13483	13670	13764	12640	12640	12828	13483	10487	10768	10955	11517
			ACCR	ACRFL	13992	14601	14804	14905	13688	13688	13891	14601	11356	11660	11863	12471
			ACFR	ACRFL	14085	14698	14902	15004	13779	13779	13983	14698	11432	11738	11942	12554
			PLCR	ACRFL	12965	13529	13717	13811	12683	12683	12871	13529	10522	10804	10992	11556
			DALR	ALCON	12050	12217	12301	11548	11297	11297	11464	12050	9372	9623	9791	10293
			SALR	ALCON	13199	13383	13474	12649	12374	12374	12558	13199	10266	10541	10725	11274
			DALR	ALDRP	12036	12203	12286	11534	11283	11283	11451	12036	9361	9612	9779	10281
			SALR	ALDRP	13277	13461	13553	12724	12447	12447	12631	13277	10326	10603	10787	11341
			DALR	ALFGL	11782	11945	12027	11291	11045	11045	11209	11782	9164	9409	9573	10064
			SALR	ALFGL	13253	13437	13529	12701	12425	12425	12609	13253	10308	10584	10768	11320
18000LM	125	-40°F (-40°C) - 135°F (55°C)	ACCR	-	18253	19047	19311	19443	17856	17856	18121	19047	14814	15211	15475	16269
			ACFR	-	18205	18996	19260	19392	17809	17809	18073	18996	14775	15171	15434	16226
			DALR	-	15252	15915	16136	16247	14920	14920	15141	15915	12378	12710	12931	13594
			PLCR	-	17000	17739	17985	18109	16630	16630	16877	17739	13797	14167	14413	15152
			SALR	-	16704	17430	17672	17794	16341	16341	16583	17430	13557	13920	14162	14888
			ACCR	ACRCON	17088	17831	18079	18203	16717	16717	16965	17831	13869	14240	14488	15231
			ACFR	ACRCON	17193	17941	18190	18314	16819	16819	17068	17941	13954	14328	14577	15324
			PLCR	ACRCON	15968	16662	16894	17009	15621	15621	15852	16662	12959	13307	13538	14232
			ACCR	ACDRP	16873	17606	17851	17973	16506	16506	16750	17606	13694	14060	14305	15039
			ACFR	ACDRP	17218	17966	18216	18341	16844	16844	17093	17966	13974	14348	14598	15346
			PLCR	ACDRP	15830	16518	16748	16862	15486	15486	15715	16518	12847	13192	13421	14109
			ACCR	ACRFL	17142	17888	18136	18260	16770	16770	17018	17888	13913	14285	14534	15279
			ACFR	ACRFL	17256	18006	18257	18382	16881	16881	17131	18006	14005	14380	14630	15381
			PLCR	ACRFL	15884	16574	16805	16920	15538	15538	15769	16574	12891	13236	13467	14157
			DALR	ALCON	14762	14967	15070	14147	13840	13840	14045	14762	11482	11789	11995	12610
			SALR	ALCON	16171	16395	16508	15497	15160	15160	15385	16171	12577	12914	13139	13813
			DALR	ALDRP	14745	14950	15052	14131	13824	13824	14028	14745	11468	11776	11980	12595
			SALR	ALDRP	16266	16492	16605	15588	15249	15249	15475	16266	12651	12990	13216	13894
			DALR	ALFGL	14434	14634	14735	13833	13532	13532	13732	14434	11226	11527	11728	12329
			SALR	ALFGL	16237	16462	16575	15560	15222	15222	15447	16237	12628	12967	13192	13869



Lithonia-JCBL-JCBL-Round Bay-Round-LED-

INDUSTRIAL: One Lithonia Way, Conyers, GA 30012 Phone: 800-705-SERV (7378) techsupport-industrial@acuitybrands.com www.lithonia.com © 2016-2022 Acuity Brands Lighting, Inc. All rights reserved. Rev. 05/05/22 Page 6 of 10



Catalog Information:

JCBL-24000LM-ACFR-MVOLT-GZ10-35K-80CRI-PM-WG-DWHXD

Date: 01/27/2023

Fixture Type:

B2

Page: 6 of 10

JCBL LED Damp Rated High Bay

OPERATIONAL DATA (continued)

Lumen Package	Input Watts	Ambient Rating	Reflector	Lens	Delivered Lumens											
					3000K CCT, 70CRI	3500K CCT, 70CRI	4000K CCT, 70CRI	5000K CCT, 70CRI	3000K CCT, 80CRI	3500K CCT, 80CRI	4000K CCT, 80CRI	5000K CCT, 80CRI	3000K CCT, 90CRI	3500K CCT, 90CRI	4000K CCT, 90CRI	5000K CCT, 90CRI
24000LM	160	-40°F (-40°C) - 135°F (55°C)	ACCR	-	23693	24723	25066	25238	23178	23178	23521	24723	19229	19744	20087	21118
			ACFR	-	23630	24658	25000	25171	23117	23117	23459	24658	19178	19692	20034	21062
			DALR	-	19797	20658	20945	21089	19367	19367	19654	20658	16067	16498	16785	17646
			PLCR	-	22066	23026	23346	23505	21587	21587	21906	23026	17909	18389	18708	19668
			SALR	-	21682	22625	22939	23096	21211	21211	21525	22625	17597	18069	18383	19326
			ACCR	ACRCON	22181	23146	23467	23628	21699	21699	22021	23146	18002	18484	18806	19770
			ACFR	ACRCON	22317	23287	23611	23773	21832	21832	22155	23287	18112	18598	18921	19891
			PLCR	ACRCON	20727	21628	21928	22078	20276	20276	20577	21628	16822	17272	17573	18474
			ACCR	ACDRDP	21901	22853	23171	23329	21425	21425	21742	22853	17775	18251	18568	19520
			ACFR	ACDRDP	22349	23321	23645	23807	21863	21863	22187	23321	18138	18624	18948	19920
			PLCR	ACDRDP	20548	21441	21739	21888	20101	20101	20399	21441	16676	17123	17421	18314
			ACCR	ACRFLG	22251	23219	23541	23702	21767	21767	22090	23219	18059	18543	18865	19833
			ACFR	ACRFLG	22399	23373	23697	23860	21912	21912	22237	23373	18179	18666	18990	19964
			PLCR	ACRFLG	20617	21514	21813	21962	20169	20169	20468	21514	16733	17181	17480	18376
			DALR	ALCON	19162	19428	19561	18364	17964	17964	18231	19162	14904	15303	15569	16368
			SALR	ALCON	20990	21282	21427	20115	19678	19678	19970	20990	16326	16763	17054	17929
			DALR	ALDRP	19140	19405	19538	18342	17943	17943	18209	19140	14886	15285	15551	16348
			SALR	ALDRP	21113	21407	21553	20234	19794	19794	20087	21113	16421	16861	17155	18034
			DALR	ALFGL	18736	18996	19126	17955	17565	17565	17825	18736	14572	14962	15223	16003
			SALR	ALFGL	21076	21368	21515	20197	19758	19758	20051	21076	16392	16831	17124	18002
30000LM	204	-40°F (-40°C) - 135°F (55°C)	ACCR	-	29714	31006	31437	31652	29068	29068	29499	31006	24116	24762	25193	26484
			ACFR	-	29636	30924	31354	31569	28992	28992	29421	30924	24052	24696	25126	26414
			DALR	-	24829	25908	26268	26448	24289	24289	24649	25908	20151	20691	21051	22130
			PLCR	-	27674	28878	29279	29479	27073	27073	27474	28878	22460	23062	23463	24666
			SALR	-	27193	28375	28769	28966	26602	26602	26996	28375	22070	22661	23055	24237
			ACCR	ACRCON	27819	29028	29431	29633	27214	27214	27617	29028	22577	23182	23585	24795
			ACFR	ACRCON	27989	29206	29611	29814	27380	27380	27786	29206	22716	23324	23730	24947
			PLCR	ACRCON	25994	27124	27501	27690	25429	25429	25806	27124	21097	21662	22039	23169
			ACCR	ACDRDP	27467	28661	29059	29258	26870	26870	27268	28661	22292	22889	23287	24482
			ACFR	ACDRDP	28029	29248	29654	29857	27420	27420	27826	29248	22748	23358	23764	24982
			PLCR	ACDRDP	25770	26890	27264	27450	25209	25209	25583	26890	20915	21475	21848	22969
			ACCR	ACRFLG	27906	29119	29524	29726	27299	27299	27704	29119	22648	23255	23660	24873
			ACFR	ACRFLG	28092	29313	29720	29924	27481	27481	27888	29313	22799	23410	23817	25038
			PLCR	ACRFLG	25857	26982	27356	27544	25295	25295	25670	26982	20986	21548	21922	23047
			DALR	ALCON	24032	24366	24533	23031	22530	22530	22864	24032	18692	19192	19526	20527
			SALR	ALCON	26325	26690	26873	25228	24679	24679	25045	26325	20475	21023	21389	22486
			DALR	ALDRP	24004	24337	24504	23004	22504	22504	22837	24004	18670	19170	19503	20503
			SALR	ALDRP	26479	26847	27031	25376	24824	24824	25192	26479	20595	21147	21514	22618
			DALR	ALFGL	23497	23823	23987	22518	22029	22029	22355	23497	18276	18765	19091	20070
			SALR	ALFGL	26432	26799	26982	25330	24780	24780	25147	26432	20558	21109	21476	22577



Lithonia-JCBL-JCBL-Round Bay-Round-LED-



Catalog Information:

JCBL-24000LM-ACFR-MVOLT-GZ10-35K-80CRI-PM-WG-DWHXD

Date: 01/27/2023

Fixture Type:

B2

JCBL LED Damp Rated High Bay

OPERATIONAL DATA (continued)

Lumen Package	Input Watts	Ambient Rating	Reflector	Lens	Delivered Lumens											
					3000K CCT, 70CRI	3500K CCT, 70CRI	4000K CCT, 70CRI	5000K CCT, 70CRI	3000K CCT, 80CRI	3500K CCT, 80CRI	4000K CCT, 80CRI	5000K CCT, 80CRI	3000K CCT, 90CRI	3500K CCT, 90CRI	4000K CCT, 90CRI	5000K CCT, 90CRI
36000LM	249	-40°F (-40°C) - 135°F (45°C)	ACCR	-	34589	36093	36594	36845	33837	33837	34338	36093	28072	28824	29325	30829
			ACFR	-	34497	35997	36497	36747	33747	33747	34247	35997	27998	28748	29248	30748
			DALR	-	28902	30158	30577	30787	28274	28274	28692	30158	23457	24085	24504	25760
			PLCR	-	32214	33615	34082	34315	31514	31514	31981	33615	26145	26845	27312	28713
			SALR	-	31654	33030	33489	33718	30966	30966	31424	33030	25690	26378	26837	28213
			ACCR	ACRCON	32382	33790	34259	34494	31678	31678	32147	33790	26281	26985	27454	28862
			ACFR	ACRCON	32580	33997	34469	34705	31872	31872	32344	33997	26442	27150	27622	29039
			PLCR	ACRCON	30259	31574	32013	32232	29601	29601	30039	31574	24558	25215	25654	26970
			ACCR	ACDRP	31973	33363	33826	34058	31278	31278	31741	33363	25949	26644	27107	28498
			ACFR	ACDRP	32627	34046	34519	34755	31918	31918	32391	34046	26480	27189	27662	29081
			PLCR	ACDRP	29997	31301	31736	31953	29345	29345	29780	31301	24345	24998	25432	26737
			ACCR	ACRFL	32484	33896	34367	34602	31778	31778	32249	33896	26364	27070	27541	28953
			ACFR	ACRFL	32700	34122	34595	34832	31989	31989	32463	34122	26539	27250	27724	29145
			PLCR	ACRFL	30099	31408	31844	32062	29445	29445	29881	31408	24428	25083	25519	26827
			DALR	ALCON	27974	28363	28557	26809	26226	26226	26614	27974	21758	22341	22729	23895
			SALR	ALCON	30643	31069	31281	29366	28728	28728	29153	30643	23833	24472	24897	26174
			DALR	ALDRP	27941	28329	28524	26777	26195	26195	26583	27941	21732	22314	22702	23867
			SALR	ALDRP	30823	31251	31465	29539	28896	28896	29325	30823	23973	24615	25044	26328
			DALR	ALFGL	27352	27732	27922	26212	25642	25642	26022	27352	21274	21843	22223	23363
			SALR	ALFGL	30768	31195	31409	29486	28845	28845	29272	30768	23930	24571	24999	26281

UPLIGHT PERCENTAGES (*Based on 24,000LM 40K 80CRI)

Reflector Option	Flat Lens	Conical Lens	Drop Lens	L/Lens
ACFR	18.0%	17.0%	17.4%	13.1%
ACCR	7.2%	5.8%	7.4%	2.7%
PLCR	6.6%	5.0%	6.8%	2.2%
SALR	0.1%	0.1%	1.7%	0.0%
DALR	0.1%	0.1%	1.8%	0.1%

AO CHART

Lumen Package	AO Position	% Lumen Output		% Wattage		
		AO Position	% Lumen Output	% Wattage	% Wattage	
9000LM	1	37%	38%			
	2	50%	49%			
	3	63%	62%			
	4	76%	74%			
	5	89%	87%			
	6	100%	100%			
	7	100%	100%			
	8	100%	100%			
12000LM	1	38%	36%			
	2	51%	48%			
	3	64%	60%			
	4	76%	74%			
	5	89%	87%			
	6	100%	100%			
	7	100%	100%			
	8	100%	100%			
18000LM	1	38%	36%			
	2	51%	48%			
	3	64%	61%			
	4	77%	74%			
18000LM	5	89%	87%			
	6	100%	100%			
	7	100%	100%			
	8	100%	100%			
	24000LM	1	38%	36%		
		2	51%	48%		
		3	64%	61%		
		4	77%	74%		
5		89%	87%			
6		100%	100%			
7		100%	100%			
8		100%	100%			
30000LM	1	38%	35%			
	2	51%	48%			
	3	64%	61%			
	4	77%	74%			
	5	89%	87%			
	6	100%	100%			
	7	100%	100%			
	8	100%	100%			
30000LM	1	39%	37%			
	2	52%	49%			
	3	65%	62%			
	4	77%	75%			
	5	89%	88%			
	6	100%	100%			
	7	100%	100%			
	8	100%	100%			
36000LM	1	39%	36%			
	2	53%	49%			
	3	66%	61%			
	4	78%	74%			
	5	90%	87%			
	6	100%	100%			
	7	100%	100%			
	8	100%	100%			



Lithonia-JCBL-JCBL-Round Bay-Round-LED-

INDUSTRIAL: One Lithonia Way, Conyers, GA 30012 Phone: 800-705-SERV (7378) techsupport-industrial@acuitybrands.com www.lithonia.com

© 2016-2022 Acuity Brands Lighting, Inc. All rights reserved. Rev. 05/05/22

Page 8 of 10



Catalog Information:

JCBL-24000LM-ACFR-MVOLT-GZ10-35K-80CRI-PM-WG-DWHXD

Date: 01/27/2023

Fixture Type:

B2

Page: 8 of 10

JCBL LED Damp Rated High Bay

OPERATIONAL DATA (continued)

LUMEN MAINTENANCE TABLE

Lumen Package	25,000	35,000	50,000	60,000
9000LM	0.97	0.96	0.95	0.94
12000LM	0.97	0.96	0.95	0.94
15000LM	0.96	0.95	0.94	0.93
18000LM	0.96	0.95	0.94	0.93
24000LM	0.96	0.95	0.93	0.93
30000LM	0.95	0.94	0.93	0.92
36000LM	0.95	0.93	0.91	0.90

LAT TABLE VS. AMBIENT TEMPERATURE (C)

Lumen Package	25	30	35	40	45	50	55
9000LM	1.00	1.00	0.99	0.99	0.98	0.98	0.97
12000LM	1.00	1.00	0.99	0.98	0.98	0.97	0.97
15000LM	1.00	0.99	0.99	0.98	0.98	0.97	0.96
18000LM	1.00	0.98	0.98	0.97	0.96	0.96	0.95
24000LM	1.00	0.99	0.99	0.98	0.97	0.97	0.96
30000LM	1.00	0.99	0.99	0.98	0.97	0.97	
36000LM	1.00	0.99	0.99	0.98			

REFLECTORS AND LENSES



Aluminum reflector
Available specular (SALR) or diffuse (DALR)



Acrylic frosted reflector (ACFR)



Clear acrylic (ACCR) or polycarbonate reflector (PLCR)



Acrylic drop lens (ACDRP)



Flat prismatic lens (ALFGL)



Conical lens (ALCON)

OPTIONS AND ACCESSORIES



Full Wire Guard (FWG)
All dimensions are in inches.

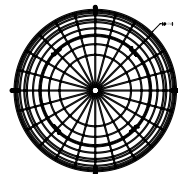

Wire Guard (WG)

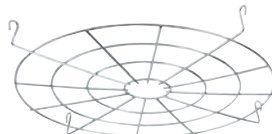

Safety Cable (JCBLSC120 or JCBLSC240)



Cast Hook Female (JCBLHKF)



Lithonia-JCBL-JCBL-Round Bay-Round-LED-

INDUSTRIAL: One Lithonia Way, Conyers, GA 30012 Phone: 800-705-SERV (7378) techsupport-industrial@acuitybrands.com www.lithonia.com

© 2016-2022 Acuity Brands Lighting, Inc. All rights reserved. Rev. 05/05/22
Page 9 of 10



Catalog
Information:

JCBL-24000LM-ACFR-MVOLT-GZ10-35K-80CRI-PM-WG-DWHXD

Date:01/27/2023

Fixture Type:

B2

Page: 9 of 10

SELECTIONS BELOW WILL EXTEND ORDER LEAD TIME. CONSULT YOUR SALES REPRESENTATIVE FOR DETAILS.

SINGLE RELAY

ORDERING INFORMATION

Example: LAHOSZU

Series	Lens option	Dimming/Photocell	Max. dim level	Min. dim level	Temp/Humidity	Default occupancy time delay
L LSXR passive infrared indoor occupancy sensor	A High mount, 360°	O None ¹	0 10 VDC	5 Minimum dim level of ballast	Z None	I 30 sec
	B Low mount, 360°	H High/low occupancy operation	9 9 VDC	1 1 VDC	T Low temperature ²	D 2.5 min
	C High mount aisleway	P Switching photocell (on/off) ¹	8 8 VDC	2 2 VDC	3 3 VDC	X 5.0 min
		M Dimming and switching photocell	7 7 VDC	4 4 VDC	5 5 VDC	R 7.5 min
		G Dimming and switching photocell with high/low occupancy operation		6 6 VDC		U 10.0 min (with minimum 15 minute on time)
						V 15.0 min
						W 20.0 min
				Y 30.0 min		

Notes

- 1 Max and min dim levels not applicable with this option.
- 2 Ambient temperature rating of -4°F (-20°C) to 131°F (55°C).

Example: LENS 50 J100

Replacement lenses: Order as separate catalog number.		
Series	Lens type	Package quantity
LENS	6 High mount 360°	[blank] Single Lens
	10 Low mount 360°	J10 10-pack
	50 High mount aisleway	J100 100-pack

Bluetooth Sensor

Model	Default Operation	LSXR Equivalent	Occupancy Time Delay	Photocell Mode	Photocell Set-point	Low Trim	High Trim	Dim to Off Time Delay
LSXBTP	On/Off Occupancy Only Disabled	LSXR 10 LT or LBO0STU	10 minutes	Disabled	n/a	n/a	100%	Disabled
LSXBPHL	Occupancy w/ 0-10V Dimming (High/Low/Off)	LSXR 10 HL LT or LBHOSTU	10 minutes	Disabled	n/a	10%	100%	2.5 minutes
LSXBTPADC	Occupancy w/ Dim & Switch Photocell	LSXR 10 ADC LT or LBMOSTU	10 minutes	On/Off & Auto Dim	50 fc	10%	100%	0 seconds
LSXBTPANL	Dim & Switch Photocell with High/Low Occupancy Operation	LSXR 10 ANL LT or LBGOSTU	10 minutes	On/Off & Auto Dim	50 fc	10%	100%	Stay Dim/Never Off

SBG BTP Wireless Sensor: [Web Page](#) | [Presentation](#)

VLP Mobile App: [Web Page](#) | [Sell Sheet](#) | [FAQ](#) | [User Guide](#) | [Configuration Video](#)

PHOTOMETRICS

See www.lithonia.com.



Lithonia-JCBL-JCBL-Round Bay-Round-LED-



Catalog Information:

JCBL-24000LM-ACFR-MVOLT-GZ10-35K-80CRI-PM-WG-DWHXD

Date:01/27/2023
Fixture Type:

B2



Catalog Number
Notes
Type

FEATURES & SPECIFICATIONS

INTENDED USE — The Lithonia Lighting JCBL LED Highbay is the affordable LED solution for users who prefer a luminaire with the look and feel of a round form factor. Gymnasiums, warehouses, packaging facilities and other industrial applications all benefit from JCBL's highly efficient design that saves over traditional sources. **Certain airborne contaminants can diminish the integrity of acrylic and/or polycarbonate.** [Click here for Acrylic-Polycarbonate Compatibility table for suitable uses.](#)

Certain airborne contaminants may adversely affect the functioning of LEDs and other electronic components, depending on various factors such as concentrations of the contaminants, ventilation, and temperature at the end-user location. [Click here for a list of substances that may not be suitable for interaction with LEDs and other electronic components.](#)

CONSTRUCTION — JCBL features an aluminum heat sink to maximize heat dissipation and extend the life of the luminaire by maximizing contact with the LEDs. A glass optical enclosure (IP65 rated) protects the LEDs from dust and other air contaminants. Reflector options including aluminum, prismatic acrylic and polycarbonate ship together and easily mount to the heatsink for quick installation.

OPTICS — Reflector and lens options provide maximum versatility and uniformity. Conical, flat or acrylic drop lenses offer enhanced aesthetics, minimize glare at lower mounting heights when paired with acrylic reflectors.

ELECTRICAL — Utilizes 90°C case temperature for maximum life at high temperatures. Less than 20% THD and PF >90. Luminaire Surge Protection Level: Designed to withstand up to 6kV/3kA per ANSI C82.77-5-2015 with MVOLT. Luminaire Surge Protection Level: Designed to withstand up to 10kV/5kA per ANSI C82.77-5-2015 with HVOLT. Input voltages include 120-277, 347/480 without the use of a step down transformer. 0-10V dimming standard for a dimming range of 100% to 10%. Suitable for 50/60Hz.

WIRELESS NETWORKING — Integrated Sensor (nLight Wired Networking): This sensor is nLight-enabled, meaning it has the ability to communicate over an nLight network. When wired, using CAT-5 cabling, with other nLight-enabled sensors, power packs, or WallPods, an nLight control zone is created. Once linked to a Gateway, directly or via a Bridge, the zone becomes capable of remote status monitoring and control via SensorView software.

Integrated Smart Sensor (nLight AIR Wireless Platform): The rSBOR sensor is nLight AIR enabled, meaning it has the ability to communicate over the wireless nLight control platform. It is available with an automatic dimming photocell, and either a digital PIR or dual technology occupancy sensor. It pairs to other luminaires and wall switches through our mobile app, CLAIRITY PRO, which allows for simple sensor adjustment.

INSTALLATION — Mounting options include steel hook & cord or 3/4" NPT threaded hub to accommodate stem or cast hook options.

LISTINGS — UL1598/C SA C22.2 250, Damp location listed. Suitable for use in ambient temperatures from -40°C up to 55°C.

DesignLights Consortium® (DLC) Premium qualified product and DLC qualified product. Not all versions of this product may be DLC Premium qualified or DLC qualified. Please check the DLC Qualified Products List at www.designlights.org/OPL to confirm which versions are qualified.

WARRANTY — 5-year limited warranty. This is the only warranty provided and no other statements in this specification sheet create any warranty of any kind. All other express and implied warranties are disclaimed. Complete warranty terms located at: www.acuitybrands.com/support/warranty/terms-and-conditions

Note: Actual performance may differ as a result of end-user environment and application.

All values are design or typical values, measured under laboratory conditions at 25 °C.

Specifications subject to change without notice.



LED Damp Rated High Bay

JCBL

9000, 12000, 15000, 18000,
24000, 30000 or 36000 lumens



A+ Capable Luminaire

This item is an A+ capable luminaire, which has been designed and tested to provide consistent color appearance and out-of-the-box control compatibility with simple commissioning.

- All configurations of this luminaire meet the Acuity Brands' specification for chromatic consistency
- This luminaire is part of an A+ Certified solution for nLight® control networks marked by a [shaded background](#)*

To learn more about A+, visit www.acuitybrands.com/aplus.

*See ordering tree for details

INDUSTRIAL

LITHONIA-JCBL-JCBL-ROUND BAY-ROUND-LED-
Page 1 of 10



Catalog
Information:

JCBL-24000LM-ACFR-MVOLT-GZ10-35K-80CRI-PM-WG-E10WCP-
DWHXD

Date:01/27/2023
Fixture Type:

B2-EM

Page: 1 of 10

JCBL LED Damp Rated High Bay

DIMENSIONS

All dimensions are in inches (centimeters) unless otherwise indicated.
Dimensions may vary with options or accessories.

Typical weight:

A cartoned luminaire weighs 23 lbs.;
unboxed it weighs 16 lbs.

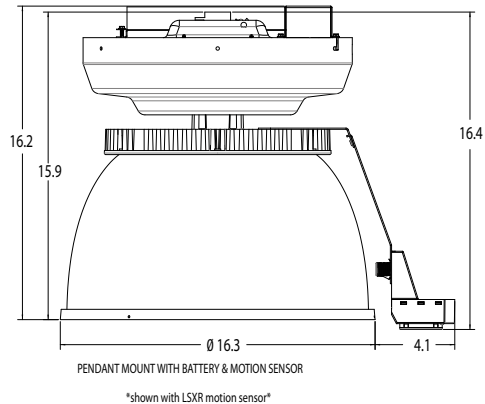
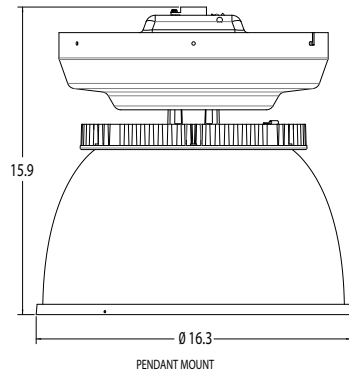

shown with LSXR motion sensor

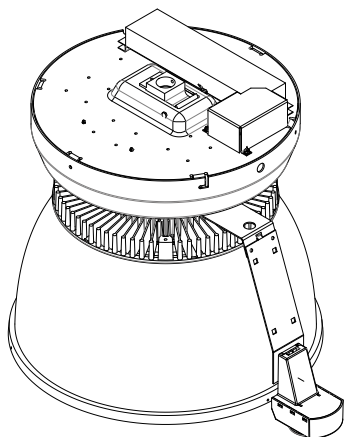

Lithonia-JCBL-JCBL-Round Bay-Round-LED-

INDUSTRIAL: One Lithonia Way, Conyers, GA 30012 Phone: 800-705-SERV (7378) techsupport-industrial@acuitybrands.com www.lithonia.com

© 2016-2022 Acuity Brands Lighting, Inc. All rights reserved. Rev. 05/05/22
Page 2 of 10



Catalog Information: JCBL-24000LM-ACFR-MVOLT-GZ10-35K-80CRI-PM-WG-E10WCP-DWHXD

Date: 01/27/2023
Fixture Type:

B2-EM

JCBL LED Damp Rated High Bay

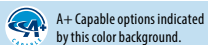

ORDERING INFORMATION Lead times will vary depending on options selected. Consult with your sales representative. **Example:** JCBL 24000LM DALR MVOLT GZ10 40K 80CRI SC6W DWHXD

JCBL Series	Lumens	Reflector	Lens ‡	Voltage	
JCBL	9000LM 9,000 lumens 12000LM 12,000 lumens 15000LM 15,000 lumens 18000LM 18,000 lumens 24000LM 24,000 lumens 30000LM 30,000 lumens 36000LM 36,000 lumens	DALR Diffuse aluminum SALR Specular aluminum ACFR Frosted acrylic ACCR Clear acrylic PLCR Clear polycarbonate	(blank) Open bottom For use with aluminum reflectors ALDRP Drop prismatic ALCON Conical ALFGL Flat prismatic	For use with acrylic and polycarbonate reflectors ACDRP Drop prismatic ACRCON Conical ACRFGF Flat prismatic	MVOLT 120-277V HVOLT 347/480V 120 120V 208 208V 240 240V 277 277V 347 347V 480 480V

GZ10 Driver	Color temperature	Color rendering index	Mounting Configurations
GZ10 0-10V dimming ‡	30K 3000 K 35K 3500 K 40K 4000 K 50K 5000 K	70CRI 70 CRI 80CRI 80 CRI 90CRI 90 CRI	PM Pendant mount SC6W Steel hook & white 6' cord SC6PW Steel hook with white 6' cord and NEMA twist lock plug ‡ SC6PNW Steel hook with white 6' straight blade cordset ‡ SCS6G16WSTOWSD Steel hook with white 6' cord, 16/5, no plug, includes low voltage dimming wires ‡ SC12W Steel hook & 12' white cord SC12PW Steel hook with white 12' cord and NEMA twist lock plug ‡ SC12PNW Steel hook with white 12' straight blade cordset ‡ SCS12G16WSTOWSD Steel hook with white 12' cord, 16/5, no plug, includes low voltage dimming wires ‡

Options	Super Durable Finishes
HOCS Hook, 6' RELOC® OCS ‡ OCS 6' RELOC® OCS ‡ E10WCP EM Self-diagnostics battery pack, 10W, constant power, certified in CA title 20 MAEDBS ‡ BGTD Generator transfer device (120 or 277 only) ‡ WG Wire guard for open bottom reflectors (ships separately) ‡ FWG Full wire guard (ships separately) SCF120 Safety Cable 120" SCF240 Safety cable 240" Cordsets: C6W White 6' cord ‡ C12W White 12' cord ‡ C6PNW White 6' cord with straight blade plug ‡ CS6G16WSTOWSD White 6' cord, 16/5, no plug, includes low voltage dimming wires ‡ HK45S Safety hook, male, cast aluminum, factory installed ‡ HC6W White 6' cord with male cast hook, no plug ‡ HC6PW White 6' cord with male cast hook and NEMA twist lock plug ‡ HC6PNW White 6' cord with male cast hook and straight blade cord ‡ HC6P20W White 6' cord with male cast hook and 20-amp plug ‡ HCS6G16WSTOWSD White 6' cord with male cast hook, 16/5, no plug, includes low voltage dimming wires ‡ Controls: AO Adjustable output ‡ LCOZU Aisle motion sensor, pre-wired LCHOSZU Aisle motion sensor, pre-wired; programmable dimming LCPZU Aisle motion sensor with photocell; pre-wired LAOZU 360° motion sensor, pre-wired LAHOSZU 360° motion sensor, pre-wired; programmable dimming LAPZU 360° motion sensor with photocell, pre-wired	DWXXD White DNAXD Natural aluminum DWHGXD Textured white DNATXD Textured natural aluminum DBLXD Black
Controls: Individual Controls with Bluetooth Programming: LSXBTP 360° High Mount Occ Sensor, pre-wired; Bluetooth® ‡ LSXBTPHL 360° High Mount Occ Sensor w/HL Default, pre-wired; Bluetooth® ‡ LSXBTPADC 360° High Mount Occ Sensor w/ADC Default, pre-wired; Bluetooth® ‡ LSXBTPANL 360° High Mount Occ Sensor w/ANL Default, pre-wired; Bluetooth® ‡ nLight AIR Wireless Controls: ‡ NLTAIR2 RKOA nLight AIR Generation 2 enabled 360° high mount motion sensor NLTAIR2 RKOB nLight AIR Generation 2 enabled 360° low mount motion sensor NLTAIR2 rPP20D nLight AIR Generation 2 dimming and switching module ‡ NLTAIR2 rPP20DER nLight AIR Generation 2 dimming and switching module with emergency relay ‡ nLight Wired Network Controls: NPP16D nLight® switching/dimming module ‡ NPP16DER nLight® switching/dimming module with emergency relay ‡	

NOTE: ‡ indicates option chosen has ordering restrictions. Please reference ordering restrictions chart, page 4. Options are sorted alphanumerically.

Accessories and Notes next page.



Lithonia-JCBL-JCBL-Round Bay-Round-LED-

INDUSTRIAL: One Lithonia Way, Conyers, GA 30012 Phone: 800-705-SERV (7378) techsupport-industrial@acuitybrands.com www.lithonia.com © 2016-2022 Acuity Brands Lighting, Inc. All rights reserved. Rev. 05/05/22 Page 3 of 10



Catalog Information: JCBL-24000LM-ACFR-MVOLT-GZ10-35K-80CRI-PM-WG-E10WCP-DWXXD

Date: 01/27/2023
Fixture Type:

B2-EM

JCBL LED Damp Rated High Bay

Accessories: Order as separate catalog number.	
HK455	Safety hook, male, cast aluminum
JCBLHKF	Hook, female
JCBLSTEM12 XXX	Swivel stem kit, must specify finish.
JCBLSTEM24 XXX	Swivel stem kit, 24", must specify finish.
JCBLSTEM36 XXX	Swivel stem kit, 36", must specify finish.
WGJCBL	Wire guard for use with open bottom reflectors
FWGJCBL	Full wire guard

‡ Option Value Ordering Restrictions	
Option value	Restriction
ACRCON	Lensed fixtures are suitable for use in ambient temperatures up to 40°C.
Lens	Lensed fixtures are suitable for use in ambient temperatures up to 40°C.
AO	Not available with other controls.
BGTD	Only available with 120V or 277V. Not available with MVOLT or HVOLT. Not available with battery packs, plugs, XAD, XAD924, or NLTAIR2 RPP20DER.
C12W	PM option required.
C6W	PM option required.
C6PNW	PM option required. Not available with E10WCP, BGTD, NPP16DER or NLTAIR2 rPP20DER. Must specify voltage. Not available with MVOLT, HVOLT, 347V or 480V. Not available with battery packs.
CS6G16WSTOW5D	PM option required. Not available with E10WCP, BGTD, NPP16DER or NLTAIR2 rPP20DER.
E10WCP	Not available with 347V, 480V or HVOLT. Four conductor cordset ships standard when product is ordered with cord. Utilizes PS1055CP .
GZ10	If ordering a cord and dimming is required for your application, choose CS6G16WSTOW5D, SC12G16WSTOW5D, or HCS6G16WSTOW5D as your cord option.
HC6W	PM option required. Ships standard with HK455 option.
HC6PW	PM option required. Not available with E10WCP, BGTD, NPP16DER or NLTAIR2 rPP20DER. Must specify voltage. 120-277V utilizes a 15-amp plug, 347-480 utilizes a 20-amp plug (standard). Not available with battery packs. Ships standard with HK455 option.
HC6P20W	PM option required. Not available with E10WCP, BGTD, NPP16DER or NLTAIR2 rPP20DER. Must specify voltage. Not available with 347, 480, MVOLT or HVOLT. Not available with battery packs. Ships standard with HK455 option.
HC6PNW	PM option required. Not available with E10WCP, BGTD, NPP16DER or NLTAIR2 rPP20DER. Must specify voltage. Not available with MVOLT or HVOLT. 120-277V utilizes a 15-amp plug, 347-480 utilizes a 20-amp plug (standard). Not available with battery packs. Ships standard with HK455 option.
HCS6G16WSTOW5D	PM option required. Not available with E10WCP, BGTD, NPP16DER or NLTAIR2 rPP20DER. Ships standard with HK455 option.
HK455	PM option required.
HOCS	PM option required. Must specify voltage. Not available with MVOLT or HVOLT. Not available with cordsets. When reloc is selected fixture bears a dry location label. Fixture ships with OCS4C when ordered with battery pack. 120-277V utilizes a 15-amp plug, 347-480 utilizes a 20-amp plug (standard). Ships standard with HK455 option.
LSXBTP	Not able to order 9,000LM or 12,000LM with 347V, 480V, or HVOLT. 9,000LM and 12,000LM will not dim to off if ordered with LSXBTP, LSXBTPHL, LSXBTPADC or LSXBTPANL controls.
LSXBTPHL	Not able to order 9,000LM or 12,000LM with 347V, 480V, or HVOLT. 9,000LM and 12,000LM will not dim to off if ordered with LSXBTP, LSXBTPHL, LSXBTPADC or LSXBTPANL controls.
LSXBTPADC	Not able to order 9,000LM or 12,000LM with 347V, 480V, or HVOLT. 9,000LM and 12,000LM will not dim to off if ordered with LSXBTP, LSXBTPHL, LSXBTPADC or LSXBTPANL controls.
LSXBTPANL	Not able to order 9,000LM or 12,000LM with 347V, 480V, or HVOLT. 9,000LM and 12,000LM will not dim to off if ordered with LSXBTP, LSXBTPHL, LSXBTPADC or LSXBTPANL controls.
nLight AIR Wireless Controls	Normal luminaires (non-emergency) can be used as a normal power sensing device for nearby nLight AIR devices and luminaires with EM emergency options.
NLTAIR2 RPP20D	Not available with HVOLT, 347V, or 480V. Not available with battery or BGTD option.
NLTAIR2 RPP20DER	Not available with HVOLT, 347V, or 480V. Not available with battery or BGTD option.
NPP16D	Must specify voltage. Available with 120V-347V only. Not available with battery or BGTD option.
NPP16DER	Must specify voltage. Available with 120V-347V only. Not available with battery or BGTD option.
OCS	PM option required. Must specify voltage. Not available with MVOLT or HVOLT. Not available with cordsets. When reloc is selected fixture bears a dry location label. Fixture ships with OCS4C when ordered with battery pack. 120-277V utilizes a 15-amp plug, 347-480 utilizes a 20-amp plug (standard). Ships standard with HK455 option.
SC12PW	Not available with E10WCP, BGTD, NPP16DER or NLTAIR2 rPP20DER. Must specify voltage. Not available with MVOLT or HVOLT. 120-277V utilizes a 15-amp plug, 347-480 utilizes a 20-amp plug (standard). Not available with battery packs.
SC12PNW	Not available with E10WCP, BGTD, NPP16DER or NLTAIR2 rPP20DER. Must specify voltage. Not available with MVOLT, HVOLT, 347V or 480V. Not available with battery packs. If black cord is required, remove "W" from nomenclature. Example: SC12P.
SC6PW	Not available with E10WCP, BGTD, NPP16DER or NLTAIR2 rPP20DER. Must specify voltage. Not available with MVOLT or HVOLT. 120-277V utilizes a 15-amp plug, 347-480 utilizes a 20-amp plug (standard). Not available with battery packs.
SC6PNW	Not available with E10WCP, BGTD, NPP16DER or NLTAIR2 rPP20DER. Must specify voltage. Not available with MVOLT, HVOLT, 347V or 480V. If black cord is required, remove "W" from nomenclature. Example: SC6PN.
SCS6G16WSTOW5D	Not available with E10WCP, BGTD, NPP16DER or NLTAIR2 rPP20DER. Not available with battery packs. If black cord is required, remove "W" from nomenclature. Example: SCS6G16STOW5D.
SCS12G16WSTOW5D	Not available with E10WCP, BGTD, NPP16DER or NLTAIR2 rPP20DER. Not available with battery packs. If black cord is required, remove "W" from nomenclature. Example: SCS12G16STOW5D.



Lithonia-JCBL-JCBL-Round Bay-Round-LED-

INDUSTRIAL: One Lithonia Way, Conyers, GA 30012 Phone: 800-705-SERV (7378) techsupport-industrial@acuitybrands.com www.lithonia.com

© 2016-2022 Acuity Brands Lighting, Inc. All rights reserved. Rev. 05/05/22 Page 4 of 10



Catalog Information:

JCBL-24000LM-ACFR-MVOLT-GZ10-35K-80CRI-PM-WG-E10WCP-DWHXD

Date: 01/27/2023
Fixture Type:

B2-EM

Page: 4 of 10

OPERATIONAL DATA

Lumen Package	Input Watts	Ambient Rating	Reflector	Lens	Delivered Lumens											
					3000K CCT, 70CRI	3500K CCT, 70CRI	4000K CCT, 70CRI	5000K CCT, 70CRI	3000K CCT, 80CRI	3500K CCT, 80CRI	4000K CCT, 80CRI	5000K CCT, 80CRI	3000K CCT, 90CRI	3500K CCT, 90CRI	4000K CCT, 90CRI	5000K CCT, 90CRI
9000LM	63	-40°F (-40°C) - 135°F (55°C)	ACCR	-	9628	10046	10186	10256	9418	9418	9558	10046	7814	8023	8163	8581
			ACFR	-	9602	10020	10159	10229	9394	9394	9533	10020	7793	8002	8141	8559
			DALR	-	8045	8395	8511	8569	7870	7870	7987	8395	6529	6704	6821	7170
			PLCR	-	8967	9357	9487	9552	8772	8902	9357	7277	7472	7602	7992	
			SALR	-	8811	9194	9322	9385	8619	8619	8747	9194	7151	7342	7470	7853
			ACCR	ACRCON	9014	9405	9536	9601	8818	8818	8948	9405	7315	7511	7642	8034
			ACFR	ACRCON	9069	9463	9594	9660	8872	8872	9003	9463	7360	7557	7689	8083
			PLCR	ACRCON	8422	8789	8911	8972	8239	8239	8361	8789	6836	7019	7141	7507
			ACCR	ACDRDP	8900	9287	9416	9480	8706	8706	8835	9287	7223	7416	7545	7932
			ACFR	ACDRDP	9082	9477	9608	9674	8884	8884	9016	9477	7371	7568	7700	8095
			PLCR	ACDRDP	8350	8713	8834	8894	8168	8168	8289	8713	6777	6958	7079	7442
			ACCR	ACRFLG	9042	9435	9566	9632	8845	8845	8976	9435	7338	7535	7666	8059
			ACFR	ACRFLG	9102	9498	9630	9696	8904	8904	9036	9498	7387	7585	7717	8113
			PLCR	ACRFLG	8378	8742	8864	8924	8196	8196	8317	8742	6800	6982	7103	7467
			DALR	ALCON	7787	7895	7949	7462	7300	7300	7408	7787	6056	6219	6327	6651
			SALR	ALCON	8529	8648	8707	8174	7996	7996	8115	8529	6634	6812	6930	7286
			DALR	ALDRP	7778	7886	7940	7453	7291	7291	7399	7778	6049	6211	6319	6643
			SALR	ALDRP	8580	8699	8758	8222	8043	8043	8162	8580	6673	6852	6971	7328
			DALR	ALFGL	7613	7719	7772	7296	7138	7138	7243	7613	5922	6080	6186	6503
			SALR	ALFGL	8564	8683	8743	8207	8029	8029	8148	8564	6661	6839	6958	7315
12000LM	84	-40°F (-40°C) - 135°F (55°C)	ACCR	-	12418	12958	13138	13228	12148	12148	12328	12958	10079	10349	10529	11069
			ACFR	-	12386	12924	13104	13193	12116	12116	12296	12924	10052	10321	10501	11039
			DALR	-	10377	10828	10978	11053	10151	10151	10301	10828	8422	8647	8798	9249
			PLCR	-	11566	12069	12236	12320	11314	11314	11482	12069	9387	9638	9806	10309
			SALR	-	11365	11859	12023	12106	11118	11118	11282	11859	9223	9471	9635	10129
			ACCR	ACRCON	11626	12132	12300	12384	11373	11373	11542	12132	9436	9688	9857	10362
			ACFR	ACRCON	11697	12206	12375	12460	11443	11443	11613	12206	9493	9748	9917	10426
			PLCR	ACRCON	10864	11336	11493	11572	10628	10628	10785	11336	8817	9053	9211	9683
			ACCR	ACDRDP	11479	11978	12145	12228	11230	11230	11396	11978	9316	9566	9732	10231
			ACFR	ACDRDP	11714	12223	12393	12478	11459	11459	11629	12223	9507	9762	9932	10441
			PLCR	ACDRDP	10770	11238	11394	11472	10536	10536	10692	11238	8741	8975	9131	9599
			ACCR	ACRFLG	11663	12170	12339	12423	11409	11409	11578	12170	9465	9719	9888	10395
			ACFR	ACRFLG	11740	12251	12421	12506	11485	11485	11655	12251	9528	9784	9954	10464
			PLCR	ACRFLG	10806	11276	11433	11511	10572	10572	10728	11276	8770	9005	9162	9632
			DALR	ALCON	10044	10183	10253	9625	9416	9416	9555	10044	7812	8021	8160	8579
			SALR	ALCON	11002	11155	11231	10543	10314	10314	10467	11002	8557	8786	8939	9397
			DALR	ALDRP	10032	10171	10241	9614	9405	9405	9544	10032	7803	8012	8151	8569
			SALR	ALDRP	11066	11220	11297	10605	10375	10375	10528	11066	8607	8838	8991	9452
			DALR	ALFGL	9820	9956	10025	9411	9206	9206	9343	9820	7638	7842	7979	8388
			SALR	ALFGL	11047	11200	11277	10586	10356	10356	10510	11047	8592	8822	8975	9436



Lithonia-JCBL-JCBL-Round Bay-Round-LED-



Catalog Information: JCBL-24000LM-ACFR-MVOLT-GZ10-35K-80CRI-PM-WG-E10WCP-DWHXD

Date: 01/27/2023
Fixture Type:

B2-EM

JCBL LED Damp Rated High Bay

OPERATIONAL DATA (continued)

Lumen Package	Input Watts	Ambient Rating	Reflector	Lens	Delivered Lumens											
					3000K CCT, 70CRI	3500K CCT, 70CRI	4000K CCT, 70CRI	5000K CCT, 70CRI	3000K CCT, 80CRI	3500K CCT, 80CRI	4000K CCT, 80CRI	5000K CCT, 80CRI	3000K CCT, 90CRI	3500K CCT, 90CRI	4000K CCT, 90CRI	5000K CCT, 90CRI
15000LM	103	-40°F (-40°C) - 135°F (55°C)	ACCR	-	14899	15547	15763	15871	14575	14575	14791	15547	12092	12416	12632	13280
			ACFR	-	14860	15506	15721	15829	14537	14537	14752	15506	12060	12383	12598	13244
			DALR	-	12449	12991	13171	13261	12179	12179	12359	12991	10104	10375	10555	11096
			PLCR	-	13876	14479	14681	14781	13575	13575	13776	14479	11262	11563	11765	12368
			SALR	-	13635	14228	14425	14524	13338	13338	13536	14228	11066	11362	11560	12153
			ACCR	ACRCON	13948	14555	14757	14858	13645	13645	13847	14555	11321	11624	11826	12432
			ACFR	ACRCON	14034	14644	14847	14949	13729	13729	13932	14644	11390	11695	11898	12508
			PLCR	ACRCON	13034	13600	13789	13884	12750	12750	12939	13600	10578	10861	11050	11617
			ACCR	ACDRP	13772	14371	14571	14670	13473	13473	13672	14371	11177	11477	11676	12275
			ACFR	ACDRP	14054	14665	14869	14971	13749	13749	13952	14665	11406	11712	11915	12526
			PLCR	ACDRP	12921	13483	13670	13764	12640	12640	12828	13483	10487	10768	10955	11517
			ACCR	ACRFLG	13992	14601	14804	14905	13688	13688	13891	14601	11356	11660	11863	12471
			ACFR	ACRFLG	14085	14698	14902	15004	13779	13779	13983	14698	11432	11738	11942	12554
			PLCR	ACRFLG	12965	13529	13717	13811	12683	12683	12871	13529	10522	10804	10992	11556
			DALR	ALCON	12050	12217	12301	11548	11297	11297	11464	12050	9372	9623	9791	10293
			SALR	ALCON	13199	13383	13474	12649	12374	12374	12558	13199	10266	10541	10725	11274
			DALR	ALDRP	12036	12203	12286	11534	11283	11283	11451	12036	9361	9612	9779	10281
			SALR	ALDRP	13277	13461	13553	12724	12447	12447	12631	13277	10326	10603	10787	11341
			DALR	ALFGL	11782	11945	12027	11291	11045	11045	11209	11782	9164	9409	9573	10064
			SALR	ALFGL	13253	13437	13529	12701	12425	12425	12609	13253	10308	10584	10768	11320
18000LM	125	-40°F (-40°C) - 135°F (55°C)	ACCR	-	18253	19047	19311	19443	17856	17856	18121	19047	14814	15211	15475	16269
			ACFR	-	18205	18996	19260	19392	17809	17809	18073	18996	14775	15171	15434	16226
			DALR	-	15252	15915	16136	16247	14920	14920	15141	15915	12378	12710	12931	13594
			PLCR	-	17000	17739	17985	18109	16630	16630	16877	17739	13797	14167	14413	15152
			SALR	-	16704	17430	17672	17794	16341	16341	16583	17430	13557	13920	14162	14888
			ACCR	ACRCON	17088	17831	18079	18203	16717	16717	16965	17831	13869	14240	14488	15231
			ACFR	ACRCON	17193	17941	18190	18314	16819	16819	17068	17941	13954	14328	14577	15324
			PLCR	ACRCON	15968	16662	16894	17009	15621	15621	15852	16662	12959	13307	13538	14232
			ACCR	ACDRP	16873	17606	17851	17973	16506	16506	16750	17606	13694	14060	14305	15039
			ACFR	ACDRP	17218	17966	18216	18341	16844	16844	17093	17966	13974	14348	14598	15346
			PLCR	ACDRP	15830	16518	16748	16862	15486	15486	15715	16518	12847	13192	13421	14109
			ACCR	ACRFLG	17142	17888	18136	18260	16770	16770	17018	17888	13913	14285	14534	15279
			ACFR	ACRFLG	17256	18006	18257	18382	16881	16881	17131	18006	14005	14380	14630	15381
			PLCR	ACRFLG	15884	16574	16805	16920	15538	15538	15769	16574	12891	13236	13467	14157
			DALR	ALCON	14762	14967	15070	14147	13840	13840	14045	14762	11482	11789	11995	12610
			SALR	ALCON	16171	16395	16508	15497	15160	15160	15385	16171	12577	12914	13139	13813
			DALR	ALDRP	14745	14950	15052	14131	13824	13824	14028	14745	11468	11776	11980	12595
			SALR	ALDRP	16266	16492	16605	15588	15249	15249	15475	16266	12651	12990	13216	13894
			DALR	ALFGL	14434	14634	14735	13833	13532	13532	13732	14434	11226	11527	11728	12329
			SALR	ALFGL	16237	16462	16575	15560	15222	15222	15447	16237	12628	12967	13192	13869



Lithonia-JCBL-JCBL-Round Bay-Round-LED-

INDUSTRIAL: One Lithonia Way, Conyers, GA 30012 Phone: 800-705-SERV (7378) techsupport-industrial@acuitybrands.com www.lithonia.com

© 2016-2022 Acuity Brands Lighting, Inc. All rights reserved. Rev. 05/05/22

Page 6 of 10



Catalog Information:

JCBL-24000LM-ACFR-MVOLT-GZ10-35K-80CRI-PM-WG-E10WCP-DWHXD

Date: 01/27/2023
Fixture Type:

B2-EM

Page: 6 of 10

JCBL LED Damp Rated High Bay

OPERATIONAL DATA (continued)

Lumen Package	Input Watts	Ambient Rating	Reflector	Lens	Delivered Lumens											
					3000K CCT, 70CRI	3500K CCT, 70CRI	4000K CCT, 70CRI	5000K CCT, 70CRI	3000K CCT, 80CRI	3500K CCT, 80CRI	4000K CCT, 80CRI	5000K CCT, 80CRI	3000K CCT, 90CRI	3500K CCT, 90CRI	4000K CCT, 90CRI	5000K CCT, 90CRI
24000LM	160	-40°F (-40°C) - 135°F (55°C)	ACCR	-	23693	24723	25066	25238	23178	23178	23521	24723	19229	19744	20087	21118
			ACFR	-	23630	24658	25000	25171	23117	23117	23459	24658	19178	19692	20034	21062
			DALR	-	19797	20658	20945	21089	19367	19367	19654	20658	16067	16498	16785	17646
			PLCR	-	22066	23026	23346	23505	21587	21587	21906	23026	17909	18389	18708	19668
			SALR	-	21682	22625	22939	23096	21211	21211	21525	22625	17597	18069	18383	19326
			ACCR	ACRCON	22181	23146	23467	23628	21699	21699	22021	23146	18002	18484	18806	19770
			ACFR	ACRCON	22317	23287	23611	23773	21832	21832	22155	23287	18112	18598	18921	19891
			PLCR	ACRCON	20727	21628	21928	22078	20276	20276	20577	21628	16822	17272	17573	18474
			ACCR	ACDRDP	21901	22853	23171	23329	21425	21425	21742	22853	17775	18251	18568	19520
			ACFR	ACDRDP	22349	23321	23645	23807	21863	21863	22187	23321	18138	18624	18948	19920
			PLCR	ACDRDP	20548	21441	21739	21888	20101	20101	20399	21441	16676	17123	17421	18314
			ACCR	ACRFLG	22251	23219	23541	23702	21767	21767	22090	23219	18059	18543	18865	19833
			ACFR	ACRFLG	22399	23373	23697	23860	21912	21912	22237	23373	18179	18666	18990	19964
			PLCR	ACRFLG	20617	21514	21813	21962	20169	20169	20468	21514	16733	17181	17480	18376
			DALR	ALCON	19162	19428	19561	18364	17964	17964	18231	19162	14904	15303	15569	16368
			SALR	ALCON	20990	21282	21427	20115	19678	19678	19970	20990	16326	16763	17054	17929
			DALR	ALDRP	19140	19405	19538	18342	17943	17943	18209	19140	14886	15285	15551	16348
			SALR	ALDRP	21113	21407	21553	20234	19794	19794	20087	21113	16421	16861	17155	18034
			DALR	ALFGL	18736	18996	19126	17955	17565	17565	17825	18736	14572	14962	15223	16003
			SALR	ALFGL	21076	21368	21515	20197	19758	19758	20051	21076	16392	16831	17124	18002
30000LM	204	-40°F (-40°C) - 135°F (55°C)	ACCR	-	29714	31006	31437	31652	29068	29068	29499	31006	24116	24762	25193	26484
			ACFR	-	29636	30924	31354	31569	28992	28992	29421	30924	24052	24696	25126	26414
			DALR	-	24829	25908	26268	26448	24289	24289	24649	25908	20151	20691	21051	22130
			PLCR	-	27674	28878	29279	29479	27073	27073	27474	28878	22460	23062	23463	24666
			SALR	-	27193	28375	28769	28966	26602	26602	26996	28375	22070	22661	23055	24237
			ACCR	ACRCON	27819	29028	29431	29633	27214	27214	27617	29028	22577	23182	23585	24795
			ACFR	ACRCON	27989	29206	29611	29814	27380	27380	27786	29206	22716	23324	23730	24947
			PLCR	ACRCON	25994	27124	27501	27690	25429	25429	25806	27124	21097	21662	22039	23169
			ACCR	ACDRDP	27467	28661	29059	29258	26870	26870	27268	28661	22292	22889	23287	24482
			ACFR	ACDRDP	28029	29248	29654	29857	27420	27420	27826	29248	22748	23358	23764	24982
			PLCR	ACDRDP	25770	26890	27264	27450	25209	25209	25583	26890	20915	21475	21848	22969
			ACCR	ACRFLG	27906	29119	29524	29726	27299	27299	27704	29119	22648	23255	23660	24873
			ACFR	ACRFLG	28092	29313	29720	29924	27481	27481	27888	29313	22799	23410	23817	25038
			PLCR	ACRFLG	25857	26982	27356	27544	25295	25295	25670	26982	20986	21548	21922	23047
			DALR	ALCON	24032	24366	24533	23031	22530	22530	22864	24032	18692	19192	19526	20527
			SALR	ALCON	26325	26690	26873	25228	24679	24679	25045	26325	20475	21023	21389	22486
			DALR	ALDRP	24004	24337	24504	23004	22504	22504	22837	24004	18670	19170	19503	20503
			SALR	ALDRP	26479	26847	27031	25376	24824	24824	25192	26479	20595	21147	21514	22618
			DALR	ALFGL	23497	23823	23987	22518	22029	22029	22355	23497	18276	18765	19091	20070
			SALR	ALFGL	26432	26799	26982	25330	24780	24780	25147	26432	20558	21109	21476	22577



Lithonia-JCBL-JCBL-Round Bay-Round-LED-



Catalog Information:

JCBL-24000LM-ACFR-MVOLT-GZ10-35K-80CRI-PM-WG-E10WCP-DWHXD

Date: 01/27/2023
Fixture Type:

B2-EM

JCBL LED Damp Rated High Bay

OPERATIONAL DATA (continued)

Lumen Package	Input Watts	Ambient Rating	Reflector	Lens	Delivered Lumens											
					3000K CCT, 70CRI	3500K CCT, 70CRI	4000K CCT, 70CRI	5000K CCT, 70CRI	3000K CCT, 80CRI	3500K CCT, 80CRI	4000K CCT, 80CRI	5000K CCT, 80CRI	3000K CCT, 90CRI	3500K CCT, 90CRI	4000K CCT, 90CRI	5000K CCT, 90CRI
36000LM	249	-40°F (-40°C) - 135°F (45°C)	ACCR	-	34589	36093	36594	36845	33837	33837	34338	36093	28072	28824	29325	30829
			ACFR	-	34497	35997	36497	36747	33747	33747	34247	35997	27998	28748	29248	30748
			DALR	-	28902	30158	30577	30787	28274	28274	28692	30158	23457	24085	24504	25760
			PLCR	-	32214	33615	34082	34315	31514	31514	31981	33615	26145	26845	27312	28713
			SALR	-	31654	33030	33489	33718	30966	30966	31424	33030	25690	26378	26837	28213
			ACCR	ACRCON	32382	33790	34259	34494	31678	31678	32147	33790	26281	26985	27454	28862
			ACFR	ACRCON	32580	33997	34469	34705	31872	31872	32344	33997	26442	27150	27622	29039
			PLCR	ACRCON	30259	31574	32013	32232	29601	29601	30039	31574	24558	25215	25654	26970
			ACCR	ACDRP	31973	33363	33826	34058	31278	31278	31741	33363	25949	26644	27107	28498
			ACFR	ACDRP	32627	34046	34519	34755	31918	31918	32391	34046	26480	27189	27662	29081
			PLCR	ACDRP	29997	31301	31736	31953	29345	29345	29780	31301	24345	24998	25432	26737
			ACCR	ACRFL	32484	33896	34367	34602	31778	31778	32249	33896	26364	27070	27541	28953
			ACFR	ACRFL	32700	34122	34595	34832	31989	31989	32463	34122	26539	27250	27724	29145
			PLCR	ACRFL	30099	31408	31844	32062	29445	29445	29881	31408	24428	25083	25519	26827
			DALR	ALCON	27974	28363	28557	26809	26226	26226	26614	27974	21758	22341	22729	23895
			SALR	ALCON	30643	31069	31281	29366	28728	28728	29153	30643	23833	24472	24897	26174
			DALR	ALDRP	27941	28329	28524	26777	26195	26195	26583	27941	21732	22314	22702	23867
			SALR	ALDRP	30823	31251	31465	29539	28896	28896	29325	30823	23973	24615	25044	26328
			DALR	ALFGL	27352	27732	27922	26212	25642	25642	26022	27352	21274	21843	22223	23363
			SALR	ALFGL	30768	31195	31409	29486	28845	28845	29272	30768	23930	24571	24999	26281

UPLIGHT PERCENTAGES (*Based on 24,000LM 40K 80CRI)

Reflector Option	Flat Lens	Conical Lens	Drop Lens	L/Lens
ACFR	18.0%	17.0%	17.4%	13.1%
ACCR	7.2%	5.8%	7.4%	2.7%
PLCR	6.6%	5.0%	6.8%	2.2%
SALR	0.1%	0.1%	1.7%	0.0%
DALR	0.1%	0.1%	1.8%	0.1%

AO CHART

Lumen Package	AO Position	% Lumen Output		% Wattage		
		AO Position	% Lumen Output	% Wattage	% Wattage	
9000LM	1	37%	38%			
	2	50%	49%			
	3	63%	62%			
	4	76%	74%			
	5	89%	87%			
	6	100%	100%			
	7	100%	100%			
	8	100%	100%			
12000LM	1	38%	36%			
	2	51%	48%			
	3	64%	60%			
	4	76%	74%			
	5	89%	87%			
	6	100%	100%			
	7	100%	100%			
	8	100%	100%			
18000LM	1	38%	36%			
	2	51%	48%			
	3	64%	61%			
	4	77%	74%			
18000LM	5	89%	87%			
	6	100%	100%			
	7	100%	100%			
	8	100%	100%			
	24000LM	1	38%	36%		
		2	51%	48%		
		3	64%	61%		
		4	77%	74%		
5		89%	87%			
6		100%	100%			
7		100%	100%			
8		100%	100%			
30000LM	1	38%	35%			
	2	51%	48%			
	3	64%	61%			
	4	77%	74%			
	5	89%	87%			
	6	100%	100%			
	7	100%	100%			
	8	100%	100%			
30000LM	1	39%	37%			
	2	52%	49%			
	3	65%	62%			
	4	77%	75%			
	5	89%	88%			
	6	100%	100%			
	7	100%	100%			
	8	100%	100%			
36000LM	1	39%	36%			
	2	53%	49%			
	3	66%	61%			
	4	78%	74%			
	5	90%	87%			
	6	100%	100%			
	7	100%	100%			
	8	100%	100%			



Lithonia-JCBL-JCBL-Round Bay-Round-LED-

INDUSTRIAL: One Lithonia Way, Conyers, GA 30012 Phone: 800-705-SERV (7378) techsupport-industrial@acuitybrands.com www.lithonia.com

© 2016-2022 Acuity Brands Lighting, Inc. All rights reserved. Rev. 05/05/22

Page 8 of 10



Catalog Information:

JCBL-24000LM-ACFR-MVOLT-GZ10-35K-80CRI-PM-WG-E10WCP-DWHXD

Date: 01/27/2023
Fixture Type:

B2-EM

JCBL LED Damp Rated High Bay

OPERATIONAL DATA (continued)

LUMEN MAINTENANCE TABLE

Lumen Package	25,000	35,000	50,000	60,000
9000LM	0.97	0.96	0.95	0.94
12000LM	0.97	0.96	0.95	0.94
15000LM	0.96	0.95	0.94	0.93
18000LM	0.96	0.95	0.94	0.93
24000LM	0.96	0.95	0.93	0.93
30000LM	0.95	0.94	0.93	0.92
36000LM	0.95	0.93	0.91	0.90

LAT TABLE VS. AMBIENT TEMPERATURE (C)

Lumen Package	25	30	35	40	45	50	55
9000LM	1.00	1.00	0.99	0.99	0.98	0.98	0.97
12000LM	1.00	1.00	0.99	0.98	0.98	0.97	0.97
15000LM	1.00	0.99	0.99	0.98	0.98	0.97	0.96
18000LM	1.00	0.98	0.98	0.97	0.96	0.96	0.95
24000LM	1.00	0.99	0.99	0.98	0.97	0.97	0.96
30000LM	1.00	0.99	0.99	0.98	0.97	0.97	
36000LM	1.00	0.99	0.99	0.98			

REFLECTORS AND LENSES



Aluminum reflector
Available specular (SALR) or diffuse (DALR)



Acrylic frosted reflector (ACFR)



Clear acrylic (ACCR) or polycarbonate reflector (PLCR)



Acrylic drop lens (ACDRP)



Flat prismatic lens (ALFGL)



Conical lens (ALCON)

OPTIONS AND ACCESSORIES



Full Wire Guard (FWG)
All dimensions are in inches.

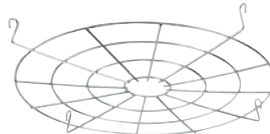
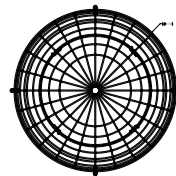

Wire Guard (WG)



Safety Cable (JCBLSC120 or JCBLSC240)



Cast Hook Female (JCBLHKF)



Lithonia-JCBL-JCBL-Round Bay-Round-LED-

INDUSTRIAL: One Lithonia Way, Conyers, GA 30012 Phone: 800-705-SERV (7378) techsupport-industrial@acuitybrands.com www.lithonia.com

© 2016-2022 Acuity Brands Lighting, Inc. All rights reserved. Rev. 05/05/22
Page 9 of 10



Catalog
Information:

JCBL-24000LM-ACFR-MVOLT-GZ10-35K-80CRI-PM-WG-E10WCP-DWHXD

Date: 01/27/2023
Fixture Type:

B2-EM

Page: 9 of 10

SELECTIONS BELOW WILL EXTEND ORDER LEAD TIME. CONSULT YOUR SALES REPRESENTATIVE FOR DETAILS.

SINGLE RELAY

ORDERING INFORMATION

Example: LAHOSZU

Series	Lens option	Dimming/Photocell	Max. dim level	Min. dim level	Temp/Humidity	Default occupancy time delay
L LSXR passive infrared indoor occupancy sensor	A High mount, 360°	O None ¹	0 10 VDC	5 Minimum dim level of ballast	Z None	I 30 sec
	B Low mount, 360°	H High/low occupancy operation	9 9 VDC	1 1 VDC	T Low temperature ²	D 2.5 min
	C High mount aisleway	P Switching photocell (on/off) ¹	8 8 VDC	2 2 VDC	3 3 VDC	X 5.0 min
		M Dimming and switching photocell	7 7 VDC	4 4 VDC	5 5 VDC	R 7.5 min
		G Dimming and switching photocell with high/low occupancy operation		6 6 VDC		U 10.0 min (with minimum 15 minute on time)
						V 15.0 min
						W 20.0 min
				Y 30.0 min		

Notes

- 1 Max and min dim levels not applicable with this option.
- 2 Ambient temperature rating of -4°F (-20°C) to 131°F (55°C).

Example: LENS 50 J100

Replacement lenses: Order as separate catalog number.		
Series	Lens type	Package quantity
LENS	6 High mount 360°	[blank] Single Lens
	10 Low mount 360°	J10 10-pack
	50 High mount aisleway	J100 100-pack

Bluetooth Sensor

Model	Default Operation	LSXR Equivalent	Occupancy Time Delay	Photocell Mode	Photocell Set-point	Low Trim	High Trim	Dim to Off Time Delay
LSXBTP	On/Off Occupancy Only Disabled	LSXR 10 LT or LBO0STU	10 minutes	Disabled	n/a	n/a	100%	Disabled
LSXBPHL	Occupancy w/ 0-10V Dimming (High/Low/Off)	LSXR 10 HL LT or LBHOSTU	10 minutes	Disabled	n/a	10%	100%	2.5 minutes
LSXBTPADC	Occupancy w/ Dim & Switch Photocell	LSXR 10 ADC LT or LBMOSTU	10 minutes	On/Off & Auto Dim	50 fc	10%	100%	0 seconds
LSXBTPANL	Dim & Switch Photocell with High/Low Occupancy Operation	LSXR 10 ANL LT or LBGOSTU	10 minutes	On/Off & Auto Dim	50 fc	10%	100%	Stay Dim/Never Off

SBG BTP Wireless Sensor: [Web Page](#) | [Presentation](#)

VLP Mobile App: [Web Page](#) | [Sell Sheet](#) | [FAQ](#) | [User Guide](#) | [Configuration Video](#)

PHOTOMETRICS

See www.lithonia.com.



Lithonia-JCBL-JCBL-Round Bay-Round-LED-

INDUSTRIAL: One Lithonia Way, Conyers, GA 30012 Phone: 800-705-SERV (7378) techsupport-industrial@acuitybrands.com www.lithonia.com

© 2016-2022 Acuity Brands Lighting, Inc. All rights reserved. Rev. 05/05/22 Page 10 of 10



Catalog Information:

JCBL-24000LM-ACFR-MVOLT-GZ10-35K-80CRI-PM-WG-E10WCP-DWHXD

Date:01/27/2023
Fixture Type:

B2-EM

Project		Catalog #		Type	
Prepared by		Notes		Date	

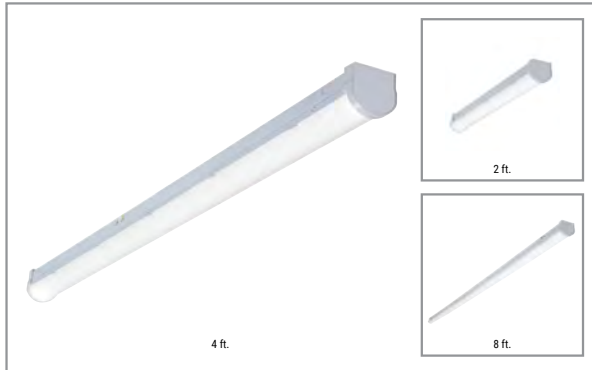

Metalux

SLSTP Lensed LED

Selectable CCT and Lumen LED Striplight

Typical Applications
Commercial • Industrial • Retail • Residential

Interactive Menu

- Order Information [page 2](#)
- Photometric Data [page 4](#)
- Sensor Coverage [page 5](#)
- Product Warranty

Product Certification



Product Features



Top Product Features

- External selectable switches provide easy, in field customization
- (3) color temperature and lumen select option provide application versatility
- Single frost lens (no breaks) provides clean, continuous lighting layout
- Up to 143 LPW and DLC compliant to enable rebates and energy savings
- Available in 8ft, 4ft and 2ft lengths, single and continuous mount capable
- UNV and 347V driver with 0-10V dimming, 10% standard
- Jbox cover, decorative endcap included to complete install.

Dimensional and Mounting Details

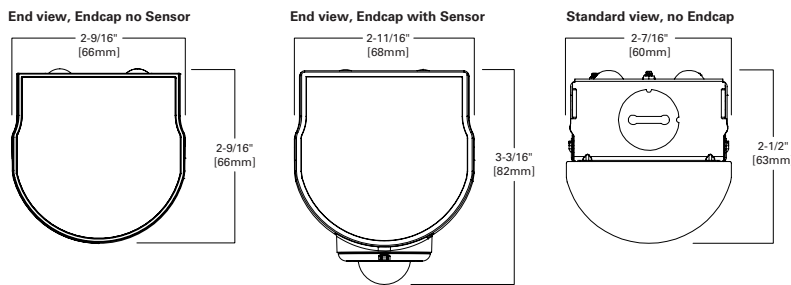

[additional product diagrams](#)



PS51969122 page 1
September 20, 2022 7:56 AM



Catalog Information: 4SLSTPSLC-UNV

Date:01/27/2023
Fixture Type:

B3

Order Information and Performance Data

Catalog #	UPC	Length	CCT (K)	Delivered Lumens	Watts	Efficacy (lm/W)	Dimming (Triac or 0-10V)	Input Current (A)		
								120V	277V	347V
2SLSTPSC-UNV	080083174409	2	3500	2445	22	113	0-10V Dim to 10%	0.18	0.08	-
			4000	2585	21	123		0.17	0.08	
			5000	2470	21	115		0.18	0.08	
			3500	2416	18	133		0.15	0.07	-
			4000	2418	18	137		0.15	0.06	
			5000	2383	18	134		0.15	0.06	
4SLSTPSC-UNV	080083174416	4	3500	3534	31	115	0-10V Dim to 10%	0.26	0.11	-
			4000	3627	30	122		0.25	0.11	
			5000	3523	30	116		0.25	0.11	
			3500	5802	48	121		0.40	0.17	-
			4000	6045	46	130		0.39	0.17	
			5000	5784	48	121		0.40	0.17	
			3500	4215	34	125		0.28	0.12	
			4000	4321	33	130		0.28	0.12	
8SLSTPSC-UNV	080083174423	8	5000	4288	34	127	0-10V Dim to 10%	0.28	0.12	-
			3500	7782	64	121		0.54	0.23	
			4000	8141	63	130		0.52	0.23	
			5000	7901	64	123		0.54	0.23	
			3500	10456	88	118		0.74	0.32	
			4000	11119	85	130		0.71	0.31	
			5000	10456	89	118		0.74	0.32	
			3500	2489	22	114		-	-	
2SLSTPSC-347	080083249442	2	4000	2631	21	125	0-10V Dim to 10%	-	-	0.06
			5000	2538	22	117		-	-	0.06
			3500	2339	18	127		-	-	0.05
4SLSTPSC-347	080083249466	4	4000	2446	18	134	0-10V Dim to 10%	-	-	0.05
			5000	2386	18	130		-	-	0.05
			3500	3479	31	113		-	-	0.09
			4000	3669	30	121		-	-	0.09
			5000	3550	31	115		-	-	0.09
			3500	5736	47	122		-	-	0.14
			4000	6115	46	133		-	-	0.13
			5000	5852	47	124		-	-	0.14
			8SLSTPSC-347	080083249480	8	3500		4419	33	136
4000	4556	32				143	-	-	0.09	
5000	4521	32				140	-	-	0.09	
3500	7937	64				124	-	-	0.18	
4000	8325	62				134	-	-	0.18	
5000	8254	65				127	-	-	0.19	
3500	10622	87				123	-	-	0.25	
4000	11202	84				134	-	-	0.24	
5000	10692	86	124	-	-	0.25				

Energy Data - 120V

	2'	4'	8'
PF	0.99	0.99	0.99
THD%	< 8.5	< 9.9	< 8.1
Low Temp Start	-20°C	-20°C	-20°C

Shipping Data

Catalog Base	Wt. (lbs)	Unit per Pallet	Case Pack Qty.
2SLSTP	2.5	180	6
4SLSTP	4.5	120	4
8SLSTP	8	100	2



Factory Installed Mod Shop Option

Catalog	Emergency Battery Installed ^{(2), (4)}
2SLSTP* - ___	BSL6 = Bodine 6W Emergency BSL10 = Bodine 10W Emergency
4SLSTP* - ___	
8SLSTP* - ___	

Example: 4SLSTPSLC-UNV-BSL10

ROW ALIGNER 8' - 8' ROW ALIGNER 8' - 4'

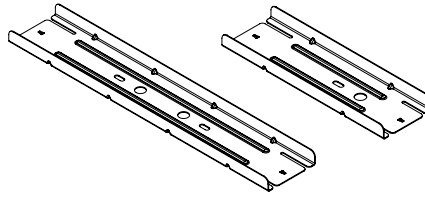

Accessories

AVC-Chain/Set=36" Hanging Chain Set w/V Hooks
Y-Toggle-10-2PK=(2) Y-Toggle Cable Kits at 10FT long ⁽¹⁾
SCF-12-8-12" Fixed Stem Set (specify if another length is needed) ⁽¹⁾
2SLSTPLNS=2 ft. Replacement Lens
4SLSTPLNS=4 ft. Replacement Lens
8SLSTPLNS=8 ft. Replacement Lens
EBPLED7W=User Installed, Remote Mount, 7 Watt LED Emergency Battery Pack
EBPLED14W=User Installed, Remote Mount, 14 Watt LED Emergency Battery Pack
SLSTPMS00 KIT=Field installable sensor kit, PIR Sensor 100% 50% OFF
SLSTPMS25 KIT=Field installable sensor kit, PIR Sensor 100% 50% Low (~30%)
SLSTPROW88=8ft to 8ft continuous row bracket
SLSTPROW842=8ft to 4ft or 2ft continuous row bracket

Notes: (1) For stem, order two per fixture.
 (2) For approximate delivered lumens multiply the lumens per watt of the desired fixture by the wattage of the emergency battery pack (100 lm/W x 7-700 lumens).
 (3) Continuous row mount only between fixtures.
 (4) EBP not available at 347V

Catalog	Unit UPC	Unit Carton Qty	Case Qty
SLSTPROW88	080083815654	1	50
SLSTPROW842	080083815661	1	50

SLSTP MOTION SENSOR KIT (COMING SOON)

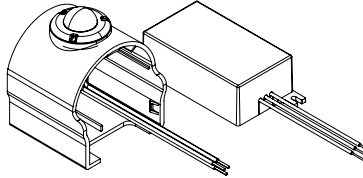

Catalog	Unit UPC	Unit Carton Qty	Case Qty
SLSTP MS00 Kit	080083254200	1	50
SLSTP MS25 Kit	080083254224	1	50

Product Specifications

Construction

- Fixture channel, cover and end plates are formed from cold rolled steel
- Decorative end caps snap-on for an improved aesthetic finish
- Suitable for either single or continuous row applications

Electrical

- Long-Life LED system with an energy-efficient electronic driver comes in UNV (120-277V) or 120/347V versions
- Available with 0-10V dimming
- CCT Selectable option for maximum color flexibility: choose from 3500K, 4000K or 5000K
- LED and Light Engine
 - Lumen select switch provides three lumen package choices (Low, Medium and High)
 - L70 at >50,000 hours (TM-21), over 23 years at 6 hrs/day
 - CRI 83 or better

Controls

- Maximize energy savings - combine with products like occupancy sensors, daylighting controls, and lighting relay panels
- Standard 0-10V continuous dimming driver works with any standard 0-10V control/dimmer
- Dimming range is 10% to 100% and varies by control device
- Purple and grey (pink) low voltage dimming leads required from 0-10V dimmer switch to fixture
- PIR occupancy sensors enables code compliance. Refer to accessory kit for setting levels.
- Sensor kit can be field installed. Add up to (20) 4ft or (10) 8ft fixtures per single sensor kit. Kit is end mount only.

Finish

- Post painted with high reflective paint – standard, for ease of handling

Shielding

- Frost, polycarbonate lens with linear prisms for uniform light distribution

Emergency Battery Pack Option

- Factory installed 120V-277V integral emergency battery pack available via mod-shop.
- 90-minute backup period for code compliance
- Factory installed integral test switch visible from row side

Installation

- May be surface, suspended, or wall mounted
- Multiple 7/8" K.O. on back and one on each end
- Jbox cover, wire nuts and decorative end caps included

Compliance

- cULus listed for damp location rated
- LED's comply with IESNA LM-79 and LM-80 standards
- DesignLights Consortium® Qualified and classified for DLC Standard, refer to www.designlights.org for details
- RoHS compliant
- Suitable for use in closet storage spaces when installed in accordance with NFPA-70 and NEC 410.16 spacing requirements

Warranty

- Five year limited warranty

Photometric Data

[View IES files](#)

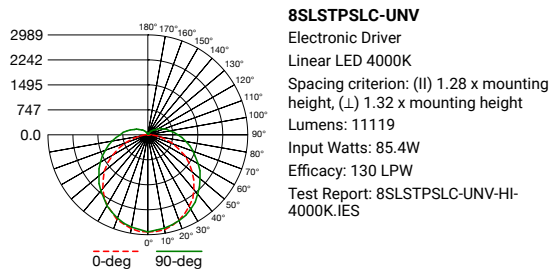
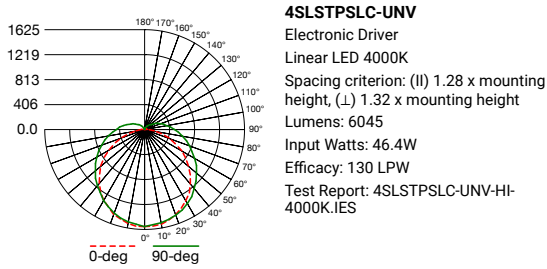
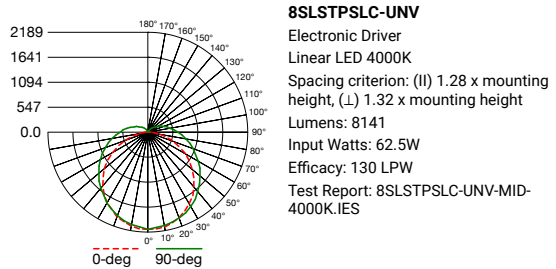
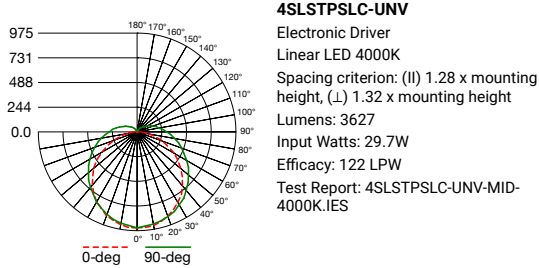
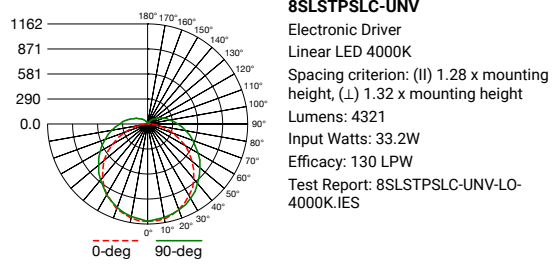
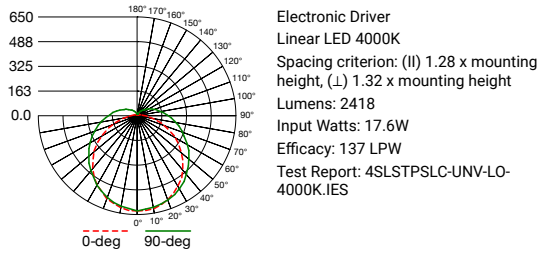

PS51969122 page 4
 September 20, 2022 7:56 AM



Catalog Information: 4SLSTPSLC-UNV

Date:01/27/2023
 Fixture Type:

B3

Mounting Dimensions

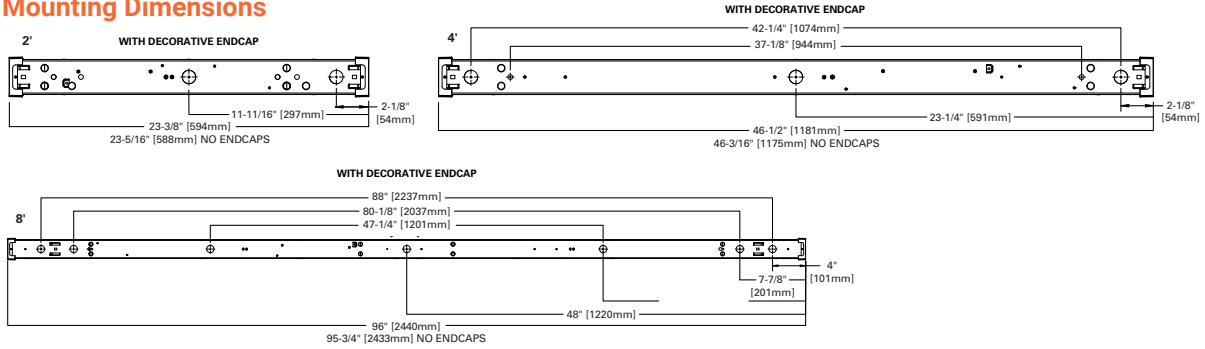

Overall Dimensions

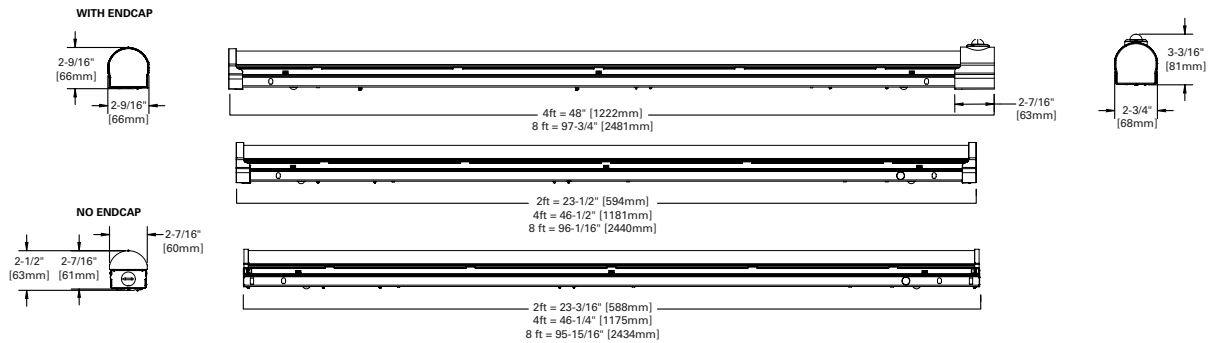

Sensor Coverage (MS Sensor Kit)

SENSOR COVERAGE PATTERN - TOP VIEW

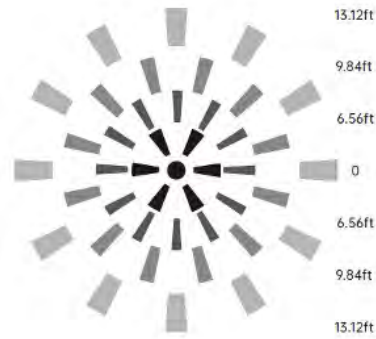

SIDE VIEW

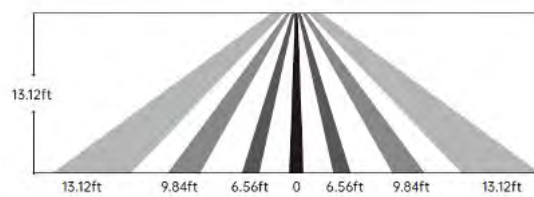

LIGHT OUTPUT OVER TIME

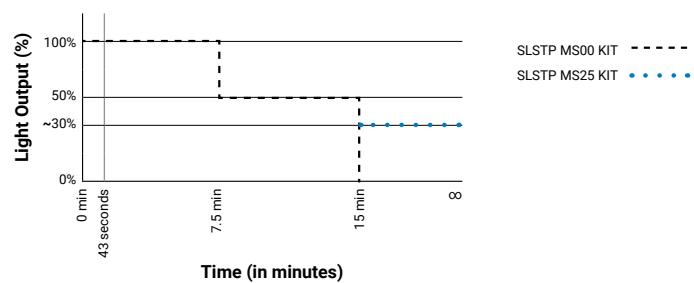

Project		Catalog #		Type	
Prepared by		Notes		Date	

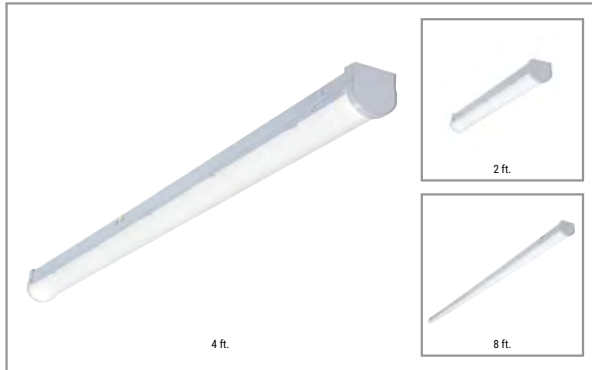

Metalux

SLSTP Lensed LED

Selectable CCT and Lumen LED Striplight

Typical Applications

Commercial • Industrial • Retail • Residential

Interactive Menu

- Order Information [page 2](#)
- Photometric Data [page 4](#)
- Sensor Coverage [page 5](#)
- Product Warranty

Product Certification



Product Features



Top Product Features

- External selectable switches provide easy, in field customization
- (3) color temperature and lumen select option provide application versatility
- Single frost lens (no breaks) provides clean, continuous lighting layout
- Up to 143 LPW and DLC compliant to enable rebates and energy savings
- Available in 8ft, 4ft and 2ft lengths, single and continuous mount capable
- UNV and 347V driver with 0-10V dimming, 10% standard
- Jbox cover, decorative endcap included to complete install.

Dimensional and Mounting Details

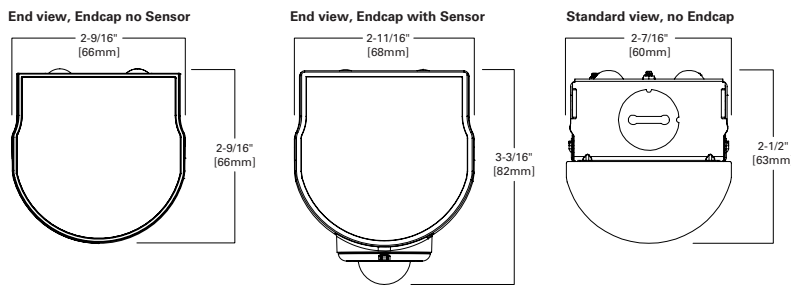

[additional product diagrams](#)



PS51969122 page 1
September 20, 2022 7:56 AM



Catalog Information: 4SLSTPSLC-UNV-BSL10

Date:01/27/2023
Fixture Type:

B3-EM

Order Information and Performance Data

Catalog #	UPC	Length	CCT (K)	Delivered Lumens	Watts	Efficacy (lm/W)	Dimming (Triac or 0-10V)	Input Current (A)			
								120V	277V	347V	
2SLSTPSC-UNV	080083174409	2	3500	2445	22	113	0-10V Dim to 10%	0.18	0.08	-	
			4000	2585	21	123		0.17	0.08		
			5000	2470	21	115		0.18	0.08		
			3500	2416	18	133		0.15	0.07	-	
			4000	2418	18	137		0.15	0.06		
			5000	2383	18	134		0.15	0.06		
4SLSTPSC-UNV	080083174416	4	3500	3534	31	115	0-10V Dim to 10%	0.26	0.11	-	
			4000	3627	30	122		0.25	0.11		
			5000	3523	30	116		0.25	0.11		
			3500	5802	48	121		0.40	0.17	-	
			4000	6045	46	130		0.39	0.17		
			5000	5784	48	121		0.40	0.17		
8SLSTPSC-UNV	080083174423	8	3500	4215	34	125	0-10V Dim to 10%	0.28	0.12	-	
			4000	4321	33	130		0.28	0.12		
			5000	4288	34	127		0.28	0.12		
			3500	7782	64	121		0.54	0.23		
			4000	8141	63	130		0.52	0.23		
			5000	7901	64	123		0.54	0.23		
			3500	10456	88	118		0.74	0.32		
			4000	11119	85	130		0.71	0.31		
			5000	10456	89	118		0.74	0.32	-	
			3500	2489	22	114		-	-		0.06
			4000	2631	21	125		-	-		0.06
2SLSTPSC-347	080083249442	2	5000	2538	22	117	0-10V Dim to 10%	-	-	0.06	
			3500	2339	18	127		-	-	0.05	
			4000	2446	18	134		-	-	0.05	
4SLSTPSC-347	080083249466	4	5000	2386	18	130	0-10V Dim to 10%	-	-	0.05	
			3500	3479	31	113		-	-	0.09	
			4000	3669	30	121		-	-	0.09	
			5000	3550	31	115		-	-	0.09	
			3500	5736	47	122		-	-	0.14	
			4000	6115	46	133		-	-	0.13	
			5000	5852	47	124		-	-	0.14	
			8SLSTPSC-347	080083249480	8	3500		4419	33	136	0-10V Dim to 10%
4000	4556	32				143	-	-	0.09		
5000	4521	32				140	-	-	0.09		
3500	7937	64				124	-	-	0.18		
4000	8325	62				134	-	-	0.18		
5000	8254	65				127	-	-	0.19		
3500	10622	87				123	-	-	0.25		
4000	11202	84				134	-	-	0.24		
5000	10692	86	124	-	-	0.25					

Energy Data - 120V

	2'	4'	8'
PF	0.99	0.99	0.99
THD%	< 8.5	< 9.9	< 8.1
Low Temp Start	-20°C	-20°C	-20°C

Shipping Data

Catalog Base	Wt. (lbs)	Unit per Pallet	Case Pack Qty.
2SLSTP	2.5	180	6
4SLSTP	4.5	120	4
8SLSTP	8	100	2



Factory Installed Mod Shop Option

Catalog	Emergency Battery Installed ^{(2), (4)}
2SLSTP* - ___	
4SLSTP* - ___	BSL6 = Bodine 6W Emergency
8SLSTP* - ___	BSL10 = Bodine 10W Emergency

Example: 4SLSTPSLC-UNV-BSL10

ROW ALIGNER 8' - 8' ROW ALIGNER 8' - 4'

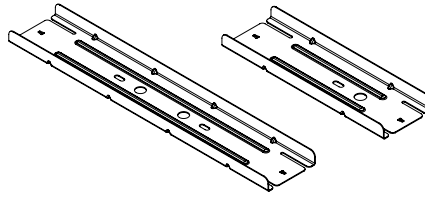

Accessories

- AVC-Chain/Set=36" Hanging Chain Set w/V Hooks
- Y-Toggle-10-2PK=(2) Y-Toggle Cable Kits at 10FT long ⁽¹⁾
- SCF-12-B=12" Fixed Stem Set (specify if another length is needed) ⁽¹⁾
- 2SLSTPLNS=2 ft. Replacement Lens
- 4SLSTPLNS=4 ft. Replacement Lens
- 8SLSTPLNS=8 ft. Replacement Lens
- EBPLED7W=User Installed, Remote Mount, 7 Watt LED Emergency Battery Pack
- EBPLED14W=User Installed, Remote Mount, 14 Watt LED Emergency Battery Pack
- SLSTPMS00 KIT=Field installable sensor kit, PIR Sensor 100% 50% OFF
- SLSTPMS25 KIT=Field installable sensor kit, PIR Sensor 100% 50% Low (~30%)
- SLSTPROW88=8ft to 8ft continuous row bracket
- SLSTPROW842=8ft to 4ft or 2ft continuous row bracket

Notes: (1) For stem, order two per fixture.
 (2) For approximate delivered lumens multiply the lumens per watt of the desired fixture by the wattage of the emergency battery pack (100 lm/W x 7-700 lumens).
 (3) Continuous row mount only between fixtures.
 (4) EBP not available at 347V

Catalog	Unit UPC	Unit Carton Qty	Case Qty
SLSTPROW88	080083815654	1	50
SLSTPROW842	080083815661	1	50

SLSTP MOTION SENSOR KIT (COMING SOON)

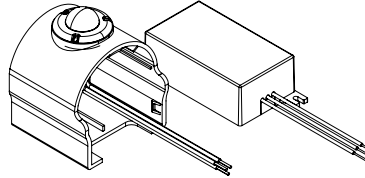

Catalog	Unit UPC	Unit Carton Qty	Case Qty
SLSTP MS00 Kit	080083254200	1	50
SLSTP MS25 Kit	080083254224	1	50

Product Specifications

Construction

- Fixture channel, cover and end plates are formed from cold rolled steel
- Decorative end caps snap-on for an improved aesthetic finish
- Suitable for either single or continuous row applications

Electrical

- Long-Life LED system with an energy-efficient electronic driver comes in UNV (120-277V) or 120/347V versions
- Available with 0-10V dimming
- CCT Selectable option for maximum color flexibility: choose from 3500K, 4000K or 5000K
- LED and Light Engine
 - Lumen select switch provides three lumen package choices (Low, Medium and High)
 - L70 at >50,000 hours (TM-21), over 23 years at 6 hrs/day
 - CRI 83 or better

Controls

- Maximize energy savings - combine with products like occupancy sensors, daylighting controls, and lighting relay panels
- Standard 0-10V continuous dimming driver works with any standard 0-10V control/dimmer
- Dimming range is 10% to 100% and varies by control device
- Purple and grey (pink) low voltage dimming leads required from 0-10V dimmer switch to fixture
- PIR occupancy sensors enables code compliance. Refer to accessory kit for setting levels.
- Sensor kit can be field installed. Add up to (20) 4ft or (10) 8ft fixtures per single sensor kit. Kit is end mount only.

Finish

- Post painted with high reflective paint – standard, for ease of handling

Shielding

- Frost, polycarbonate lens with linear prisms for uniform light distribution

Emergency Battery Pack Option

- Factory installed 120V-277V integral emergency battery pack available via mod-shop.
- 90-minute backup period for code compliance
- Factory installed integral test switch visible from row side

Installation

- May be surface, suspended, or wall mounted
- Multiple 7/8" K.O. on back and one on each end
- Jbox cover, wire nuts and decorative end caps included

Compliance

- cULus listed for damp location rated
- LED's comply with IESNA LM-79 and LM-80 standards
- DesignLights Consortium® Qualified and classified for DLC Standard, refer to www.designlights.org for details
- RoHS compliant
- Suitable for use in closet storage spaces when installed in accordance with NFPA-70 and NEC 410.16 spacing requirements

Warranty

- Five year limited warranty



Photometric Data

[View IES files](#)

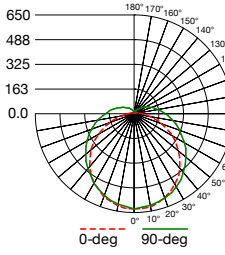

4SLSTPSLC-UNV
 Electronic Driver
 Linear LED 4000K
 Spacing criterion: (II) 1.28 x mounting height, (⊥) 1.32 x mounting height
 Lumens: 2418
 Input Watts: 17.6W
 Efficacy: 137 LPW
 Test Report: 4SLSTPSLC-UNV-LO-4000K.IES

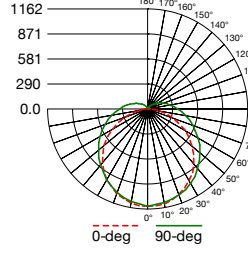

8SLSTPSLC-UNV
 Electronic Driver
 Linear LED 4000K
 Spacing criterion: (II) 1.28 x mounting height, (⊥) 1.32 x mounting height
 Lumens: 4321
 Input Watts: 33.2W
 Efficacy: 130 LPW
 Test Report: 8SLSTPSLC-UNV-LO-4000K.IES

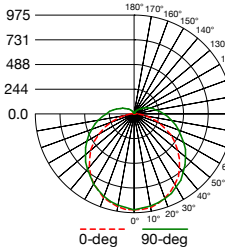

4SLSTPSLC-UNV
 Electronic Driver
 Linear LED 4000K
 Spacing criterion: (II) 1.28 x mounting height, (⊥) 1.32 x mounting height
 Lumens: 3627
 Input Watts: 29.7W
 Efficacy: 122 LPW
 Test Report: 4SLSTPSLC-UNV-MID-4000K.IES

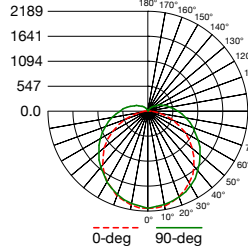

8SLSTPSLC-UNV
 Electronic Driver
 Linear LED 4000K
 Spacing criterion: (II) 1.28 x mounting height, (⊥) 1.32 x mounting height
 Lumens: 8141
 Input Watts: 62.5W
 Efficacy: 130 LPW
 Test Report: 8SLSTPSLC-UNV-MID-4000K.IES

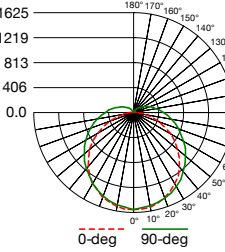

4SLSTPSLC-UNV
 Electronic Driver
 Linear LED 4000K
 Spacing criterion: (II) 1.28 x mounting height, (⊥) 1.32 x mounting height
 Lumens: 6045
 Input Watts: 46.4W
 Efficacy: 130 LPW
 Test Report: 4SLSTPSLC-UNV-HI-4000K.IES

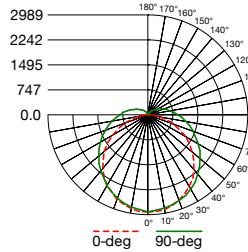

8SLSTPSLC-UNV
 Electronic Driver
 Linear LED 4000K
 Spacing criterion: (II) 1.28 x mounting height, (⊥) 1.32 x mounting height
 Lumens: 11119
 Input Watts: 85.4W
 Efficacy: 130 LPW
 Test Report: 8SLSTPSLC-UNV-HI-4000K.IES

Mounting Dimensions

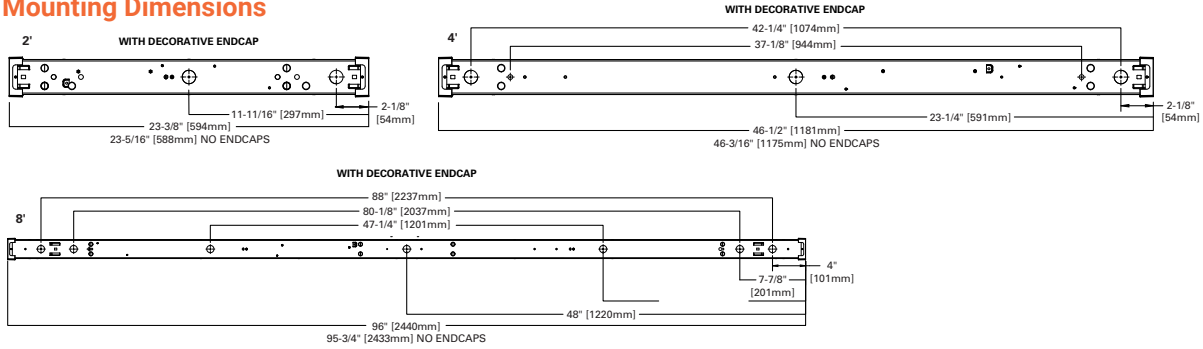

Overall Dimensions

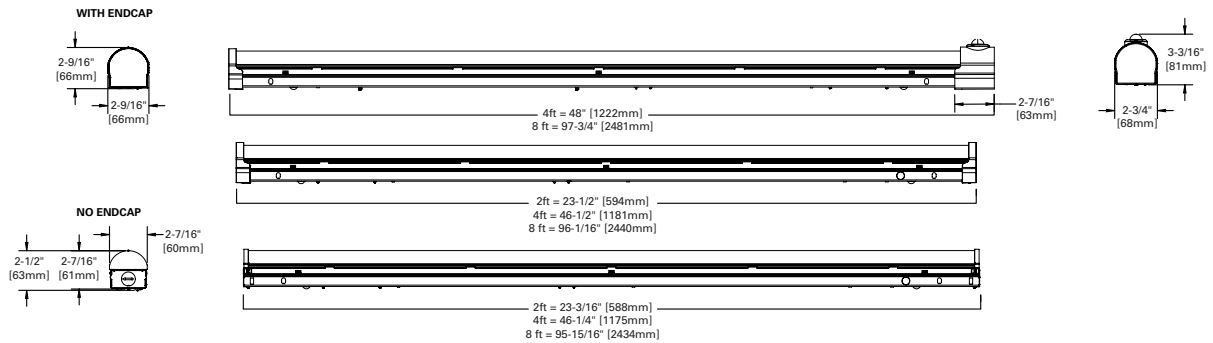

Sensor Coverage (MS Sensor Kit)

SENSOR COVERAGE PATTERN - TOP VIEW

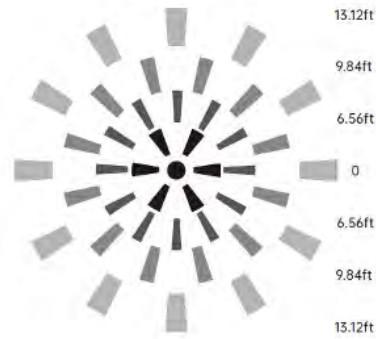

SIDE VIEW

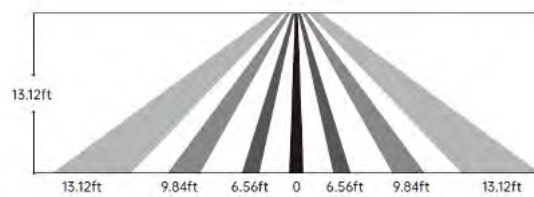

LIGHT OUTPUT OVER TIME

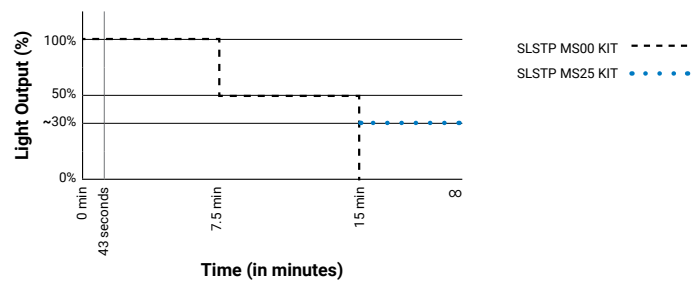

Project		Catalog #		Type	
Prepared by		Notes		Date	

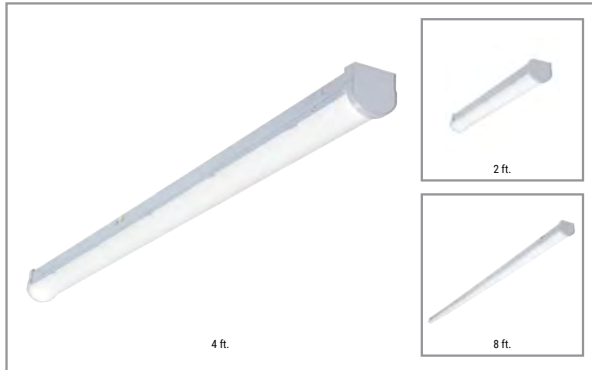

Metalux

SLSTP Lensed LED

Selectable CCT and Lumen LED Striplight

Typical Applications
Commercial • Industrial • Retail • Residential

Interactive Menu

- Order Information [page 2](#)
- Photometric Data [page 4](#)
- Sensor Coverage [page 5](#)
- Product Warranty

Product Certification



Product Features



Top Product Features

- External selectable switches provide easy, in field customization
- (3) color temperature and lumen select option provide application versatility
- Single frost lens (no breaks) provides clean, continuous lighting layout
- Up to 143 LPW and DLC compliant to enable rebates and energy savings
- Available in 8ft, 4ft and 2ft lengths, single and continuous mount capable
- UNV and 347V driver with 0-10V dimming, 10% standard
- Jbox cover, decorative endcap included to complete install.

Dimensional and Mounting Details

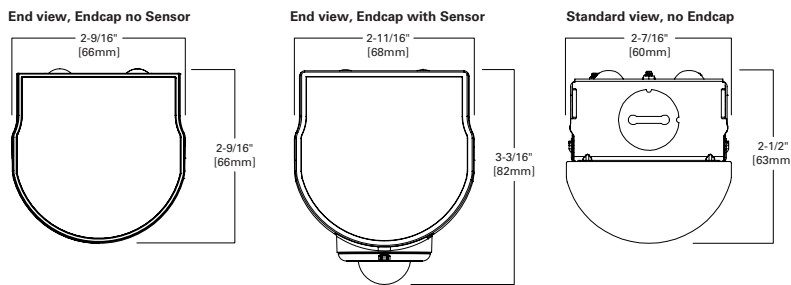

[additional product diagrams](#)



PS51969122 page 1
September 20, 2022 7:56 AM



Catalog Information: 4SLSTPSLC-UNV

Date:01/27/2023
Fixture Type:

B3A

Order Information and Performance Data

Catalog #	UPC	Length	CCT (K)	Delivered Lumens	Watts	Efficacy (lm/W)	Dimming (Triac or 0-10V)	Input Current (A)			
								120V	277V	347V	
2SLSTPSC-UNV	080083174409	2	3500	2445	22	113	0-10V Dim to 10%	0.18	0.08	-	
			4000	2585	21	123		0.17	0.08		
			5000	2470	21	115		0.18	0.08		
			3500	2416	18	133		0.15	0.07	-	
			4000	2418	18	137		0.15	0.06		
			5000	2383	18	134		0.15	0.06		
4SLSTPSC-UNV	080083174416	4	3500	3534	31	115	0-10V Dim to 10%	0.26	0.11	-	
			4000	3627	30	122		0.25	0.11		
			5000	3523	30	116		0.25	0.11		
			3500	5802	48	121		0.40	0.17	-	
			4000	6045	46	130		0.39	0.17		
			5000	5784	48	121		0.40	0.17		
8SLSTPSC-UNV	080083174423	8	3500	4215	34	125	0-10V Dim to 10%	0.28	0.12	-	
			4000	4321	33	130		0.28	0.12		
			5000	4288	34	127		0.28	0.12		
			3500	7782	64	121		0.54	0.23		
			4000	8141	63	130		0.52	0.23		
			5000	7901	64	123		0.54	0.23		
			3500	10456	88	118		0.74	0.32		
			4000	11119	85	130		0.71	0.31		
			5000	10456	89	118		0.74	0.32	-	
			3500	2489	22	114		-	-		0.06
			4000	2631	21	125		-	-		0.06
			5000	2538	22	117		-	-	0.06	
			3500	2339	18	127		-	-	0.05	
			4000	2446	18	134		-	-	0.05	
4SLSTPSC-347	080083249466	4	5000	2386	18	130	0-10V Dim to 10%	-	-	0.05	
			3500	3479	31	113		-	-	0.09	
			4000	3669	30	121		-	-	0.09	
			5000	3550	31	115		-	-	0.09	
			3500	5736	47	122		-	-	0.14	
			4000	6115	46	133		-	-	0.13	
			5000	5852	47	124		-	-	0.14	
			3500	4419	33	136		-	-	0.09	
8SLSTPSC-347	080083249480	8	4000	4556	32	143	0-10V Dim to 10%	-	-	0.09	
			5000	4521	32	140		-	-	0.09	
			3500	7937	64	124		-	-	0.18	
			4000	8325	62	134		-	-	0.18	
			5000	8254	65	127		-	-	0.19	
			3500	10622	87	123		-	-	0.25	
			4000	11202	84	134		-	-	0.24	
			5000	10692	86	124		-	-	0.25	

Energy Data - 120V

	2'	4'	8'
PF	0.99	0.99	0.99
THD%	< 8.5	< 9.9	< 8.1
Low Temp Start	-20°C	-20°C	-20°C

Shipping Data

Catalog Base	Wt. (lbs)	Unit per Pallet	Case Pack Qty.
2SLSTP	2.5	180	6
4SLSTP	4.5	120	4
8SLSTP	8	100	2



Catalog Information: 4SLSTPSC-UNV

Date:01/27/2023
Fixture Type:

B3A

Factory Installed Mod Shop Option

Catalog	Emergency Battery Installed ^{(2), (4)}
2SLSTP* - ___	BSL6 = Bodine 6W Emergency BSL10 = Bodine 10W Emergency
4SLSTP* - ___	
8SLSTP* - ___	

Example: 4SLSTPSLC-UNV-BSL10

ROW ALIGNER 8' - 8' ROW ALIGNER 8' - 4'

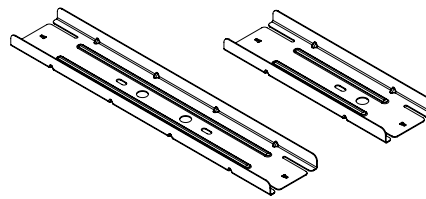

Accessories

AVC-Chain/Set=36" Hanging Chain Set w/V Hooks
Y-Toggle-10-2PK=(2) Y-Toggle Cable Kits at 10FT long ⁽¹⁾
SCF-12-8-12" Fixed Stem Set (specify if another length is needed) ⁽¹⁾
2SLSTPLNS=2 ft. Replacement Lens
4SLSTPLNS=4 ft. Replacement Lens
8SLSTPLNS=8 ft. Replacement Lens
EBPLED7W=User Installed, Remote Mount, 7 Watt LED Emergency Battery Pack
EBPLED14W=User Installed, Remote Mount, 14 Watt LED Emergency Battery Pack
SLSTPMS00 KIT=Field installable sensor kit, PIR Sensor 100% 50% OFF
SLSTPMS25 KIT=Field installable sensor kit, PIR Sensor 100% 50% Low (~30%)
SLSTPROW88=8ft to 8ft continuous row bracket
SLSTPROW842=8ft to 4ft or 2ft continuous row bracket

Notes: (1) For stem, order two per fixture.
 (2) For approximate delivered lumens multiply the lumens per watt of the desired fixture by the wattage of the emergency battery pack (100 lm/W x 7-700 lumens).
 (3) Continuous row mount only between fixtures.
 (4) EBP not available at 347V

Catalog	Unit UPC	Unit Carton Qty	Case Qty
SLSTPROW88	080083815654	1	50
SLSTPROW842	080083815661	1	50

SLSTP MOTION SENSOR KIT (COMING SOON)

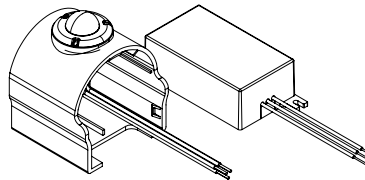

Catalog	Unit UPC	Unit Carton Qty	Case Qty
SLSTP MS00 Kit	080083254200	1	50
SLSTP MS25 Kit	080083254224	1	50

Product Specifications

Construction

- Fixture channel, cover and end plates are formed from cold rolled steel
- Decorative end caps snap-on for an improved aesthetic finish
- Suitable for either single or continuous row applications

Electrical

- Long-Life LED system with an energy-efficient electronic driver comes in UNV (120-277V) or 120/347V versions
- Available with 0-10V dimming
- CCT Selectable option for maximum color flexibility: choose from 3500K, 4000K or 5000K
- LED and Light Engine
 - Lumen select switch provides three lumen package choices (Low, Medium and High)
 - L70 at >50,000 hours (TM-21), over 23 years at 6 hrs/day
 - CRI 83 or better

Controls

- Maximize energy savings - combine with products like occupancy sensors, daylighting controls, and lighting relay panels
- Standard 0-10V continuous dimming driver works with any standard 0-10V control/dimmer
- Dimming range is 10% to 100% and varies by control device
- Purple and grey (pink) low voltage dimming leads required from 0-10V dimmer switch to fixture
- PIR occupancy sensors enables code compliance. Refer to accessory kit for setting levels.
- Sensor kit can be field installed. Add up to (20) 4ft or (10) 8ft fixtures per single sensor kit. Kit is end mount only.

Finish

- Post painted with high reflective paint – standard, for ease of handling

Shielding

- Frost, polycarbonate lens with linear prisms for uniform light distribution

Emergency Battery Pack Option

- Factory installed 120V-277V integral emergency battery pack available via mod-shop.
- 90-minute backup period for code compliance
- Factory installed integral test switch visible from row side

Installation

- May be surface, suspended, or wall mounted
- Multiple 7/8" K.O. on back and one on each end
- Jbox cover, wire nuts and decorative end caps included

Compliance

- cULus listed for damp location rated
- LED's comply with IESNA LM-79 and LM-80 standards
- DesignLights Consortium® Qualified and classified for DLC Standard, refer to www.designlights.org for details
- RoHS compliant
- Suitable for use in closet storage spaces when installed in accordance with NFPA-70 and NEC 410.16 spacing requirements

Warranty

- Five year limited warranty

Photometric Data

[View IES files](#)

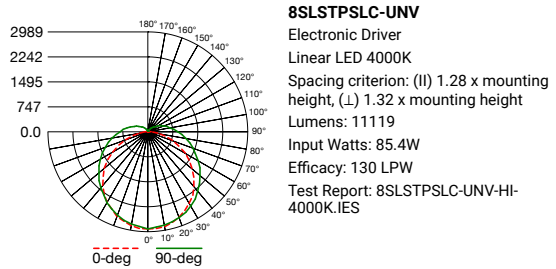
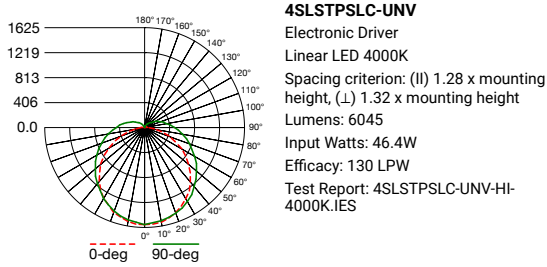
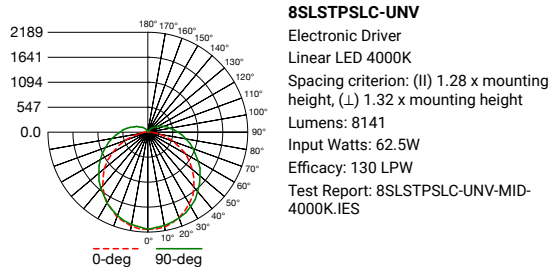
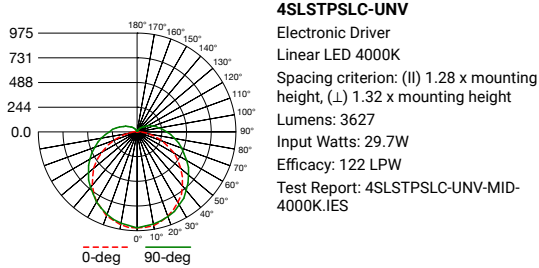
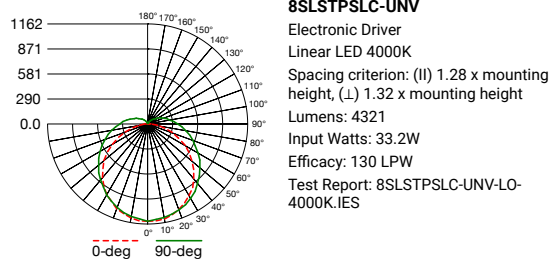
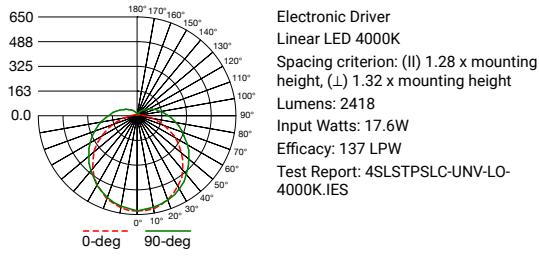

Mounting Dimensions

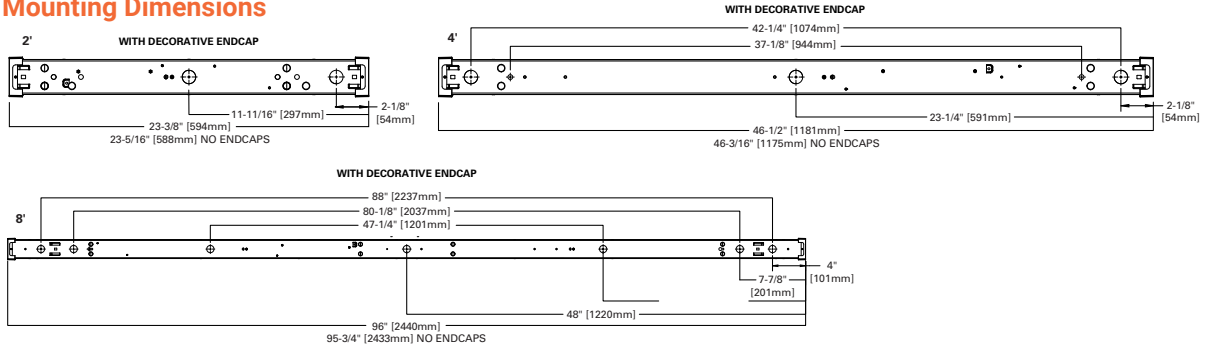

Overall Dimensions

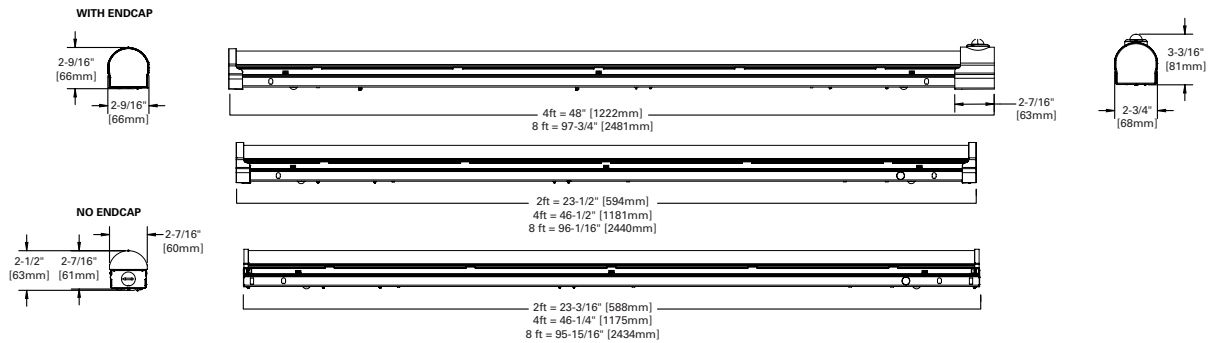

Sensor Coverage (MS Sensor Kit)

SENSOR COVERAGE PATTERN - TOP VIEW

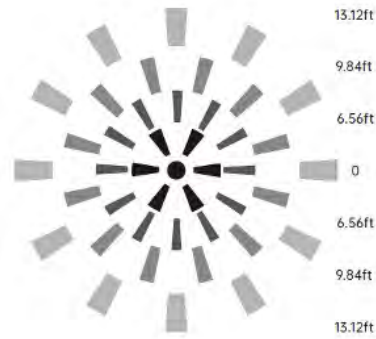

SIDE VIEW

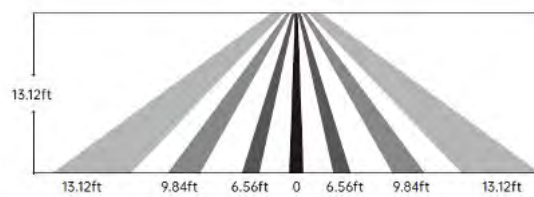

LIGHT OUTPUT OVER TIME

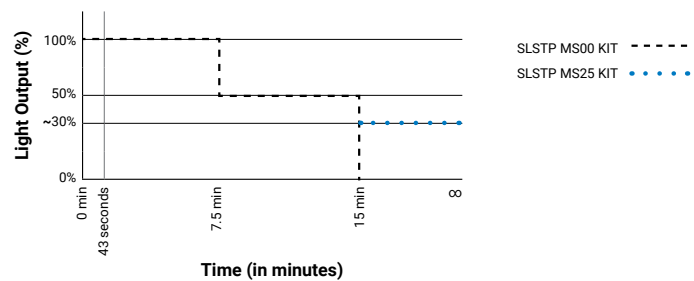

Project		Catalog #		Type	
Prepared by		Notes		Date	

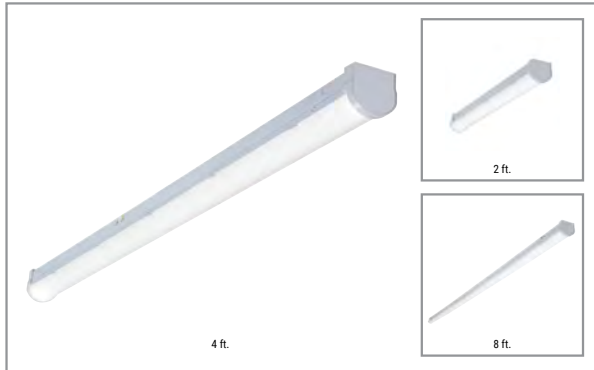

Metalux

SLSTP Lensed LED

Selectable CCT and Lumen LED Striplight

Typical Applications

Commercial • Industrial • Retail • Residential

Interactive Menu

- Order Information [page 2](#)
- Photometric Data [page 4](#)
- Sensor Coverage [page 5](#)
- Product Warranty

Product Certification



Product Features



Top Product Features

- External selectable switches provide easy, in field customization
- (3) color temperature and lumen select option provide application versatility
- Single frost lens (no breaks) provides clean, continuous lighting layout
- Up to 143 LPW and DLC compliant to enable rebates and energy savings
- Available in 8ft, 4ft and 2ft lengths, single and continuous mount capable
- UNV and 347V driver with 0-10V dimming, 10% standard
- Jbox cover, decorative endcap included to complete install.

Dimensional and Mounting Details

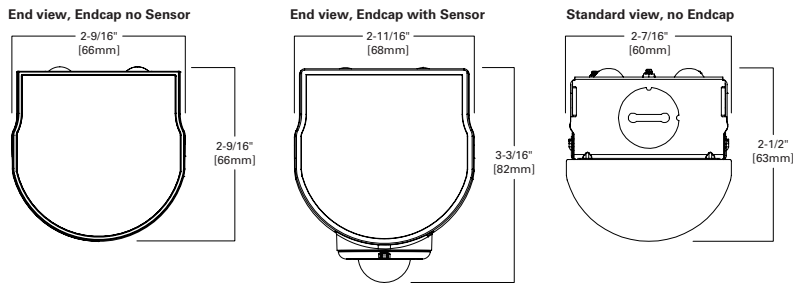

[additional product diagrams](#)



PS51969122 page 1
September 20, 2022 7:56 AM



Catalog Information: 4SLSTPSLC-UNV-BSL10

Date:01/27/2023
Fixture Type:

B3A-EM

Order Information and Performance Data

Catalog #	UPC	Length	CCT (K)	Delivered Lumens	Watts	Efficacy (lm/W)	Dimming (Triac or 0-10V)	Input Current (A)			
								120V	277V	347V	
2SLSTPSC-UNV	080083174409	2	3500	2445	22	113	0-10V Dim to 10%	0.18	0.08	-	
			4000	2585	21	123		0.17	0.08		
			5000	2470	21	115		0.18	0.08		
			3500	2416	18	133		0.15	0.07	-	
			4000	2418	18	137		0.15	0.06		
			5000	2383	18	134		0.15	0.06		
4SLSTPSC-UNV	080083174416	4	3500	3534	31	115	0-10V Dim to 10%	0.26	0.11	-	
			4000	3627	30	122		0.25	0.11		
			5000	3523	30	116		0.25	0.11		
			3500	5802	48	121		0.40	0.17	-	
			4000	6045	46	130		0.39	0.17		
			5000	5784	48	121		0.40	0.17		
8SLSTPSC-UNV	080083174423	8	3500	4215	34	125	0-10V Dim to 10%	0.28	0.12	-	
			4000	4321	33	130		0.28	0.12		
			5000	4288	34	127		0.28	0.12		
			3500	7782	64	121		0.54	0.23		
			4000	8141	63	130		0.52	0.23		
			5000	7901	64	123		0.54	0.23		
			3500	10456	88	118		0.74	0.32		
			4000	11119	85	130		0.71	0.31		
			5000	10456	89	118		0.74	0.32	-	
			3500	2489	22	114		-	-		0.06
			4000	2631	21	125		-	-		0.06
2SLSTPSC-347	080083249442	2	5000	2538	22	117	0-10V Dim to 10%	-	-	0.06	
			3500	2339	18	127		-	-	0.05	
			4000	2446	18	134		-	-	0.05	
4SLSTPSC-347	080083249466	4	5000	2386	18	130	0-10V Dim to 10%	-	-	0.05	
			3500	3479	31	113		-	-	0.09	
			4000	3669	30	121		-	-	0.09	
			5000	3550	31	115		-	-	0.09	
			3500	5736	47	122		-	-	0.14	
			4000	6115	46	133		-	-	0.13	
			5000	5852	47	124		-	-	0.14	
			8SLSTPSC-347	080083249480	8	3500		4419	33	136	0-10V Dim to 10%
4000	4556	32				143	-	-	0.09		
5000	4521	32				140	-	-	0.09		
3500	7937	64				124	-	-	0.18		
4000	8325	62				134	-	-	0.18		
5000	8254	65				127	-	-	0.19		
3500	10622	87				123	-	-	0.25		
4000	11202	84				134	-	-	0.24		
5000	10692	86	124	-	-	0.25					

Energy Data - 120V

	2'	4'	8'
PF	0.99	0.99	0.99
THD%	< 8.5	< 9.9	< 8.1
Low Temp Start	-20°C	-20°C	-20°C

Shipping Data

Catalog Base	Wt. (lbs)	Unit per Pallet	Case Pack Qty.
2SLSTP	2.5	180	6
4SLSTP	4.5	120	4
8SLSTP	8	100	2



Factory Installed Mod Shop Option

Catalog	Emergency Battery Installed ^{(2), (4)}
2SLSTP* - ___	
4SLSTP* - ___	BSL 6 = Bodine 6W Emergency
8SLSTP* - ___	BSL10 = Bodine 10W Emergency

Example: 4SLSTPSLC-UNV-BSL10

ROW ALIGNER 8' - 8' **ROW ALIGNER 8' - 4'**

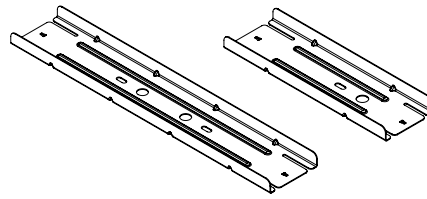

Accessories

- AVC-Chain/Set=36" Hanging Chain Set w/V Hooks
- Y-Toggle-10-2PK=(2) Y-Toggle Cable Kits at 10FT long ⁽¹⁾
- SCF-12-B=12" Fixed Stem Set (specify if another length is needed) ⁽¹⁾
- 2SLSTPLNS=2 ft. Replacement Lens
- 4SLSTPLNS=4 ft. Replacement Lens
- 8SLSTPLNS=8 ft. Replacement Lens
- EBPLED7W=User Installed, Remote Mount, 7 Watt LED Emergency Battery Pack
- EBPLED14W=User Installed, Remote Mount, 14 Watt LED Emergency Battery Pack
- SLSTPMS00 KIT=Field installable sensor kit, PIR Sensor 100% 50% OFF
- SLSTPMS25 KIT=Field installable sensor kit, PIR Sensor 100% 50% Low (~30%)
- SLSTPROW88=8ft to 8ft continuous row bracket
- SLSTPROW842=8ft to 4ft or 2ft continuous row bracket

Notes: (1) For stem, order two per fixture.
 (2) For approximate delivered lumens multiply the lumens per watt of the desired fixture by the wattage of the emergency battery pack (100 lm/W x 7-700 lumens).
 (3) Continuous row mount only between fixtures.
 (4) EBP not available at 347V

Catalog	Unit UPC	Unit Carton Qty	Case Qty
SLSTPROW88	080083815654	1	50
SLSTPROW842	080083815661	1	50

SLSTP MOTION SENSOR KIT (COMING SOON)

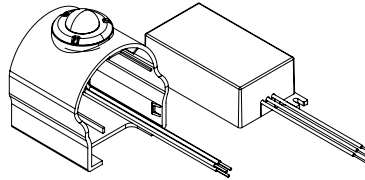

Catalog	Unit UPC	Unit Carton Qty	Case Qty
SLSTP MS00 Kit	080083254200	1	50
SLSTP MS25 Kit	080083254224	1	50

Product Specifications

Construction

- Fixture channel, cover and end plates are formed from cold rolled steel
- Decorative end caps snap-on for an improved aesthetic finish
- Suitable for either single or continuous row applications

Electrical

- Long-Life LED system with an energy-efficient electronic driver comes in UNV (120-277V) or 120/347V versions
- Available with 0-10V dimming
- CCT Selectable option for maximum color flexibility: choose from 3500K, 4000K or 5000K
- LED and Light Engine
 - Lumen select switch provides three lumen package choices (Low, Medium and High)
 - L70 at >50,000 hours (TM-21), over 23 years at 6 hrs/day
 - CRI 83 or better

Controls

- Maximize energy savings - combine with products like occupancy sensors, daylighting controls, and lighting relay panels
- Standard 0-10V continuous dimming driver works with any standard 0-10V control/dimmer
- Dimming range is 10% to 100% and varies by control device
- Purple and grey (pink) low voltage dimming leads required from 0-10V dimmer switch to fixture
- PIR occupancy sensors enables code compliance. Refer to accessory kit for setting levels.
- Sensor kit can be field installed. Add up to (20) 4ft or (10) 8ft fixtures per single sensor kit. Kit is end mount only.

Finish

- Post painted with high reflective paint – standard, for ease of handling

Shielding

- Frost, polycarbonate lens with linear prisms for uniform light distribution

Emergency Battery Pack Option

- Factory installed 120V-277V integral emergency battery pack available via mod-shop.
- 90-minute backup period for code compliance
- Factory installed integral test switch visible from row side

Installation

- May be surface, suspended, or wall mounted
- Multiple 7/8" K.O. on back and one on each end
- Jbox cover, wire nuts and decorative end caps included

Compliance

- cULus listed for damp location rated
- LED's comply with IESNA LM-79 and LM-80 standards
- DesignLights Consortium® Qualified and classified for DLC Standard, refer to www.designlights.org for details
- RoHS compliant
- Suitable for use in closet storage spaces when installed in accordance with NFPA-70 and NEC 410.16 spacing requirements

Warranty

- Five year limited warranty



Photometric Data

[View IES files](#)

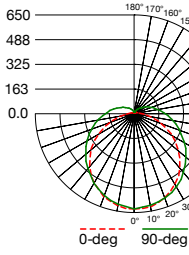

4SLSTPSLC-UNV
 Electronic Driver
 Linear LED 4000K
 Spacing criterion: (H) 1.28 x mounting height, (L) 1.32 x mounting height
 Lumens: 2418
 Input Watts: 17.6W
 Efficacy: 137 LPW
 Test Report: 4SLSTPSLC-UNV-LO-4000K.IES

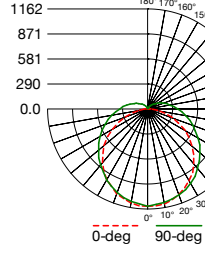

8SLSTPSLC-UNV
 Electronic Driver
 Linear LED 4000K
 Spacing criterion: (H) 1.28 x mounting height, (L) 1.32 x mounting height
 Lumens: 4321
 Input Watts: 33.2W
 Efficacy: 130 LPW
 Test Report: 8SLSTPSLC-UNV-LO-4000K.IES

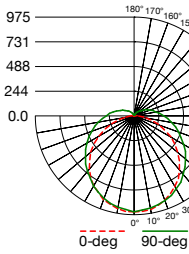

4SLSTPSLC-UNV
 Electronic Driver
 Linear LED 4000K
 Spacing criterion: (H) 1.28 x mounting height, (L) 1.32 x mounting height
 Lumens: 3627
 Input Watts: 29.7W
 Efficacy: 122 LPW
 Test Report: 4SLSTPSLC-UNV-MID-4000K.IES

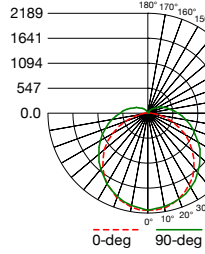

8SLSTPSLC-UNV
 Electronic Driver
 Linear LED 4000K
 Spacing criterion: (H) 1.28 x mounting height, (L) 1.32 x mounting height
 Lumens: 8141
 Input Watts: 62.5W
 Efficacy: 130 LPW
 Test Report: 8SLSTPSLC-UNV-MID-4000K.IES

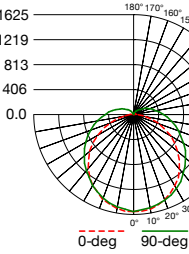

4SLSTPSLC-UNV
 Electronic Driver
 Linear LED 4000K
 Spacing criterion: (H) 1.28 x mounting height, (L) 1.32 x mounting height
 Lumens: 6045
 Input Watts: 46.4W
 Efficacy: 130 LPW
 Test Report: 4SLSTPSLC-UNV-HI-4000K.IES

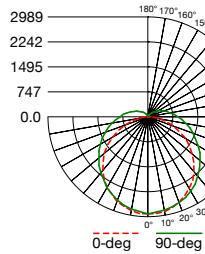

8SLSTPSLC-UNV
 Electronic Driver
 Linear LED 4000K
 Spacing criterion: (H) 1.28 x mounting height, (L) 1.32 x mounting height
 Lumens: 11119
 Input Watts: 85.4W
 Efficacy: 130 LPW
 Test Report: 8SLSTPSLC-UNV-HI-4000K.IES



Mounting Dimensions

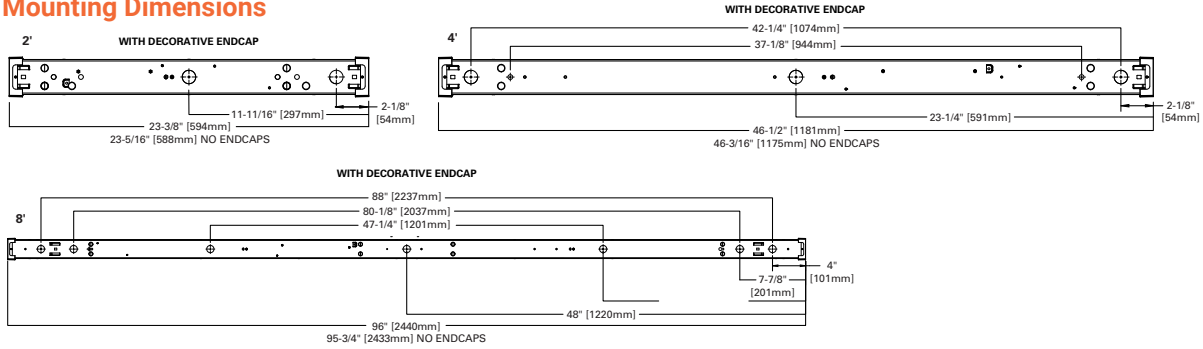

Overall Dimensions

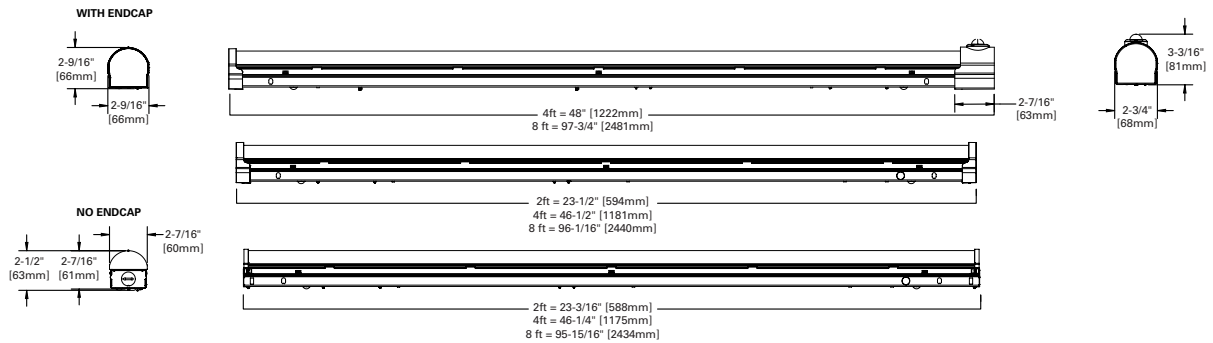

Sensor Coverage (MS Sensor Kit)

SENSOR COVERAGE PATTERN - TOP VIEW

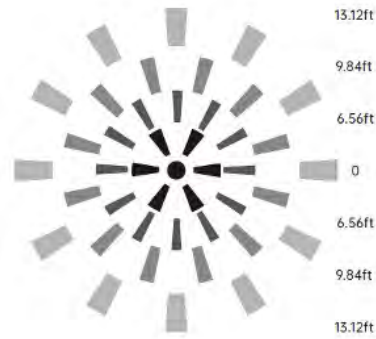

SIDE VIEW

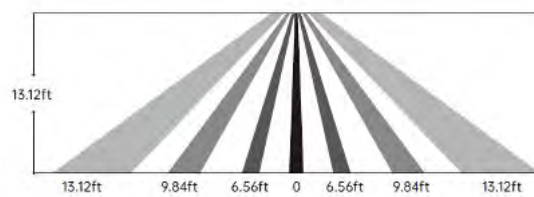

LIGHT OUTPUT OVER TIME

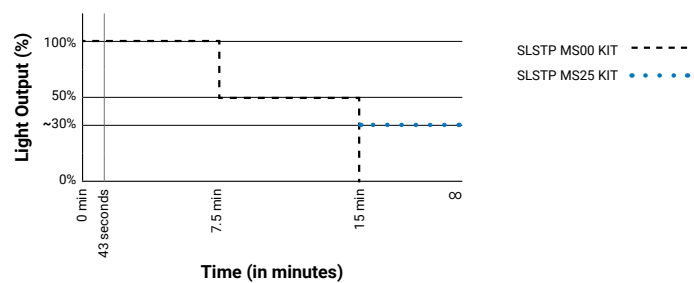

MARK
ARCHITECTURAL
LIGHTING™

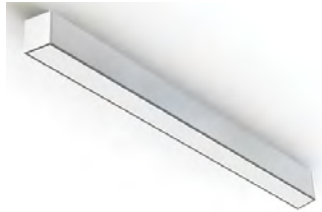

Slot 4 LED
Surface Mount

The Slot LED family of luminaires offers an unparalleled package of performance and features for your next lighting project. Precision lumen DIRECTIR optics deliver optimized light where needed for ceilings and walls. With other key features such as simplified installation, seamless controls integration and superior LED color constancy, the Slot LED family from Mark Lighting offers exceptional quality and design flexibility.

Type:

Project:

Catalog Number:

DO NOT TYPE HERE. Autopopulated field.

Specification Features

Housing

Nominal 3.5" x 3.75" extruded aluminum housing

Finish

White, Black or Silver powdercoat

Reflector

Formed steel with high reflectance white.

Distribution/Shielding

Extruded 90% transmissive acrylic lens with a textured surface providing diffuse illumination and a uniform appearance for direct lambertian distribution (No Optics). Wall Wash (WW) and Wall Graze (WG) distribution options incorporate co-extruded lenses. Shielding is available as an external blade louver for WW or WG options, or an internal blade louver in lieu of lambertian distribution diffuser.

LED Components

Linear: Nichia®- 757 series LED chips (>80 CRI)

Electrical

Long-life LEDs, coupled with high-efficiency drivers, provide superior quantity and quality of illumination for extended service life. 80% LED lumen maintenance at 60,000 hours (L80/60,000).

Color Consistency

The Acuity Brands circuit boards for the linear LED components use a precise binning algorithm which creates a consistent color temperature from board to board. The color a variation of no greater than a 2.5 Step MacAdam (2.5SDCM) along the black body locus from board to board.

Driver

Factory tuned constant current electronic dimming driver is standard. Flicker free dimming available down to <1%. LED drivers perform within the recommended operating areas for flicker as a function of frequency and modulation (%) IEEE Standard 1789-2015 (IEEE Recommended Practices for Modulating Current in High-Brightness LEDs for Mitigating Health Risks to Viewers), in typical operating conditions at representative dimming levels. Electrical specifications at maximum driver load: PF > 0.9 and THD <20%. Meets FCC Title 47 Class A or Class B. Other available drivers include Lutron, DMX and DALI protocol drivers.

Certification

CSA tested to UL 1598 standards, assembled in the USA. Damp location listed.

Listings

DesignLights Consortium® (DLC) Premium qualified product. Not all versions of this product may be DLC Premium qualified. Please check the DLC Qualified Products List at www.designlights.org/OPL to confirm which versions are qualified.

Warranty

5-year limited warranty. Complete warranty terms located at: www.acuitybrands.com/support/warranty/terms-and-conditions

Note: Actual performance may differ as a result of end-user environment and application.

All values are design or typical values, measured under laboratory conditions at 25 °C.

Specifications subject to change without notice.

Fixture Performance

4FT INDIVIDUAL (35K)	DIRECT			
	400LMF	600LMF	800LMF	1000LMF
Delivered Lumens	1800	2707	3571	4103
Input Watts	15.4	23.4	32	37.3
Lumen/Watt	117	115	112	110

* Consult factory for customized lumen output and wattage between 350LMF and 1050LMF.

Technical Drawing

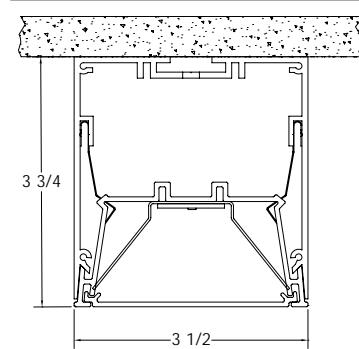

Direct Surface



eldoLED
your product our drive

Declare.



Buy American



Buy American:

Product with the BAA option is assembled in the USA and meets the Buy America(n) government procurement requirements under FAR, DFARS and DOT. Please refer to www.acuitybrands.com/buy-american for additional information.

A+ Capable Luminaire

This item is an A+ capable luminaire, which has been designed and tested to provide consistent color appearance and out-of-the-box control compatibility with simple commissioning.

- All configurations of this luminaire meet the Acuity Brands' specification for chromatic consistency
- This luminaire is part of an A+ Certified solution for nLight® control networks when ordered with drivers marked by a shaded background*
- This luminaire is part of an A+ Certified solution for nLight control networks, providing advanced control functionality at the luminaire level, when selection includes driver and control options marked by a shaded background*

To learn more about A+, visit www.acuitybrands.com/aplus.

*See ordering tree for details



Catalog
Information:

S4LS-LLP-8FT-MSL8-90CRI-35K-1000LMF-MIN1-MVOLT-
[FINISH]-ZT

Date:01/27/2023
Fixture Type:

B4

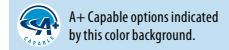

Ordering

Example: S4LS 32FT MSL8 90CRI 40K 1000LMF DARK EGLD 120 WHT ZT

Series	Plan	Total Run Length	Max Section Length	Direct Light Source Color Rendering	Direct LED Color Temp	Direct LED Light Output	Direct Distribution (Optics)
S4LS Slot 4 Surface - Direct	LCB Linear center balanced LLP Linear longest possible	8FT Specify continuous run length (in whole feet, 2' minimum). Unit length may affect available options. 2' & 3' only available as individual units. For runs longer than 8FT: ALWAYS order the run by the TOTAL RUN LENGTH. Ordering the sections individually will not provide the correct joining hardware to allow connection in the field.	MSL4 4' MSL5 5' MSL6 6' MSL7 7' MSL8 8'	80CRI 80 CRI 90CRI 90 CRI	27K 2700K 30K 3000K 35K 3500K 40K 4000K 50K 5000K	400LMF 400 lumens per FT 600LMF 600 lumens per FT 800LMF 800 lumens per FT 1000LMF 1000 lumens per FT _LMF¹ # lumens per FT	(blank) Standard lambertian distribution WW² Wallwash distributions WG Wall graze distribution WW and WG not available with Downlights, EGLD, LVRR or LVRRRA.

Downlight	Downlight Shape	Downlight Color Rendering	Downlight Color Temp	Minimum Dimming Level	Optional Shielding	Voltage
(blank) No Downlight modules in fixture 2DL LED downlights (2 per unit) _DL LED downlights per run (3DL, 4DL, etc.)	(blank) No downlight modules in fixture RDD Round SQD Square	(blank) No downlight modules in fixture S80CRI 80 CRI	(blank) No downlight modules in fixture S27K 2700K S30K 3000K S35K 3500K S40K 4000K	NODIM³ Non-dimming MIN1 Constant current, dimming to 1% DARK Constant current, dimming to 0.1%	(blank) No louver LVRD⁴ Dropped louver LVRR⁵ Regressed louver painted to match fixture finish LVRRRA⁶ Regressed louver, aluminum finish EGLD^{4,5} Edge View direct lens Not available with Downlights. Not available with NLTAIR2.	MVOLT Multi-volt, 120-277V 120 120V 277 277V 347⁷ 347V

Finish	Emergency Options	Control Input	Sensor	Secondary Sensor
WHT White (gloss) BLK Black (gloss) SLV Silver (gloss) WHHT White (textured) BLKT Black (textured) SLVT Silver (textured) RALTB RAL paint finishes	E10WLCP⁸ 4' emergency section w/ battery pack, 1250 lumens _E10WLCP⁸ 4' emergency section w/ battery pack, 1250 lumens _EC⁹ # of emergency circuits BGTD^{9,10} Generator transfer device Not available with 347V.	(blank) Non-dimming, line voltage ZT 0-10V control NLIGHT¹¹ nLight enabled NLTAIR2¹² nLight AIR (wireless) enabled DALI^{13,14} DALI compatible DMX^{13,14} DMX compatible ECOD^{14,15} Lutron Hi-Lume digital driver ECOD2^{14,15,16} Lutron Hi-Lume 2-wire (1% dimming) ECOD5^{14,15} Lutron 5-series digital driver (5% dimming)	(blank) Select if single zone/no zone without sensor NS Select if multi-zone fixture with no sensor in main zone PDT¹⁷ Occupancy sensor - dual technology (passive infrared & microphonic) ADC¹⁷ Photocell-daylight dimming sensor API¹⁸ PIR occupancy sensor & photocell APD¹⁸ PDT occupancy sensor & photocell Not available with Downlights. Not available with 347V & nLight. (Use ZT or NLTAIR2 Control Inputs where applicable.) Not available on 2' or 3' units.	(blank) No additional zones/sensors SNS Select if multi-zone fixture with no sensor in secondary zone SPDT¹⁷ Occupancy sensor - dual technology (passive infrared & microphonic) SADC¹⁷ Photocell-daylight dimming sensor SAPI¹⁸ PIR occupancy sensor & photocell SAPD¹⁸ PDT occupancy sensor & photocell Not available with Downlights. Not available with 347V & nLight. (Use ZT or NLTAIR2 Control Inputs where applicable.) Not available on 2' or 3' units.

Tertiary Sensor	Options
(blank) No additional zones/sensors TNS Select if multi-zone fixture with no sensor in tertiary zone	BAA Buy America(n) Compliant GLR¹⁴ Fast-blow fuse GMF¹⁴ Slow-blow fuse WL¹⁴ Wet Location

Notes:

- Limited to 350LMF to 1050LMF in 50LMF increments. Not available with ECOD, ECOD2, ECOD5 or DMX control input.
- Not available with NLTAIR2.
- Not available with Control Input.
- Not available with Sensor Options.
- Not available with Emergency Options.
- Not available with sensors on 2', 3' & 4' units.
- Not available with ZT & sensors, with NLTAIR2, with emergency options, with NLIGHT in 5' units, with NLIGHT & downlights.
- Not available with 2' or 3' units. Not available with DMX control option. One battery pack per unit. Only available on 8' unit with ECOD, ECOD2, ECOD5. Not available on 5' unit with NLTAIR. If with ZT & API, APD, or NLTAIR2 only available in 7' & 8' units.
- Powers entire direct unit. Not available with DMX. Not available on individual units with NLTAIR2.
- Must select 120 or 277 volt. Remote mounted. Not available with sensor and BGTD in same unit. Not available with DMX.
- Comes with white CAT5 cord in addition to the standard power cord. Will require remote mounted nIO on 2' unit. One NLIGHT device per zone or sensor, for multiple zones consult factory.
- Must select MIN1 or DARK Dim Level. Not available with WW option or 2' & 3' units. Not available with WL. If ordered with E10WLCP, only available in 7' & 8' units. One NLTAIR2 device per zone or sensor, for multiple zones consult factory.
- Must select DARK Dim Level.
- Not available with 347V.
- Must select MIN1 Dim Level. Not available on 2', 3' or 5' units.
- 120V only.
- Requires ZT or NLIGHT Control Input.
- Requires ZT, NLIGHT or NLTAIR2 Control Input.



PHOTOMETRICS

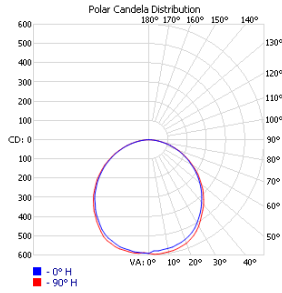

Test Report: ISF 37228P0
IES LM 79-08
S4LD 4FT 80CRI 30K 400LMF
Lumens: **1730**
Wattage: **15.37W**
Efficacy: **112.5**

Zonal Lumen Summary		
Zone	Lumens	% Luminaire
0-30	472.9	27%
0-40	773	44.70%
0-60	1359.4	78.60%
60-90	370	21.40%
70-100	159	9.20%
90-120	0.3	0%
0-90	1729.4	100%
90-180	0.6	0%
0-180	1730	100%

Angle	Candlepower Distribution								
	Plane								
	0	22.5	45	67.5	90	112.5	135	157.5	180
0	591	591	591	591	591	591	591	591	591
5	580	589	597	594	597	596	596	595	588
10	574	584	590	591	592	593	594	592	583
15	565	576	579	582	585	584	587	583	577
20	552	559	567	569	573	572	573	570	560
25	532	539	549	549	551	549	551	552	541
30	501	509	515	514	519	520	519	518	509
35	466	473	480	480	479	480	484	483	475
40	427	436	443	441	443	441	443	443	434
45	388	394	400	401	401	400	405	402	396
50	346	353	355	356	356	355	358	360	351
55	302	310	310	310	313	309	316	314	305
60	254	263	262	261	261	261	262	266	259
65	208	214	213	212	213	213	214	217	210
70	162	165	165	166	167	165	164	165	161
75	116	118	116	117	117	116	116	116	115
80	69	70	71	72	72	72	71	70	69
85	30	32	32	33	33	32	30	29	27
90	1	2	0	0	0	1	0	1	1

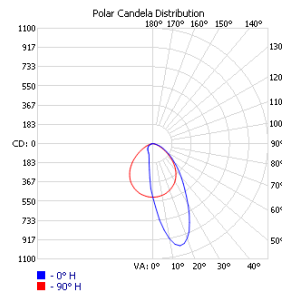

Test Report: ISF 37775P0
IES LM 79-08
S4LD 4FT 80CRI 30K 400LMF WW
Lumens: **1138**
Wattage: **14.51W**
Efficacy: **78.4**

Zonal Lumen Summary		
Zone	Lumens	% Luminaire
0-30	424.2	37.30%
0-40	657.7	57.80%
0-60	1003.1	88%
60-90	134.9	11.90%
0-90	1138	100.00%

Angle	Candlepower Distribution								
	Plane								
	0	22.5	45	67.5	90	112.5	135	157.5	180
0	509	509	509	509	509	509	509	509	509
5	730	708	659	590	509	433	371	337	326
10	922	896	813	676	501	351	256	214	202
15	1008	989	916	743	489	283	184	147	138
20	961	970	949	783	471	232	142	115	109
25	828	862	914	797	448	192	115	99	96
30	673	713	823	779	421	159	99	90	88
35	533	569	698	727	383	134	89	83	81
40	426	453	568	639	341	114	82	76	75
45	337	362	457	529	291	98	75	69	68
50	261	282	356	415	237	85	66	62	62
55	201	214	274	308	182	73	57	54	54
60	151	159	202	219	133	60	47	45	45
65	109	115	142	148	91	46	38	36	35
70	75	78	94	95	61	34	28	26	26
75	46	48	57	56	36	22	18	18	18
80	24	26	30	28	18	12	12	11	11
85	8	9	10	10	8	6	6	6	5
90	1	2	1	2	2	2	2	2	2

EXPECTED LIFE: L83 @ 60,000
CALCULATED LIFE: L70 @ 110,000

Shielding



Co-Extruded WG



Co-Extruded WW



Edge View Lens



External Louver



Regressed Louver

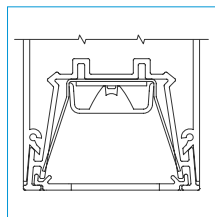

Co-Extruded WG (Standard)

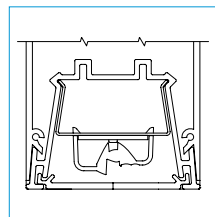

Co-Extruded WW (Standard)

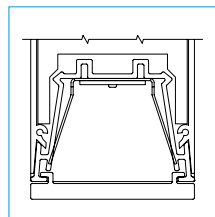

Edge View Lens (Optional)

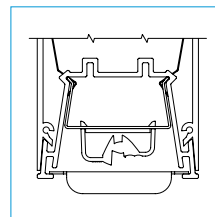

External Louver WW (Painted to Match Housing)

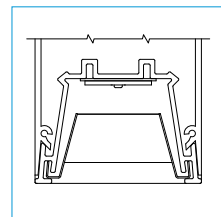

Regressed Louver (Natural Aluminum or Painted to Match Housing)

LINEAR PLAN:

Mark Lighting offers the ability to provide a continuous run plan to suit your requirements by optionally offering three different methods of configuration.

LLP- Linear Longest Possible

In this configuration, the longest length available is optimized, resulting in the fewest segments and mounting locations. Caution, should be used where balanced appearance is a concern. Example: 20 FT run would have 2, 8 FT segment and 1, 4 FT segment at the end of the run.



LCB- Linear Center Balanced:

This configuration incorporates the longest center segment(s) along with any additional lengths required to fill the run length, added to the run ends. Example: 16 FT run would have 2, 4 FT segments (one at each end) and 1, 8 FT segment in the center.



Individual Fixture Configurations

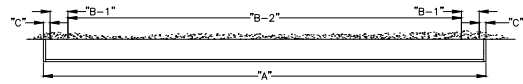

INDIVIDUAL UNITS (MOUNTING)				
LENGTH	"A" O.A.L.	"B-1" O.C.	"B-2" O.C.	"C" FROM END
2FT	2'- 5/8"	2"	1'-7"	13/16"
3FT	3'- 5/8"	2"	2'-7"	13/16"
4FT	4'- 5/8"	2"	3'-7"	13/16"
5FT	5'- 5/8"	2"	4'-7"	13/16"
6FT	6'- 5/8"	2"	5'-7"	13/16"
7FT	7'- 5/8"	2"	6'-7"	13/16"
8FT	8'- 5/8"	2"	7'-7"	13/16"

Run Configurations

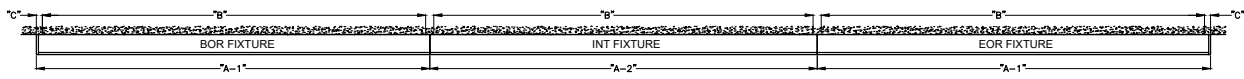

RUN LAYOUT (MOUNTING)				
LENGTH	"A-1" O.A.L.	"A-2" O.A.L.	"B" O.C.	"C" FROM END
4FT	4'-0 5/16"	4'-0"	4'-0"	13/16"
5FT	5'-0 5/16"	5'-0"	5'-0"	13/16"
6FT	6'-0 5/16"	6'-0"	6'-0"	13/16"
7FT	7'-0 5/16"	7'-0"	7'-0"	13/16"
8FT	8'-0 5/16"	8'-0"	8'-0"	13/16"

TOTAL RUN LENGTH

This system is not modular. Runs longer than 8FT will be automatically configured with Starter, Middle and Ender sections, based on how you specify the TOTAL RUN LENGTH and MAXIMUM SECTION LENGTH parameters in the ordering information. Always order the total run length, not the individual sections

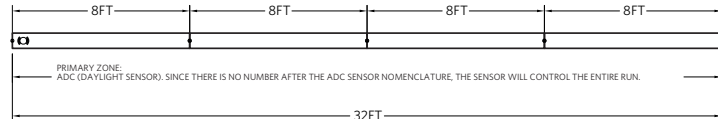

Example: This run must be ordered as 1pc "S4LS LLP 32FT MSL8..."



Example: If you order as 4pcs "S4LS LLP 8FT MSL8... you will receive these INDIVIDUAL sections that cannot be joined together

MAXIMUM SECTION LENGTH

The run will be broken out using as many sections at the chosen MSL length as possible. Shorter sections will then complete the desired run length.

- Examples:
 S4LS LLP 21FT MSL5... = 5FT / 4FT / 4FT / 4FT / 4FT
 S4LS LLP 21FT MSL6... = 6FT / 6FT / 5FT / 4FT
 S4LS LLP 21FT MSL7... = 7FT / 7FT / 7FT
 S4LS LLP 21FT MSL8... = 8FT / 8FT / 5FT

Run Patterns, Corners and Junction

Slot 4 LED patterns be configured in 1' increments with illuminated 90° inside and outside corners, T junctions, and X junctions with standard 2' corner and junction lengths. For custom angles, corner or junction lengths, consult factory. See separate pattern spec sheet for details.

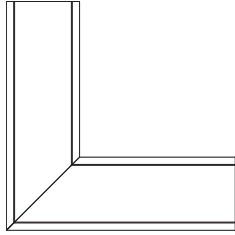

90° Corner

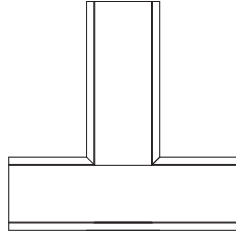

T Junction

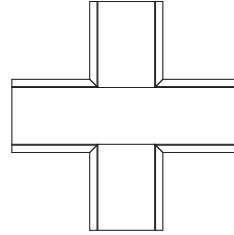

X Junction

Downlights

Optional downlights powered by Xicato Spot Modules are available with 4', 5', 6', and 8' length luminaires, maximum (2) Xicato downlights per length. Each downlight module is 10W with 700 lumens delivered, 28 degree beam spread.. Downlights are supplied with a dedicated feed point and will be controlled separately.



Standard Downlight Location

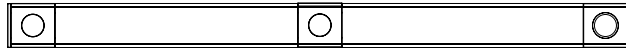

Other Downlight Configuration (consult factory)

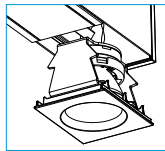

Downlight Module

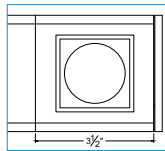

Square Downlight Plate (SQ)

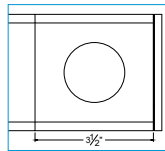

Round Downlight Plate (RD)

Mounting

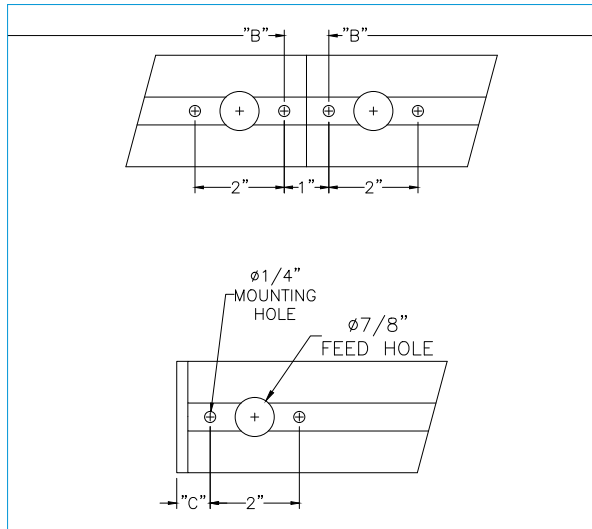

Our surface product mounts to hard/sheetrock ceilings only. Consult manufacturing for use with a grid ceiling.

Joiners

AEL Precision Row-Mount 3-step fixture-to-fixture connection method

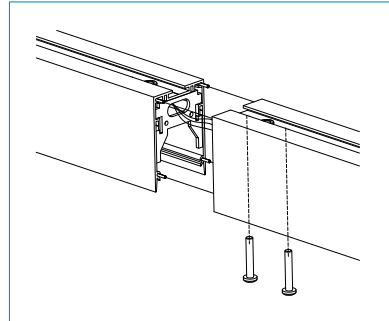

Step 1: Align

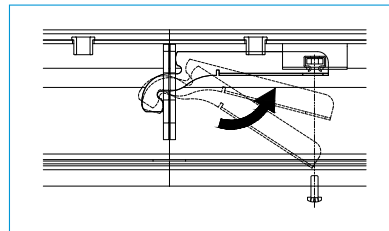

Step 2: Engage

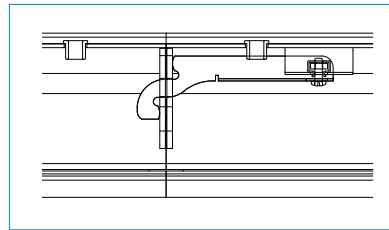

Step 3: Lock

Continuous Runs

Slot 4 LED continuous rows can be configured in 1' increments and featuring the AEL precision joiner to create a hairline seam between luminaires, providing a monolithic visual aesthetic. For custom run lengths less than a 1' increment, consult factory.

INTEGRATED SENSOR LAYOUT

For runs longer than 8FT:
ALWAYS order the run by the **TOTAL RUN LENGTH**. Ordering the sections individually will not provide the correct joining hardware to allow connection in the field.

CORRECT:

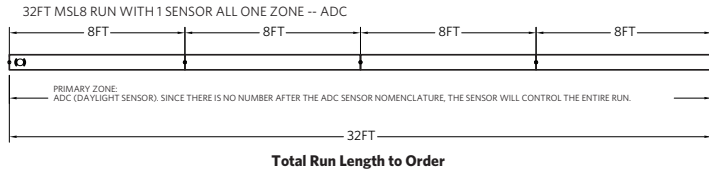
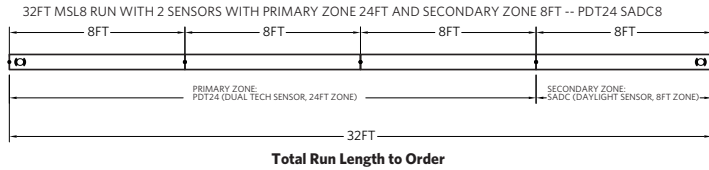

INCORRECT:

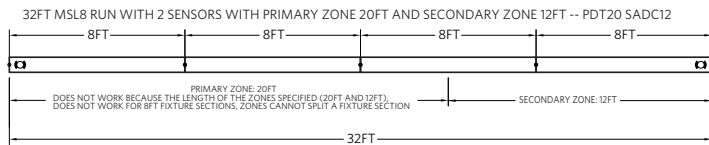
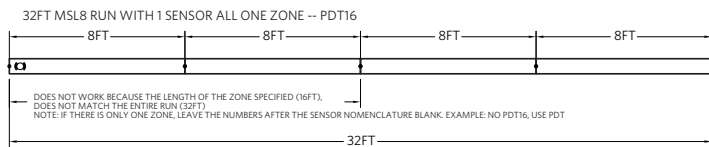

Notes:

- Only one sensor per zone
- At the most, the entire run can only have 2 sensors (thus 2 sensors zones at the most)
- Sensor zone can not split fixture sections
- No overlapping zones

OCCUPANCY DETECTION COVERAGE

At the 7.5 ft (2.9 m) hanging height of a typical pendant mount fixture the sensor provides 10 ft (3.05 m) radial detection of small motion. At a 9 ft (2.74 m) hanging height the radius is 12 ft (3.66 m) for small motion.

Adequate for walking motion detection from mounting heights between 7.5 ft (2.29 m) and 20 ft (6.10 m).

Initial detection will occur earlier when walking across sensor's field of view than when walking directly at sensor.

Initial detection of walking motion into long coverage segment will occur at distances of 2x the mounting height up to 15 ft (4.57 m) and 1.75x up to 20 ft (6.10 m). Lens assembly rotates 15° to enable adjustment in order to line up long segments.

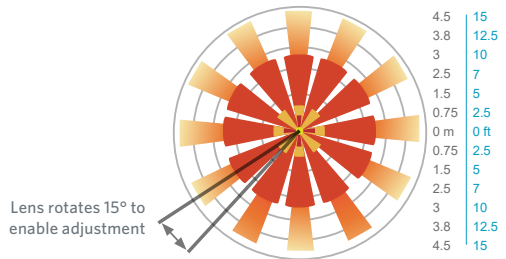

Integrated Controls
Optional nLight® integrated controls make Slot LED luminaires addressable- allowing them to digitally communicate with other nLight enabled controls such as dimmers, switches, occupancy sensors and photocontrols. Simply connect all the nLight enabled control devices using standard CAT5 Cabling.

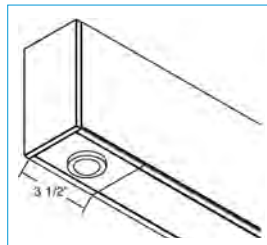

Occupancy Sensor (MSD9N) and/or Photocell (DSCC)

Intelligent Luminaire Technology Guide

		Choose nomenclature from these columns				
Driver Configurations	Minimum Dimming Level	Control Input	Driver	Dimming Range	Notes	
	NODIM	+	(blank)	= 0 10V Generic Driver	-	Includes no 0 10V leads from the driver.
	MIN10	+	ZT	= 0 10V Generic Driver	100 to 10%	Linear dimming
	MIN1	+	ZT	= 0 10V eldoLED ECOdrive	100 to 1%	Formerly (EZ1) nomenclature. Linear dimming
	MIN1	+	NLIGHT	= 0 10V eldoLED ECOdrive	100 to 1%	Logarithmic dimming
	MIN1	+	ECOD2	= Lutron forward phase control	100 to 1%	LUTRON Hi-lume 1% 2-wire (model LTEA4U1U)
	MIN1	+	ECOD5	= Lutron Ecosystem	100 to 5%	LUTRON 5 Seires EcoSystem LED Driver (model LDE5)
	MIN1	+	ECOD	= Lutron Ecosystem	100 to 1%	LUTRON Hi-lume 1% EcoSystem LED Driver with Soft-on, Fade-to-Black (model LDE1)
	DARK		ZT	= 0 10V eldoLED SOLOdrive	100 to 0.1%	Formerly (EZB) nomenclature. Linear dimming
	DARK		NLIGHT	= 0 10V eldoLED SOLOdrive	100 to 0.1%	Logarithmic dimming
	DARK		DALI	= DALI compatible eldoLED SOLOdrive	100 to 0.1%	"Compatible with DALI. Formerly (EDB & EDAB) nomenclature." Logarithmic dimming
	DARK		DMX	= DMX compatible eldoLED POWERdrive	100 to 0.1%	"Compatible with DMX / Remote Device Management. Formerly (EXB & EDXB) nomenclature." Linear dimming

		Choose nomenclature from these columns				
Control / Sensor Configurations	Control Input	Sensor	Sensor	Notes		
	ZT	+	API	= MSD 7 ADCX	Individual fixture control only. PIR integral occupancy sensor with automatic dimming control photocell. (Old nomenclature: ZT + PIR + ADC)	
	ZT	+	APD	= MSD PDT 7 ADCX	Individual fixture control only. PDT integral occupancy sensor with automatic dimming control photocell. (Old nomenclature: ZT + PDT + ADC)	
	NLIGHT	+	(blank)	= nIO EZ PH	nLight enabled only. No onboard sensor.	
	NLIGHT		EMG	= nIO EZ PH ER	Emergency nLight enabled only. No onboard sensor.	
	NLIGHT	+	API	= nIO EZ PH + nES 7 ADCX	nLight nES 7 ADCX PIR integral occupancy sensor with automatic dimming photocell. (Old nomenclature: NLIGHT + PIR + ADC)	
	NLIGHT	+	PDT	= nIO EZ PH + nES PDT 7	nLight nES PDT 7 dual technology integral occupancy sensor. (Old nomenclature: NLIGHT + PDT)	
	NLIGHT	+	APD	= nIO EZ PH + nES PDT 7 ADCX	nLight nES PDT 7 dual technology integral occupancy sensor with automatic dimming photocell. (Old nomenclature: NLIGHT + PDT + ADC)	
	NLTAIR2		(blank)	= RIO EZDL 90D G2	https://www.acuitybrands.com/products/detail/778845/nLight/RIO/Fixture-embedded-nLight-AIR-network-interface	
	NLTAIR2		API	= RES7 G2	https://www.acuitybrands.com/products/detail/593899/nLight/RES7_Sensor/nLight-AIR_Fixture-Integrated-Wireless-Sensor	
	NLTAIR2		APD	= RES7 PDT G2	https://www.acuitybrands.com/products/detail/593899/nLight/RES7_Sensor/nLight-AIR_Fixture-Integrated-Wireless-Sensor	

Remote BGTD Mounting Option

Recessed in sheetrock ceiling; rod mounted to structure. Consult factory for other ceiling types or canopy options.

6 foot flexible conduit included, BGTD option should be mounted within 6 feet of junction box above fixture.

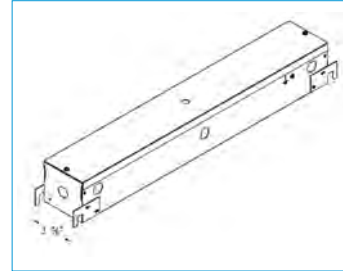
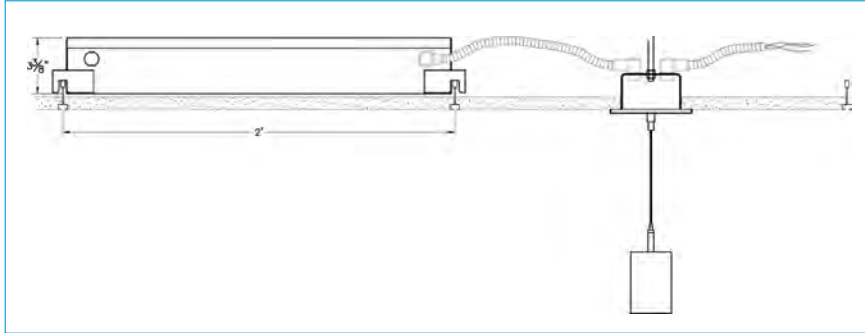

Accessible Ceiling

Emergency Battery Packs

The PS1055LCP battery is integral to the fixture and comes standard with a remote test switch and self-diagnostics.

MARK
ARCHITECTURAL
LIGHTING™

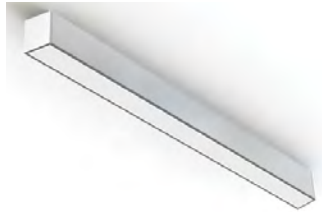

Slot 4 LED
Surface Mount

The Slot LED family of luminaires offers an unparalleled package of performance and features for your next lighting project. Precision lumen DIRECTIR optics deliver optimized light where needed for ceilings and walls. With other key features such as simplified installation, seamless controls integration and superior LED color constancy, the Slot LED family from Mark Lighting offers exceptional quality and design flexibility.

Type:

Project:

Catalog Number:

DO NOT TYPE HERE. Autopopulated field.

Specification Features

Housing

Nominal 3.5" x 3.75" extruded aluminum housing

Finish

White, Black or Silver powdercoat

Reflector

Formed steel with high reflectance white.

Distribution/Shielding

Extruded 90% transmissive acrylic lens with a textured surface providing diffuse illumination and a uniform appearance for direct lambertian distribution (No Optics). Wall Wash (WW) and Wall Graze (WG) distribution options incorporate co-extruded lenses. Shielding is available as an external blade louver for WW or WG options, or an internal blade louver in lieu of lambertian distribution diffuser.

LED Components

Linear: Nichia®- 757 series LED chips (>80 CRI)

Electrical

Long-life LEDs, coupled with high-efficiency drivers, provide superior quantity and quality of illumination for extended service life. 80% LED lumen maintenance at 60,000 hours (L80/60,000).

Color Consistency

The Acuity Brands circuit boards for the linear LED components use a precise binning algorithm which creates a consistent color temperature from board to board. The color a variation of no greater than a 2.5 Step MacAdam (2.5SDCM) along the black body locus from board to board.

Driver

Factory tuned constant current electronic dimming driver is standard. Flicker free dimming available down to <1%. LED drivers perform within the recommended operating areas for flicker as a function of frequency and modulation (%) IEEE Standard 1789-2015 (IEEE Recommended Practices for Modulating Current in High-Brightness LEDs for Mitigating Health Risks to Viewers), in typical operating conditions at representative dimming levels. Electrical specifications at maximum driver load: PF > 0.9 and THD <20%. Meets FCC Title 47 Class A or Class B. Other available drivers include Lutron, DMX and DALI protocol drivers.

Certification

CSA tested to UL 1598 standards, assembled in the USA. Damp location listed.

Listings

DesignLights Consortium® (DLC) Premium qualified product. Not all versions of this product may be DLC Premium qualified. Please check the DLC Qualified Products List at www.designlights.org/OPL to confirm which versions are qualified.

Warranty

5-year limited warranty. Complete warranty terms located at: www.acuitybrands.com/support/warranty/terms-and-conditions

Note: Actual performance may differ as a result of end-user environment and application.

All values are design or typical values, measured under laboratory conditions at 25 °C.

Specifications subject to change without notice.

Fixture Performance

4FT INDIVIDUAL (35K)	DIRECT			
	400LMF	600LMF	800LMF	1000LMF
Delivered Lumens	1800	2707	3571	4103
Input Watts	15.4	23.4	32	37.3
Lumen/Watt	117	115	112	110

* Consult factory for customized lumen output and wattage between 350LMF and 1050LMF.

Technical Drawing

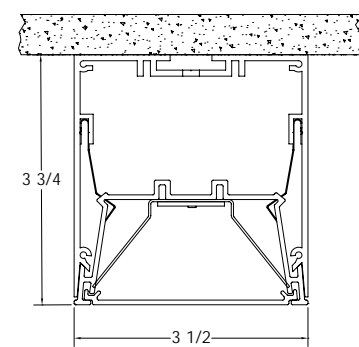

Direct Surface



eldoLED
your product our drive

Declare.



Buy American



Buy American:

Product with the BAA option is assembled in the USA and meets the Buy America(n) government procurement requirements under FAR, DFARS and DOT. Please refer to www.acuitybrands.com/buy-american for additional information.

A+ Capable Luminaire

This item is an A+ capable luminaire, which has been designed and tested to provide consistent color appearance and out-of-the-box control compatibility with simple commissioning.

- All configurations of this luminaire meet the Acuity Brands' specification for chromatic consistency
- This luminaire is part of an A+ Certified solution for nLight® control networks when ordered with drivers marked by a shaded background*
- This luminaire is part of an A+ Certified solution for nLight control networks, providing advanced control functionality at the luminaire level, when selection includes driver and control options marked by a shaded background*

To learn more about A+, visit www.acuitybrands.com/aplus.

*See ordering tree for details



Catalog
Information:

S4LS-LLP-8FT-MSL8-90CRI-35K-1000LMF-MIN1-MVOLT-
1E10WLCP-[FINISH]-ZT

Date:01/27/2023
Fixture Type:

B4-EM

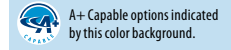

Ordering

Example: S4LS 32FT MSL8 90CRI 40K 1000LMF DARK EGLD 120 WHT ZT

Series	Plan	Total Run Length	Max Section Length	Direct Light Source Color Rendering	Direct LED Color Temp	Direct LED Light Output	Direct Distribution (Optics)
S4LS Slot 4 Surface - Direct	LCB Linear center balanced LLP Linear longest possible	8FT _FT Specify continuous run length (in whole feet, 2' minimum). Unit length may affect available options. 2' & 3' only available as individual units. For runs longer than 8FT: ALWAYS order the run by the TOTAL RUN LENGTH. Ordering the sections individually will not provide the correct joining hardware to allow connection in the field.	MSL4 4' MSL5 5' MSL6 6' MSL7 7' MSL8 8'	80CRI 80 CRI 90CRI 90 CRI	27K 2700K 30K 3000K 35K 3500K 40K 4000K 50K 5000K	400LMF 400 lumens per FT 600LMF 600 lumens per FT 800LMF 800 lumens per FT 1000LMF 1000 lumens per FT _LMF¹ # lumens per FT	(blank) Standard lambertian distribution WW² Wallwash distributions WG Wall graze distribution WW and WG not available with Downlights, EGLD, LVRR or LVRRRA.

Downlight	Downlight Shape	Downlight Color Rendering	Downlight Color Temp	Minimum Dimming Level	Optional Shielding	Voltage
(blank) No Downlight modules in fixture 2DL LED downlights (2 per unit) _DL LED downlights per run (3DL, 4DL, etc.)	(blank) No downlight modules in fixture RDD Round SQD Square	(blank) No downlight modules in fixture S80CRI 80 CRI	(blank) No downlight modules in fixture S27K 2700K S30K 3000K S35K 3500K S40K 4000K	NODIM³ Non-dimming MIN1 Constant current, dimming to 1% DARK Constant current, dimming to 0.1%	(blank) No louver LVRR⁴ Dropped louver LVRR⁴ Regressed louver painted to match fixture finish LVRRRA⁶ Regressed louver, aluminum finish EGLD⁴,⁵ Edge View direct lens Not available with Downlights. Not available with NLTAIR2.	MVOLT Multi-volt, 120-277V 120 120V 277 277V 347⁷ 347V

Finish	Emergency Options	Control Input	Sensor	Secondary Sensor
WHT White (gloss) BLK Black (gloss) SLV Silver (gloss) WHHT White (textured) BLKT Black (textured) SLVT Silver (textured) RALTB RAL paint finishes	E10WLCP⁸ 4' emergency section w/ battery pack, 1250 lumens _E10WLCP⁸ 4' emergency section w/ battery pack, 1250 lumens _EC⁹ # of emergency circuits BGTD³,¹⁰ Generator transfer device Not available with 347V.	(blank) Non-dimming, line voltage ZT 0-10V control NLIGHT¹¹ nLight enabled NLTAIR2¹² nLight AIR (wireless) enabled DALI¹³,¹⁴ DALI compatible DMX¹³,¹⁴ DMX compatible ECOD¹⁴,¹⁵ Lutron Hi-Lume digital driver ECOD2¹⁴,¹⁵,¹⁶ Lutron Hi-Lume 2-wire (1% dimming) ECOD5¹⁴,¹⁵ Lutron 5-series digital driver (5% dimming)	(blank) Select if single zone/no zone without sensor NS Select if multi-zone fixture with no sensor in main zone PDT¹⁷ Occupancy sensor - dual technology (passive infrared & microphonic) ADC¹⁷ Photocell-daylight dimming sensor API¹⁸ PIR occupancy sensor & photocell APD¹⁸ PDT occupancy sensor & photocell Not available with Downlights. Not available with 347V & nLight. (Use ZT or NLTAIR2 Control Inputs where applicable.) Not available on 2' or 3' units.	(blank) No additional zones/sensors SNS Select if multi-zone fixture with no sensor in secondary zone SPDT¹⁷ Occupancy sensor - dual technology (passive infrared & microphonic) SADC¹⁷ Photocell-daylight dimming sensor SAPI¹⁸ PIR occupancy sensor & photocell SAPD¹⁸ PDT occupancy sensor & photocell Not available with Downlights. Not available with 347V & nLight. (Use ZT or NLTAIR2 Control Inputs where applicable.) Not available on 2' or 3' units.

Tertiary Sensor	Options
(blank) No additional zones/sensors TNS Select if multi-zone fixture with no sensor in tertiary zone	BAA Buy America(n) Compliant GLR¹⁴ Fast-blow fuse GMF¹⁴ Slow-blow fuse WL¹⁴ Wet Location

Notes:

- Limited to 350LMF to 1050LMF in 50LMF increments. Not available with ECOD, ECOD2, ECOD5 or DMX control input.
- Not available with NLTAIR2.
- Not available with Control Input.
- Not available with Sensor Options.
- Not available with Emergency Options.
- Not available with sensors on 2', 3' & 4' units.
- Not available with ZT & sensors, with NLTAIR2, with emergency options, with NLIGHT in 5' units, with NLIGHT & downlights.
- Not available with 2' or 3' units. Not available with DMX control option. One battery pack per unit. Only available on 8' unit with ECOD, ECOD2, ECOD5. Not available on 5' unit with NLTAIR. If with ZT & API, APD, or NLTAIR2 only available in 7' & 8' units.
- Powers entire direct unit. Not available with DMX. Not available on individual units with NLTAIR2.
- Must select 120 or 277 volt. Remote mounted. Not available with sensor and BGTD in same unit. Not available with DMX.
- Comes with white CAT5 cord in addition to the standard power cord. Will require remote mounted nIO on 2' unit. One NLIGHT device per zone or sensor, for multiple zones consult factory.
- Must select MIN1 or DARK Dim Level. Not available with WW option or 2' & 3' units. Not available with WL. If ordered with E10WLCP, only available in 7' & 8' units. One NLTAIR2 device per zone or sensor, for multiple zones consult factory.
- Must select DARK Dim Level.
- Not available with 347V.
- Must select MIN1 Dim Level. Not available on 2', 3' or 5' units.
- 120V only.
- Requires ZT or NLIGHT Control Input.
- Requires ZT, NLIGHT or NLTAIR2 Control Input.



PHOTOMETRICS

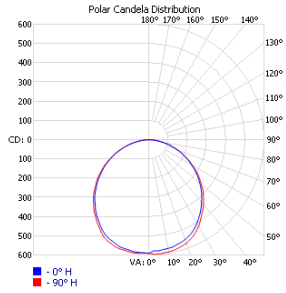

Test Report: ISF 37228P0
IES LM 79-08
S4LD 4FT 80CRI 30K 400LMF
Lumens: **1730**
Wattage: **15.37W**
Efficacy: **112.5**

Zonal Lumen Summary		
Zone	Lumens	% Luminaire
0-30	472.9	27%
0-40	773	44.70%
0-60	1359.4	78.60%
60-90	370	21.40%
70-100	159	9.20%
90-120	0.3	0%
0-90	1729.4	100%
90-180	0.6	0%
0-180	1730	100%

Angle	Candlepower Distribution								
	Plane								
	0	22.5	45	67.5	90	112.5	135	157.5	180
0	591	591	591	591	591	591	591	591	591
5	580	589	597	594	597	596	596	595	588
10	574	584	590	591	592	593	594	592	583
15	565	576	579	582	585	584	587	583	577
20	552	559	567	569	573	572	573	570	560
25	532	539	549	549	551	549	551	552	541
30	501	509	515	514	519	520	519	518	509
35	466	473	480	480	479	480	484	483	475
40	427	436	443	441	443	441	443	443	434
45	388	394	400	401	401	400	405	402	396
50	346	353	355	356	356	355	358	360	351
55	302	310	310	310	313	309	316	314	305
60	254	263	262	261	261	261	262	266	259
65	208	214	213	212	213	213	214	217	210
70	162	165	165	166	167	165	164	165	161
75	116	118	116	117	117	116	116	116	115
80	69	70	71	72	72	72	71	70	69
85	30	32	32	33	33	32	30	29	27
90	1	2	0	0	0	1	0	1	1

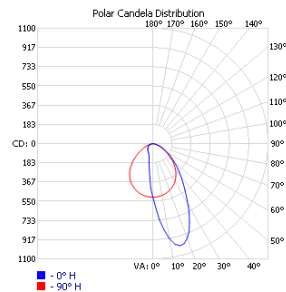

Test Report: ISF 37775P0
IES LM 79-08
S4LD 4FT 80CRI 30K 400LMF WW
Lumens: **1138**
Wattage: **14.51W**
Efficacy: **78.4**

Zonal Lumen Summary		
Zone	Lumens	% Luminaire
0-30	424.2	37.30%
0-40	657.7	57.80%
0-60	1003.1	88%
60-90	134.9	11.90%
0-90	1138	100.00%

Angle	Candlepower Distribution								
	Plane								
	0	22.5	45	67.5	90	112.5	135	157.5	180
0	509	509	509	509	509	509	509	509	509
5	730	708	659	590	509	433	371	337	326
10	922	896	813	676	501	351	256	214	202
15	1008	989	916	743	489	283	184	147	138
20	961	970	949	783	471	232	142	115	109
25	828	862	914	797	448	192	115	99	96
30	673	713	823	779	421	159	99	90	88
35	533	569	698	727	383	134	89	83	81
40	426	453	568	639	341	114	82	76	75
45	337	362	457	529	291	98	75	69	68
50	261	282	356	415	237	85	66	62	62
55	201	214	274	308	182	73	57	54	54
60	151	159	202	219	133	60	47	45	45
65	109	115	142	148	91	46	38	36	35
70	75	78	94	95	61	34	28	26	26
75	46	48	57	56	36	22	18	18	18
80	24	26	30	28	18	12	12	11	11
85	8	9	10	10	8	6	6	6	5
90	1	2	1	2	2	2	2	2	2

EXPECTED LIFE: L83 @ 60,000
CALCULATED LIFE: L70 @ 110,000

Shielding



Co-Extruded WG



Co-Extruded WW



Edge View Lens



External Louver



Regressed Louver

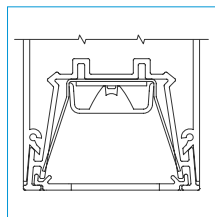

Co-Extruded WG (Standard)

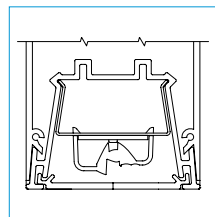

Co-Extruded WW (Standard)

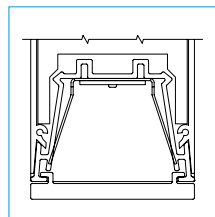

Edge View Lens (Optional)

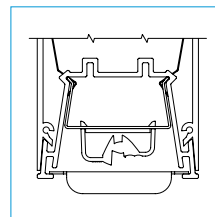

External Louver WW (Painted to Match Housing)

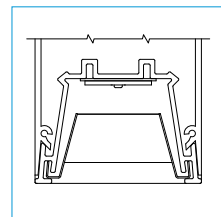

Regressed Louver (Natural Aluminum or Painted to Match Housing)

LINEAR PLAN:

Mark Lighting offers the ability to provide a continuous run plan to suit your requirements by optionally offering three different methods of configuration.

LLP- Linear Longest Possible

In this configuration, the longest length available is optimized, resulting in the fewest segments and mounting locations. Caution, should be used where balanced appearance is a concern. Example: 20 FT run would have 2, 8 FT segment and 1, 4 FT segment at the end of the run.



LCB- Linear Center Balanced:

This configuration incorporates the longest center segment(s) along with any additional lengths required to fill the run length, added to the run ends. Example: 16 FT run would have 2, 4 FT segments (one at each end) and 1, 8 FT segment in the center.

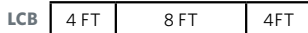

Individual Fixture Configurations

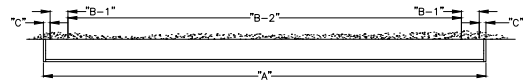

INDIVIDUAL UNITS (MOUNTING)				
LENGTH	"A" O.A.L.	"B-1" O.C.	"B-2" O.C.	"C" FROM END
2FT	2'- 5/8"	2"	1'-7"	13/16"
3FT	3'- 5/8"	2"	2'-7"	13/16"
4FT	4'- 5/8"	2"	3'-7"	13/16"
5FT	5'- 5/8"	2"	4'-7"	13/16"
6FT	6'- 5/8"	2"	5'-7"	13/16"
7FT	7'- 5/8"	2"	6'-7"	13/16"
8FT	8'- 5/8"	2"	7'-7"	13/16"

Run Configurations

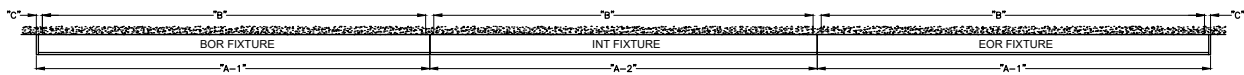

RUN LAYOUT (MOUNTING)				
LENGTH	"A-1" O.A.L.	"A-2" O.A.L.	"B" O.C.	"C" FROM END
4FT	4'-0 5/16"	4'-0"	4'-0"	13/16"
5FT	5'-0 5/16"	5'-0"	5'-0"	13/16"
6FT	6'-0 5/16"	6'-0"	6'-0"	13/16"
7FT	7'-0 5/16"	7'-0"	7'-0"	13/16"
8FT	8'-0 5/16"	8'-0"	8'-0"	13/16"

TOTAL RUN LENGTH

This system is not modular. Runs longer than 8FT will be automatically configured with Starter, Middle and Ender sections, based on how you specify the TOTAL RUN LENGTH and MAXIMUM SECTION LENGTH parameters in the ordering information. Always order the total run length, not the individual sections

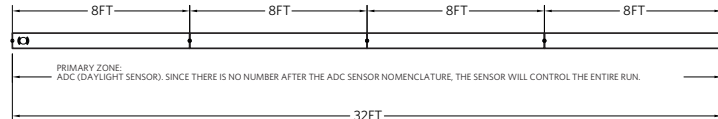

Example: This run must be ordered as 1pc "S4LS LLP 32FT MSL8..."



Example: If you order as 4pcs "S4LS LLP 8FT MSL8... you will receive these INDIVIDUAL sections that cannot be joined together

MAXIMUM SECTION LENGTH

The run will be broken out using as many sections at the chosen MSL length as possible. Shorter sections will then complete the desired run length.

- Examples:
 S4LS LLP 21FT MSL5... = 5FT / 4FT / 4FT / 4FT / 4FT
 S4LS LLP 21FT MSL6... = 6FT / 6FT / 5FT / 4FT
 S4LS LLP 21FT MSL7... = 7FT / 7FT / 7FT
 S4LS LLP 21FT MSL8... = 8FT / 8FT / 5FT

Run Patterns, Corners and Junction

Slot 4 LED patterns be configured in 1' increments with illuminated 90° inside and outside corners, T junctions, and X junctions with standard 2' corner and junction lengths. For custom angles, corner or junction lengths, consult factory. See separate pattern spec sheet for details.

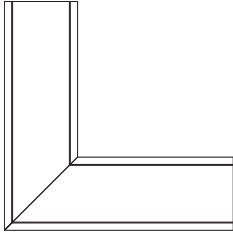

90° Corner

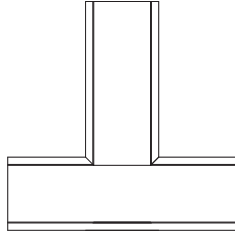

T Junction

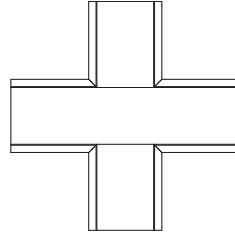

X Junction

Downlights

Optional downlights powered by Xicato Spot Modules are available with 4', 5', 6', and 8' length luminaires, maximum (2) Xicato downlights per length. Each downlight module is 10W with 700 lumens delivered, 28 degree beam spread.. Downlights are supplied with a dedicated feed point and will be controlled separately.



Standard Downlight Location

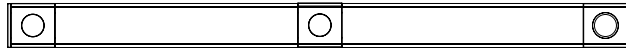

Other Downlight Configuration (consult factory)

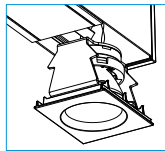

Downlight Module

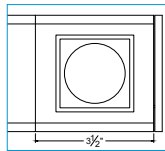

Square Downlight Plate (SQ)

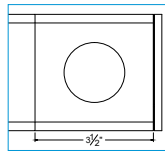

Round Downlight Plate (RD)

Mounting

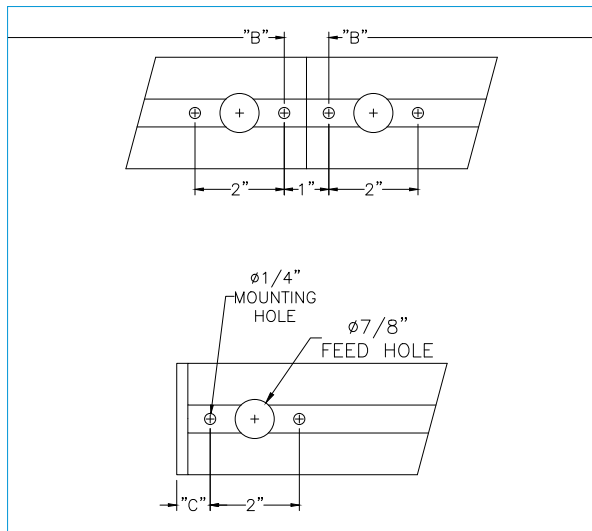

Our surface product mounts to hard/sheetrock ceilings only. Consult manufacturing for use with a grid ceiling.

Joiners

AEL Precision Row-Mount 3-step fixture-to-fixture connection method

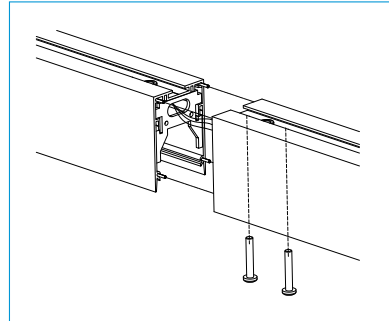

Step 1: Align

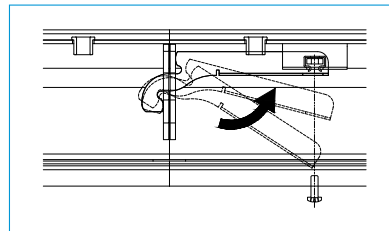

Step 2: Engage

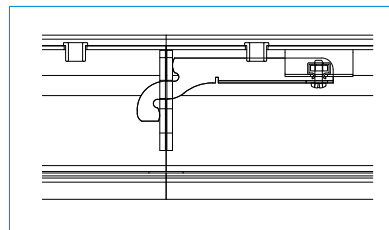

Step 3: Lock

Continuous Runs

Slot 4 LED continuous rows can be configured in 1' increments and featuring the AEL precision joiner to create a hairline seam between luminaires, providing a monolithic visual aesthetic. For custom run lengths less than a 1' increment, consult factory.

INTEGRATED SENSOR LAYOUT

For runs longer than 8FT:
ALWAYS order the run by the **TOTAL RUN LENGTH**. Ordering the sections individually will not provide the correct joining hardware to allow connection in the field.

CORRECT:

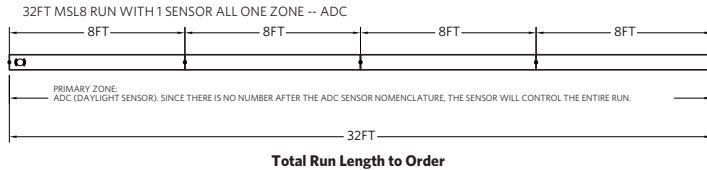
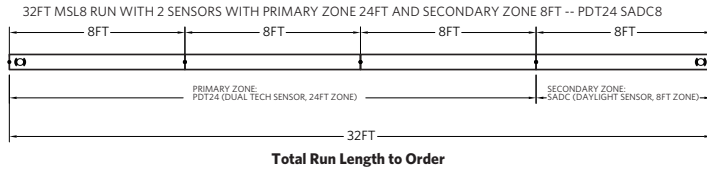

INCORRECT:

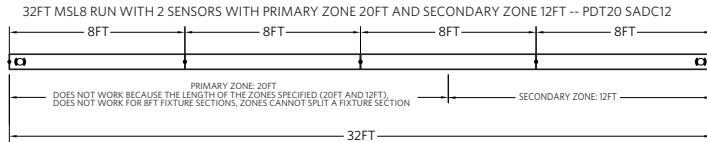
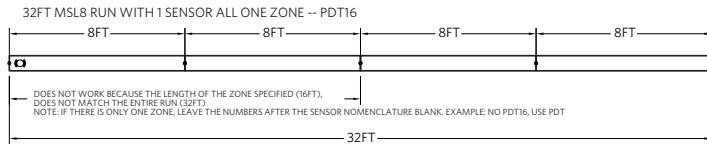

Notes:

- Only one sensor per zone
- At the most, the entire run can only have 2 sensors (thus 2 sensors zones at the most)
- Sensor zone can not split fixture sections
- No overlapping zones

OCCUPANCY DETECTION COVERAGE

At the 7.5 ft (2.9 m) hanging height of a typical pendant mount fixture the sensor provides 10 ft (3.05 m) radial detection of small motion. At a 9 ft (2.74 m) hanging height the radius is 12 ft (3.66 m) for small motion.

Adequate for walking motion detection from mounting heights between 7.5 ft (2.29 m) and 20 ft (6.10 m).

Initial detection will occur earlier when walking across sensor's field of view than when walking directly at sensor.

Initial detection of walking motion into long coverage segment will occur at distances of 2x the mounting height up to 15 ft (4.57 m) and 1.75x up to 20 ft (6.10 m). Lens assembly rotates 15° to enable adjustment in order to line up long segments.

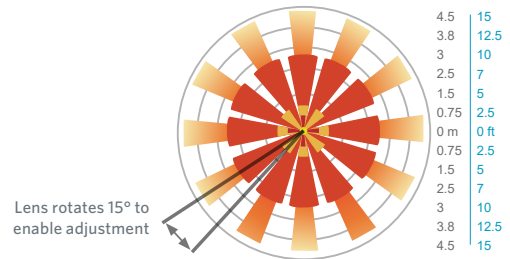

Integrated Controls
Optional nLight® integrated controls make Slot LED luminaires addressable- allowing them to digitally communicate with other nLight enabled controls such as dimmers, switches, occupancy sensors and photocontrols. Simply connect all the nLight enabled control devices using standard CAT5 Cabling.

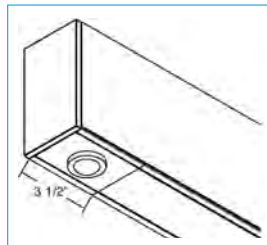

Occupancy Sensor (MSD9N) and/or Photocell (DSCC)

Intelligent Luminaire Technology Guide

		Choose nomenclature from these columns					
Driver Configurations	Minimum Dimming Level	Control Input	=	Driver	Dimming Range	Notes	
	NODIM	+	(blank)	=	0 10V Generic Driver	-	Includes no 0 10V leads from the driver.
	MIN10	+	ZT	=	0 10V Generic Driver	100 to 10%	Linear dimming
	MIN1	+	ZT	=	0 10V eldoLED ECOdrive	100 to 1%	Formerly (EZ1) nomenclature. Linear dimming
	MIN1	+	NLIGHT	=	0 10V eldoLED ECOdrive	100 to 1%	Logarithmic dimming
	MIN1	+	ECOD2	=	Lutron forward phase control	100 to 1%	LUTRON Hi-lume 1% 2-wire (model LTEA4U1U)
	MIN1	+	ECOD5	=	Lutron Ecosystem	100 to 5%	LUTRON 5 Seires EcoSystem LED Driver (model LDE5)
	MIN1	+	ECOD	=	Lutron Ecosystem	100 to 1%	LUTRON Hi-lume 1% EcoSystem LED Driver with Soft-on, Fade-to-Black (model LDE1)
	DARK		ZT		0 10V eldoLED SOLOdrive	100 to 0.1%	Formerly (EZB) nomenclature. Linear dimming
	DARK		NLIGHT		0 10V eldoLED SOLOdrive	100 to 0.1%	Logarithmic dimming
	DARK		DALI		DALI compatible eldoLED SOLOdrive	100 to 0.1%	"Compatible with DALI. Formerly (EDB & EDAB) nomenclature." Logarithmic dimming
	DARK		DMX		DMX compatible eldoLED POWERdrive	100 to 0.1%	"Compatible with DMX / Remote Device Management. Formerly (EXB & EDXB) nomenclature." Linear dimming

		Choose nomenclature from these columns				
Control / Sensor Configurations	Control Input	Sensor	=	Sensor	Notes	
	ZT	+	API	=	MSD 7 ADCX	Individual fixture control only. PIR integral occupancy sensor with automatic dimming control photocell. (Old nomenclature: ZT + PIR + ADC)
	ZT	+	APD	=	MSD PDT 7 ADCX	Individual fixture control only. PDT integral occupancy sensor with automatic dimming control photocell. (Old nomenclature: ZT + PDT + ADC)
	NLIGHT	+	(blank)	=	nIO EZ PH	nLight enabled only. No onboard sensor.
	NLIGHT		EMG	=	nIO EZ PH ER	Emergency nLight enabled only. No onboard sensor.
	NLIGHT	+	API	=	nIO EZ PH + nES 7 ADCX	nLight nES 7 ADCX PIR integral occupancy sensor with automatic dimming photocell. (Old nomenclature: NLIGHT + PIR + ADC)
	NLIGHT	+	PDT	=	nIO EZ PH + nES PDT 7	nLight nES PDT 7 dual technology integral occupancy sensor. (Old nomenclature: NLIGHT + PDT)
	NLIGHT	+	APD	=	nIO EZ PH + nES PDT 7 ADCX	nLight nES PDT 7 dual technology integral occupancy sensor with automatic dimming photocell. (Old nomenclature: NLIGHT + PDT + ADC)
	NLTAIR2		(blank)		RIO EZDL 90D G2	https://www.acuitybrands.com/products/detail/778845/nLight/RIO/Fixture-embedded-nLight-AIR-network-interface
	NLTAIR2		API		RES7 G2	https://www.acuitybrands.com/products/detail/593899/nLight/RES7_Sensor/nLight-AIR_Fixture-Integrated-Wireless-Sensor
	NLTAIR2		APD		RES7 PDT G2	https://www.acuitybrands.com/products/detail/593899/nLight/RES7_Sensor/nLight-AIR_Fixture-Integrated-Wireless-Sensor

Remote BGTD Mounting Option

Recessed in sheetrock ceiling; rod mounted to structure. Consult factory for other ceiling types or canopy options.

6 foot flexible conduit included, BGTD option should be mounted within 6 feet of junction box above fixture.

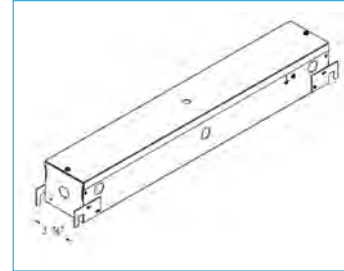
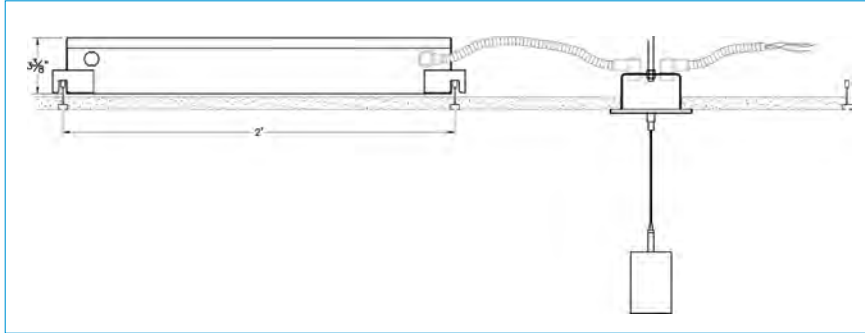

Accessible Ceiling

Emergency Battery Packs

The PS1055LCP battery is integral to the fixture and comes standard with a remote test switch and self-diagnostics.

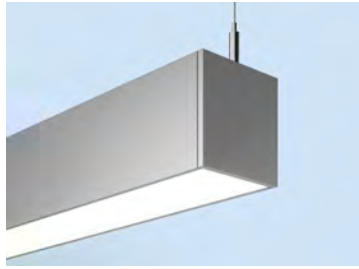

SLOT 4

PENDANT DIRECT

HIGHLIGHTS

- 300 to 1500 lumens per foot Direct
- Up to 126 Lumens per Watt
- 5 direct distributions: Lambertian, Batwing, Wall Wash, Wall Graze or Asymmetric
- Multiple lens treatment options include Continuous, Drop, in 1/2", 1" or 1 1/2" and Edge View
- Shielding provided by optional deep cell baffle
- Integrated control with optional nLight or nLight Air for system networking
- Driver options for Dim to Dark, 1% or 10% minimum dimming
- White, black or silver paint with satin finish
- Declare listed
- UGR data available on page 3

DIMENSIONS

See page 5 for additional details.

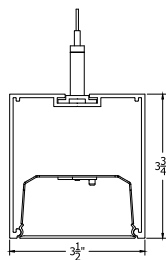

FIXTURE PERFORMANCE

Nominal Lumens/Foot	Direct							
	300LMF	400LMF	600LMF	800LMF	1000LMF	1200LMF	1400LMF	1500LMF
Delivered Lumens/Foot	292	394	575	791	973	1192	1352	1442
Input Watts/Foot	2.39	3.14	4.68	6.33	7.96	10.00	11.93	13.01
Lumens/Watt	122	126	123	125	122	119	113	111

Based on 4FT, 80CRI, 35K with standard Lambertian distribution.



DIRECT DISTRIBUTION

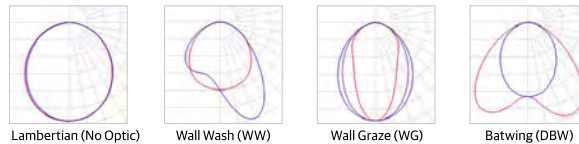

DIFFUSERS/SHIELDING

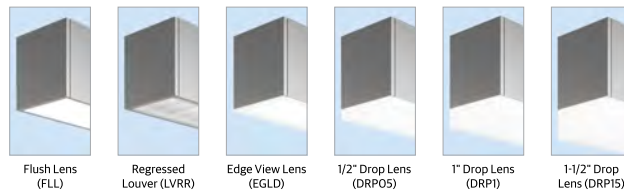

ORDERING

Example: S4PD LLP 32FT MSL8 90CRI 35K 800LMF MINI FLL SCT MVOLT WHTT ZT F1/36A RDCY WHTCY WCRD

--	--	--	--	--	--	--	--

Series	Linear Plan	Total Run Length	Max Section Length	Direct Light Source Color Rendering	Direct LED Color Temp	Direct LED Light Output	Direct Distribution (Optics)
S4PD SLOT 4 Pendant Direct (Formerly S4LD)	LLP Linear Longest Possible LCB Linear Center Balanced LSL Longest Same Length For more information on linear plans, see page 4.	_FT Specify Continuous Run Length (in 1" increments, 2" minimum) Unit length may affect available options. For runs longer than 8FT: ALWAYS order the sections individually will not provide the correct joining hardware to allow connection in the field.	MSL2 2FT Length MSL3 3FT Length MSL4 4FT Length MSL5 5FT Length MSL6 6FT Length MSL7 7FT Length MSL8 8FT Length	80CRI 80 CRI 90CRI 90 CRI	27K 2700K 30K 3000K 35K 3500K 40K 4000K 50K 5000K	300LMF 300 Lumens per Foot 400LMF 400 Lumens per Foot 600LMF 600 Lumens per Foot 800LMF 800 Lumens per Foot 1000LMF 1000 Lumens per Foot 1200LMF 1200 Lumens per Foot 1400LMF 1400 Lumens per Foot 1500LMF 1500 Lumens per Foot _LMF Specify Lumens between 300LMF - 1500LMF in 50LMF increments	(blank) Lambertian WW Wallwash Distribution WG Wall Graze Distribution DBW Direct Batwing Distribution Direct Distribution options are only available with FLL lens.

--	--	--	--	--	--	--	--

Switching	Minimum Dimming Level	Direct Shielding	Voltage	Finish	Emergency Options
SCT Single Circuit	NODIM¹ Non Dimming MINI Constant Current, Dimming To 1% MINIO² Constant Current, Dimming To 10% DARK Constant Current, Dimming To 0.1% 1. Not available with Control Input options. 2. MINIO is not available with DALI, ECOD or ECOD2.	FLL Flush Lens (Default) LVRR¹ Regressed Louver LVRR¹A Regressed Louver, Natural Aluminum EGLD² Edge Glow, Direct DRP0³ Drop Lens, 1/2" DRP1¹ Drop Lens, 1" DRP1⁵ Drop Lens, 1-1/2" CLL⁴ Continuous Flush Lens 1. LVRR & LVRR ¹ A are not available with NLTAIR2. Only available in whole foot increments 2. EGLD is not available with E10WLCP, NLTAIR2 or sensors. Only available in whole foot increments. 3. Drop lenses are only available in whole foot increments. 4. CLL is not available with WW, WG, or DBW.	MVOLT Multi-Volt, 120-277 120 120V 277 277V 347¹ 347V 1. 347 is only available with ZT. 347 is not available with emergency options or sensors.	WHTT White (Satin) BLKT Black (Satin) SLVT Silver (Satin) RALTB¹D <u>RAL Paint Finish</u> 1. RALTB ¹ D is for pricing only. Replace with applicable RAL number & finish when placing order.	(blank) No Emergency Options E10WLCP¹ # of 10W Battery Packs, Constant Power, Self-Diagnostics, T20 Compliant WEC² Emergency Circuit for Entire Run _EC # of Emergency Circuits GTD³ Generator Transfer Device (Remote mounted) 1. E10WLCP is not available in units under 4'. E10WLCP with NLTAIR2 is only available in units 7'-8'. 2. WEC is not available with sensors. 3. GTD is remote mounted. (See more information on page 9.) GTD is not available with MVOLT or 347.

--	--	--	--	--	--

Control Input	Primary Sensor	Secondary Zone	Tertiary Zone	Mounting Type
(blank) Non-Dimming ZT 0-10V NLIGHT nLight Wired NLTAIR2¹ nLight Air 2 Wireless Enabled DALI² DALI ECOD³ Lutron EcoSystem Digital Driver 1. NLTAIR2 can be used as a normal power sensing device for nLight Air devices and luminaires with EM emergency options. It is not available with NODIM. NLTAIR2 with DCT fixtures cannot be less than 4'. 2. DALI is only available with DARK. DALI is not available with sensors. 3. ECOD is only available with MINI. It is not available with E10WLCP & sensors. It is only available with 300LMF, 600LMF, 1000LMF or 1500LMF.	(blank) No sensors or Zones NS_ Primary Zone with No Sensor (Specify length in feet) ADC¹ Daylight Dimming Sensor PDT¹ Dual Technology Occupancy Sensor, PIR and Microphonics Sensor APIR² Passive Infrared Occupancy and Daylight Dimming Sensor APDT² Dual Technology Occupancy and Daylight Dimming Sensor Sensors are only available with FLL and fixtures 4' and above. Please see page 8 for more details. 1. ADC & PDT are available with ZT or NLIGHT. 2. APIR & APDT are available with ZT, NLIGHT or NLTAIR2.	(blank) No Sensors or Secondary Zone SNS_ Secondary Zone with No Sensor (Specify length in feet) SADC¹ Daylight Dimming Sensor, Secondary Zone SPDT¹ Dual Technology Occupancy Sensor, PIR and Microphonics Sensor, Secondary Zone SAPIR² Passive Infrared Occupancy and Daylight Dimming Sensor, Secondary Zone SAPDT² Dual Technology Occupancy and Daylight Dimming Sensor, Secondary Zone Sensors are only available with FLL and fixtures 4' and above. Please see page 8 for more details. 1. ADC & PDT are available with ZT or NLIGHT/ 2. APIR & APDT are available with ZT, NLIGHT or NLTAIR2.	(blank) No Tertiary Zone TNS_ Tertiary Zone (Specify length in feet)	F1/ T-Bar Ceiling with Universal Mounting Bracket F1A/ T-Bar Ceiling with Universal Mounting Bracket & Integrated J-Box F2/ Hard Ceiling

--	--	--	--	--

Overall Suspension	Canopy Form	Canopy Color	Cord Color	Options
36A 36" Adjustable 72A 72" Adjustable 144A 144" Adjustable	RDCY Round Canopy SQCY Square Canopy	BLKCY Black Canopy WHTCY White Canopy SLVCY Silver Canopy	WCRD White Cord BCRD Black Cord CAT5 cord, when included, will be white.	(blank) No Options MCS Matching Support Canopy PIF¹ Feed Cord Installed BAA Manufactured in US 1. Cord length will match overall suspension length specified.

Note: Unit length and lumen outputs may affect available options.



PHOTOMETRICS



Test Report: ISF 222300P181
IES LM79-08
S4PD U4 80CRI 35K 1000LMF
Lumens: 3889.8
Wattage: 31.85
Efficacy: 122.13



Test Report: ISF 23344P181
IES LM79-08
S4PD U4 80CRI 35K 1000LMF DBW
Lumens: 3103.9
Wattage: 31.85
Efficacy: 97.45

EXPECTED LIFE: L90 @ 60,000 HOURS
CALCULATED LIFE: L80 @ 120,000 HOURS

CCT SCALING CHART

CCT	CRI	MULTIPLIER
27K	80CRI	0.94
30K	80CRI	0.97
35K	80CRI	1.00
40K	80CRI	1.02
50K	80CRI	1.04
27K	90CRI	0.79
30K	90CRI	0.81
35K	90CRI	0.83
40K	90CRI	0.84
50K	90CRI	0.88

Lumen scaling charts can be used to approximate the lumen values at different Kelvin temperatures, color rendering indices, optics or sheilding.

Example: Find base lumen value x multiplier value = new lumen value

OPTICAL SCALING CHARTS

DOWNLIGHT	
DISTRIBUTIONS	MULTIPLIER
WW	0.80
WG	0.85
DBW	0.80

**Base fixture with Lambertian distribution and flush lens*

UGR CHART

COMING SOON		
--------------------	--	--

UGR varies based on luminaire options and is affected by application dependent parameters. Numbers depicted here are considered "Luminaire-UGR" and/or "Point-UGR" values. To determine a more precise maximum UGR value ("Application-UGR"), a full lighting design layout should be completed with the selected luminaire configuration for each application.

LINEAR PLAN

Mark Lighting offers the ability to provide a continuous run plan to suit your requirements by optionally offering three different methods of configuration.

LLP- Linear Longest Possible

In this configuration, the longest length available is optimized, resulting in the fewest segments and mounting locations. Caution should be used where balanced appearance is a concern. Example: 20 FT run would have 2, 8 FT segments and 1, 4 FT segment at the end of the run.

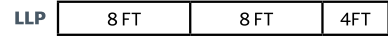

LCB- Linear Center Balanced:

This configuration incorporates the longest center segment(s) along with any additional lengths required to fill the run length, added to the run ends. Example: 16 FT run would have 2, 4 FT segments (one at each end) and 1, 8 FT segment in the center.



LSL- Linear Same Length:

In this configuration, each segment is the same length and is standardized based on the longest length available and is the only option provided. Because it is dependent on one segment length and there are mathematical limitations on what overall row lengths can be achieved. Example: 20 FT row would be achieved with 5, 4 FT long segments equaling 20 FT (nominal).

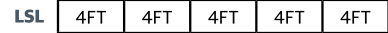

Total Run Length

This system is not modular. Runs longer than 8 FT will be automatically configured with left, intermediate and right sections, based on how you specify the TOTAL RUN LENGTH and MAXIMUM SECTION LENGTH parameters in the ordering information. Always order the total run length, not the individual sections.

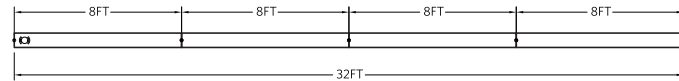

Example: This run must be ordered as 1pc "S4PD LLP 32FT MSL8..."



Example: If you order as 4pcs "S4PD LLP 8FT MSL8... you will receive these INDIVIDUAL sections that cannot be joined together

Maximum Section Length

The run will be broken out using as many sections at the chosen maximum section length as possible. Shorter sections will then complete the desired run length.

Examples:

S4PD LLP 21FT MSL5... = 5FT / 4FT / 4FT / 4FT / 4FT

S4PD LLP 21FT MSL6... = 6FT / 6FT / 5FT / 4FT

S4PD LLP 21FT MSL7... = 7FT / 7FT / 7FT

S4PD LLP 21FT MSL8... = 8FT / 8FT / 5FT

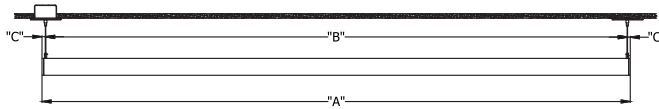

ORDERED LENGTH	INDIVIDUAL FIXTURES			APPROX. WEIGHT
	"A" O.A.L.	"B" O.C.	"C" FROM END	
2FT	2'- 0 9/16"	1'- 11 13/16"	3/8"	2
3FT	3'- 0 9/16"	2'- 11 13/16"	3/8"	3
4FT	4'- 0 9/16"	3'- 11 13/16"	3/8"	4
5FT	5'- 0 9/16"	4'- 11 13/16"	3/8"	5
6FT	6'- 0 9/16"	5'- 11 13/16"	3/8"	6
7FT	7'- 0 9/16"	6'- 11 13/16"	3/8"	7
8FT	8'- 0 9/16"	7'- 11 13/16"	3/8"	8

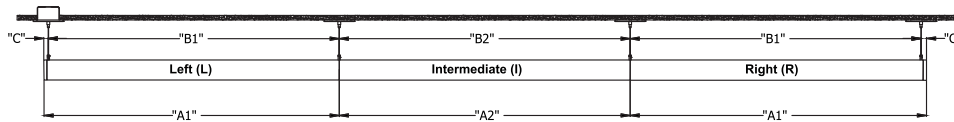

ORDERED LENGTH	RUN LAYOUT					APPROX. WEIGHT
	"A1" O.A.L.	"A2" O.A.L.	"B1" O.C.	"B2" O.C.	"C" FROM END	
4FT	4'- 0 1/4"	4'- 0"	3'- 11 15/16"	4'- 0"	3/8"	4
5FT	5'- 0 1/4"	5'- 0"	4'- 11 15/16"	5'- 0"	3/8"	5
6FT	6'- 0 1/4"	6'- 0"	5'- 11 15/16"	6'- 0"	3/8"	6
7FT	7'- 0 1/4"	7'- 0"	6'- 11 15/16"	7'- 0"	3/8"	7
8FT	8'- 0 1/4"	8'- 0"	7'- 11 15/16"	8'- 0"	3/8"	8

SHIELDING, OPTICS & CONNECTORS

Direct Shielding

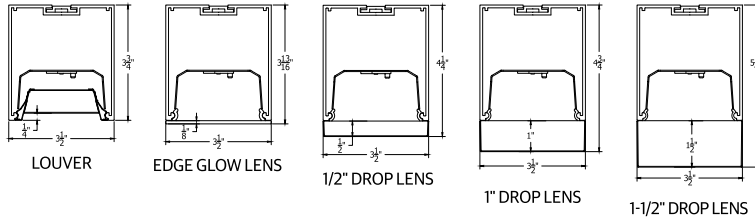

Direct Optics

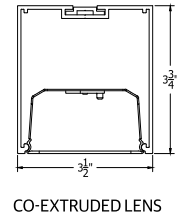

Optical Film with
Co-Extruded Lens
(Batwing (DBW),
Wall Graze (WG),
Wall Wash (WW))

Run Patterns, Corners and Junction

Patterns can be configured in 1' increments with illuminated L, T & X connectors with standard 2' corner. L connectors are available in 40-160 degrees in 1 degree increments. T & X connectors available in 90 degrees. For custom angles, corner or junction lengths, consult factory. See separate pattern spec sheet for more details.

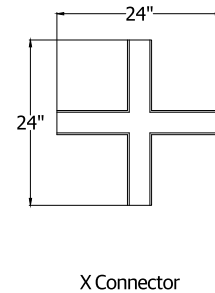
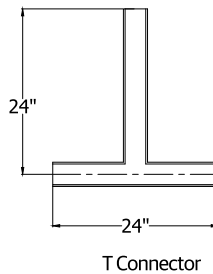
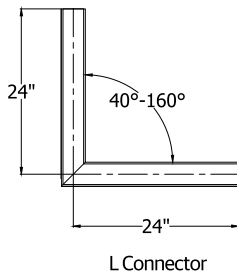

MOST COMMON MOUNTING TYPES AND OPTIONS Options available for this specific luminaire are checked in the boxes below.

Mounting Type

- F1/** For use with most T-Bar and screw slot grid ceilings. Designed for on-grid and off-grid applications. (J-box by others)
- F1A/** For use with most T-Bar grid ceilings. Designed for on-grid applications. Comes complete with J-box with built-in cutout to go over grid
- F2/** For use with recessed or surface mount horizontal J-box applications. (J-box by others)

Mounting Options

- MCS** MCS canopy supplies 5" canopy to match feed point canopy size. Matching canopy at support for aesthetics.
- PIF** Feed cord installed in fixture.

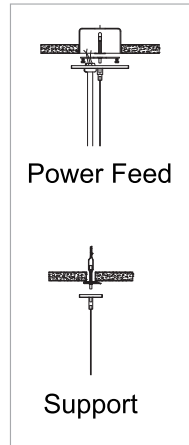

Mounting with Feed (SPSWIFK)

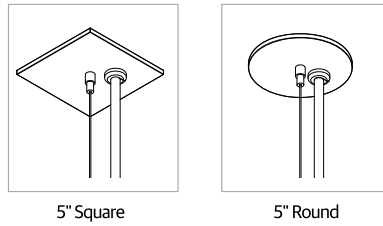

Mounting with Dual Feed (SPSW2FK)

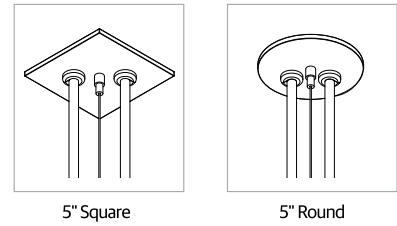

Mounting Support (SPSWSK)

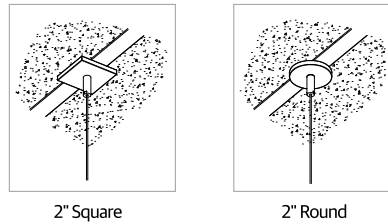

MCS Option

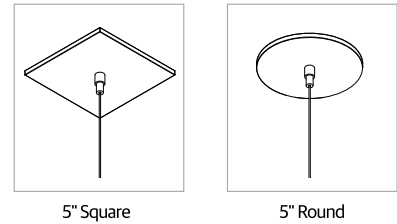

INTELLIGENT LUMINAIRE TECHNOLOGY GUIDE

Choose nomenclature from these columns				
Driver Configurations	Minimum Dimming Level	Control Input	Dimming Range	Notes
	NO DIM	(blank)	-	No 0-10V leads from the driver.
	MINIO	ZT	100 to 10%	
	MIN1	ZT	100 to 1%	
	MIN1	NLIGHT	100 to 1%	
	MIN1	ECOD	100 to 1%	Lutron Hi-lume 1% EcoSystem LED Driver with Soft-on, Fade-to-Black (model LDE1)
	DARK	ZT	100 to 0.1%	
	DARK	NLIGHT	100 to 0.1%	
	DARK	DALI	100 to 0.1%	*Compatible with DALI. Formerly (EDB & EDAB) nomenclature.* Logarithmic dimming

Choose nomenclature from these columns				
Control / Sensor Configurations	Control Input	Sensor	Sensor	Notes
	ZT	ADC	MSD ADC	Automatic dimming control integral photocell.
	ZT	PDT	MSD PDT 7	Dual technology integral occupancy sensor.
	ZT	APIR	MSD 7 ADC	PIR integral occupancy sensor with automatic dimming control photocell.
	ZT	APDT	MSD PDT 7 ADC	Dual technology integral occupancy sensor with automatic dimming control photocell.
	NLIGHT	(blank)	nIO EZ PH	nLight enabled only. No onboard sensor.
	NLIGHT	ADC	nIO EZ PH + nES ADCX	Automatic dimming control integral photocell. nLight enabled.
	NLIGHT	PDT	nIO EZ PH + nES PDT 7	360° Dual technology integral occupancy sensor. nLight enabled.
	NLIGHT	APIR	nIO EZ PH + nES 7 ADCX	360° PIR integral occupancy sensor with automatic dimming control photocell. nLight enabled.
	NLIGHT	APDT	nIO EZ PH + nES PDT 7 ADCX	360° Dual technology integral occupancy sensor with automatic dimming control photocell. nLight enabled.
	NLTAIR2	(blank)	RIO EZDL EXT900 ACWH 90D G2	nLight AIR enabled only. No onboard sensor.
	NLTAIR2	APIR	RES7 EXT900 ACWH 90D G2	PIR integral occupancy sensor with automatic dimming control photocell. nLight AIR enabled.
	NLTAIR2	APDT	RES7 PDT EXT900 ACWH 90D G2	Dual technology integral occupancy sensor with automatic dimming control photocell. nLight AIR enabled.

For more information, please consult our technical guides for [nLight](#) or [nLight Air](#).

UL924 Sequence of Operation

The below information applies to all nLight AIR devices with an EM option.

- EM devices will remain at their high-end trim and ignore wireless lighting control commands, unless a normal-power-sensed (NPS) broadcast is received at least every 8 seconds.
- Using the CLAIRITY+ mobile app, EM devices must be associated with a group that includes a normal power sensing device to receive NPS broadcasts.
- Only non-emergency rPP20, rLSXR, rSBOR, rSDGR, and nLight AIR luminaires with version 3.4 or later firmware can provide normal power sensing for EM devices. See specification sheets for control devices and luminaires for more information on options that support normal power sensing.

nLight® Wired Control Accessories <i>Order as separate catalog number</i>	
Wall Switches	Model Number
On/Off single pole	nPODMA (color)
On/Off two pole	nPODMA 2P (color)
On/Off single pole, dimming	nPODMA DX (color)
On/Off two pole, dimming	nPODMA 2P DX (color)
On/Off, two level	nPODMA 2L (color)
Graphic touchscreen	nPOD TOUCH (color)

For more information see [nPOD](#) and [nPOD TOUCH](#) spec sheets

nLight AIR® Control Accessories <i>Order as separate catalog number</i>	
Wall Switches	Model Number
On/Off single pole	rPODBA (color)
On/Off two pole	rPODBA 2P (color)
On/Off single pole, dimming	rPODBA DX (color)
On/Off two pole, dimming	rPODBA 2P DX (color)
On/Off, 4 scene control	rPODBA 4S (color)

For more information see [rPOD](#) spec sheets



Catalog Information:

S4PD-LLP-MSL8-90CRI-35K-1000LMF-SCT-MIN1-FLL-MVOLT-[FINISH]-ZT-F2/144A-RDCY-WHTCY-WCRD

Date:02/22/2023
Fixture Type:

B5

INTEGRATED SENSOR LAYOUT

For runs longer than 8FT:
ALWAYS order the run by the TOTAL RUN LENGTH. Ordering the sections individually will not provide the correct joining hardware to allow connection in the field.

CORRECT:

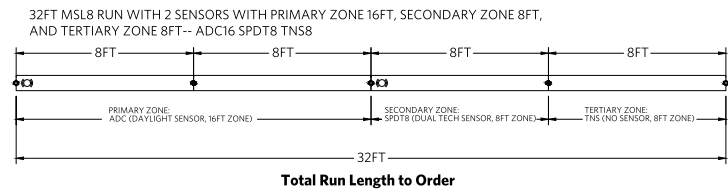
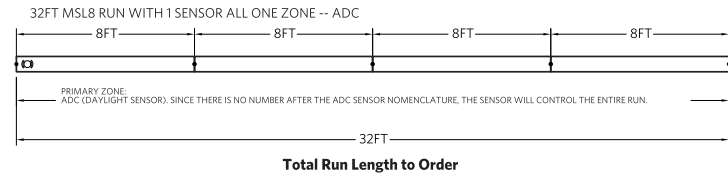
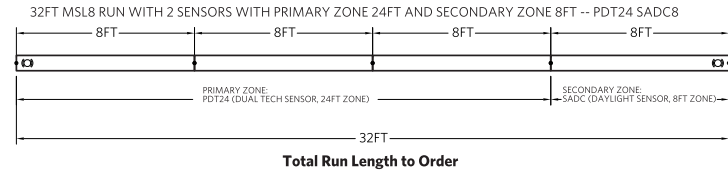

INCORRECT:

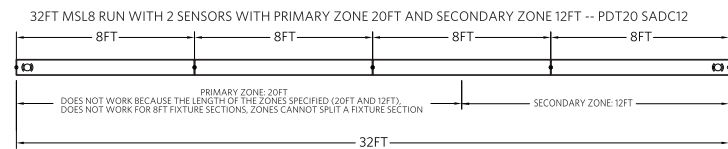
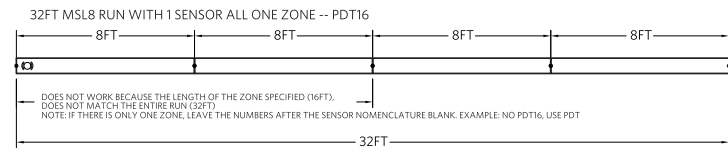

Notes:

- Only one sensor per zone
- At the most, the entire run can only have 2 sensors (thus 2 sensors zones at the most)
- Sensor zone can not split fixture sections
- No overlapping zones

OCCUPANCY DETECTION COVERAGE

At the 7.5 ft (2.9 m) hanging height of a typical pendant mount fixture the sensor provides 10 ft (3.05 m) radial detection of small motion. At a 9 ft (2.74 m) hanging height the radius is 12 ft (3.66 m) for small motion.

Adequate for walking motion detection from mounting heights between 7.5 ft (2.29 m) and 20 ft (6.10 m).

Initial detection will occur earlier when walking across sensor's field of view than when walking directly at sensor.

Initial detection of walking motion into long coverage segment will occur at distances of 2x the mounting height up to 15 ft (4.57 m) and 1.75x up to 20 ft (6.10 m). Lens assembly rotates 15° to enable adjustment in order to line up long segments.

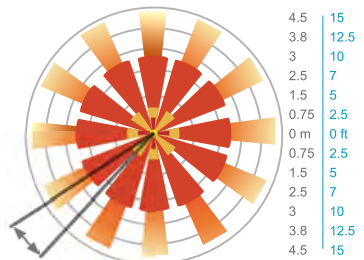

Lens rotates 15° to enable adjustment

Integrated Controls

Optional nLight® integrated controls make Slot LED luminaires addressable- allowing them to digitally communicate with other nLight enabled controls such as dimmers, switches, occupancy sensors and photocontrols. Simply connect all the nLight enabled control devices using standard CAT5 Cabling (included).

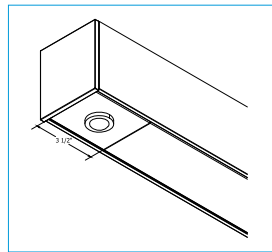

Occupancy Sensor and/or Photocell

nLight Air Wireless Antenna Location

Note: Antenna will be shipped separately and will need to be attached to the coax connector.

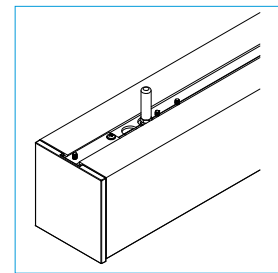

EMERGENCY OPTIONS

Emergency Battery Packs

The PS1055LCP battery is integral to the fixture and comes standard with a remote test switch and self-diagnostics. Only direct light portion operated by emergency, as indicated below.

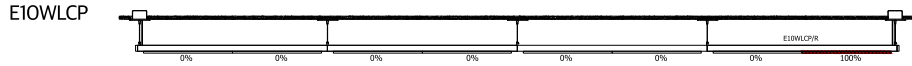

Emergency Circuits

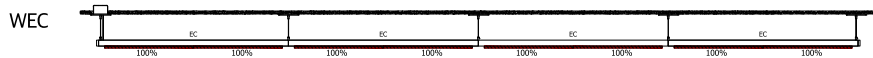
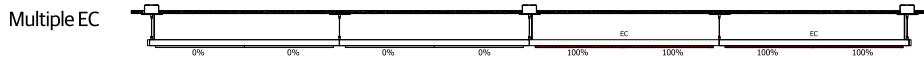
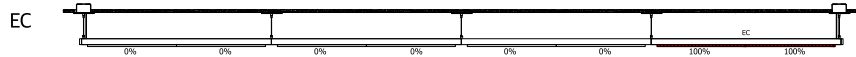

Note: Whole run on emergency circuit

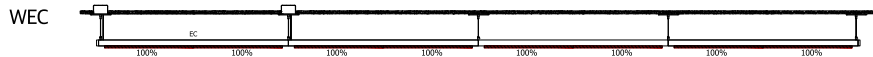

Note: Whole run on emergency circuit nltAIR2/nLight PP in first fixture

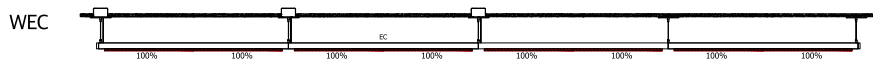

Note: Whole run on emergency circuit nltAIR2/nLight PP in second fixture

How to Estimate Delivered Lumens in Emergency Mode
Use the formula below to estimate the delivered lumens in emergency mode
Delivered Lumens = 1.25 x P x LPW
P = 10W for PS1055LCP
LPW = Lumen per watt rating of the luminaire This information is available on page 1 of this spec sheet or appropriate IES file.

Section Length	E10WLCP	EC
U2	None	Entire unit
U3	None	Entire unit
U4	Entire unit	Entire unit
U5	Last 3'	Entire unit
U6	Last 3'	Entire unit
U7	Last 4'	Entire unit
U8	Last 4'	Entire unit

Remote GTD Mounting Option

Recessed in ceiling. Consult factory for other ceiling types or canopy options. 6 foot flexible conduit included, GTD option should be mounted within 6 feet of junction box above fixture.

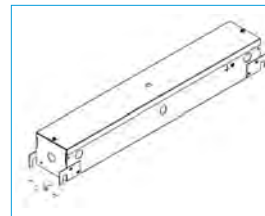
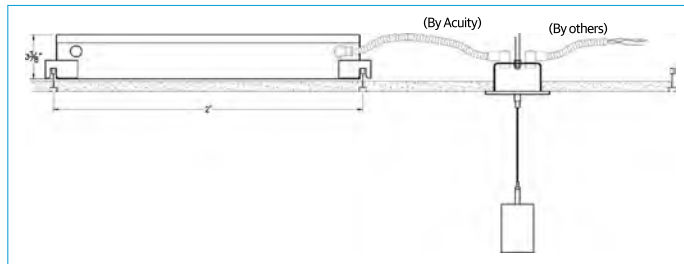

Accessible Ceiling

SPECIFICATIONS

Housing

One-piece extruded aluminum housing

Finish

Standard colors for fixtures and end caps are polyester powder coated white, black, or silver with satin sheen. Consult factory for custom colors and RAL color options.

Optics (Distribution)

Wall Wash (WW), Wall Graze (WG), and Direct Batwing (DBW) incorporate co-extruded lenses and films.

Lenses/Shielding

Direct: Extruded acrylic lens, (FLL, CLL). Edge Glow lens, (EGLD), Aluminum baffle with either a powder coat finish (LVRR) or aluminum finish (LVRRRA). Extruded acrylic drop lens (DRPO5, DRP1, DRP15).

LED Components

Multiple lumen packages available with 2700K, 3000K, 3500K, 4000K and 5000K CCT. The Acuity Brands circuit boards for the linear LED components use a precise binning algorithm which creates a consistent color temperature from board to board. The color variation of no greater than a 2.5 Step MacAdam (2.55DECM) along the black body locus from board to board.

Electrical

Long-life LEDs, coupled with high-efficiency drivers, provide superior quantity and quality of illumination for extended service life. 90% LED lumen maintenance at 60,000 hours (L90/60,000).

Circuits

Single and dual switching options available. Dual switching offered with shared neutral.

Controls System Networking Options

Optional integrated nLight® controls make each fixture addressable - allowing it to digitally communicate with other nLight enabled controls such as dimmers, switches, occupancy sensors, and photocontrols. Connection to nLight is simple. It can be accomplished with remote nLight AIR wireless or through standard Cat-5 cabling. (cabling "by others") nLight offers unique plug-and-play convenience as devices and luminaires automatically discover each other, while nLight AIR is commissioned easily through an intuitive mobile app.

Emergency Battery (Optional)

Integral emergency battery (E10WLCP) for 90 minutes of operation. Emergency battery pack, 10W, Linear Constant Power Certified in CA Title 20 MAEDBS.

Remote generator transfer device (GTD) works in conjunction with an auxiliary generator or a central inverter system to power fixtures for safe egress lighting.

Dimming Drivers

Factory tuned constant current electronic dimming driver is standard. Flicker free dimming available down to <1%. LED drivers perform within the recommended operating areas for flicker as a function of frequency and modulation (%) IEEE Standard 1789-2015 (IEEE Recommended Practices for Modulating Current in High-Brightness LEDs for Mitigating Health Risks to Viewers), in typical operating conditions at representative dimming levels. Electrical specifications at maximum driver load: PF > 0.9 and THD <20%. Meets FCC Title 47 Class A or Class B. Other available drivers include Lutron and DALI protocol drivers. All drivers are RoHS compliant.

Environment

Suitable for damp location. Indoor use only.

Certification

CSA certified to meet U.S. and Canadian standards (UL1598 and UL8750).

Ambient Operating Temperature

-20°C (-4° F) to +25°C (+77°F).

Buy American Act

Product with the BAA option is assembled in the USA and meets the Buy America(n) government procurement requirements under FAR, DFARS and DOT regulations. Please refer to www.acuitybrands.com/buy-american for additional information.

Fixture Weight

1 lbs per foot, less packaging.

Warranty

5-year limited warranty. This is the only warranty provided and no other statements in this specification sheet create any warranty of any kind. All other express and implied warranties are disclaimed. Complete warranty terms located at: www.acuitybrands.com/support/warranty/terms-and-conditions

Note: Actual performance may differ as a result of end-user environment and application.

All values are design or typical values, measured under laboratory conditions at 25 °C.

Specifications subject to change without notice.



SLOT 4

PENDANT DIRECT

HIGHLIGHTS

- 300 to 1500 lumens per foot Direct
- Up to 126 Lumens per Watt
- 5 direct distributions: Lambertian, Batwing, Wall Wash, Wall Graze or Asymmetric
- Multiple lens treatment options include Continuous, Drop, in 1/2", 1" or 1 1/2" and Edge View
- Shielding provided by optional deep cell baffle
- Integrated control with optional nLight or nLight Air for system networking
- Driver options for Dim to Dark, 1% or 10% minimum dimming
- White, black or silver paint with satin finish
- Declare listed
- UGR data available on page 3

DIMENSIONS

See page 5 for additional details.

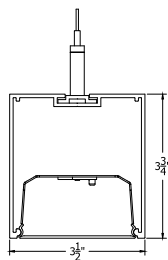

FIXTURE PERFORMANCE

Nominal Lumens/Foot	Direct							
	300LMF	400LMF	600LMF	800LMF	1000LMF	1200LMF	1400LMF	1500LMF
Delivered Lumens/Foot	292	394	575	791	973	1192	1352	1442
Input Watts/Foot	2.39	3.14	4.68	6.33	7.96	10.00	11.93	13.01
Lumens/Watt	122	126	123	125	122	119	113	111

Based on 4FT, 80CRI, 35K with standard Lambertian distribution.



DIRECT DISTRIBUTION

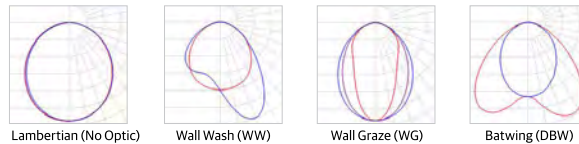

DIFFUSERS/SHIELDING

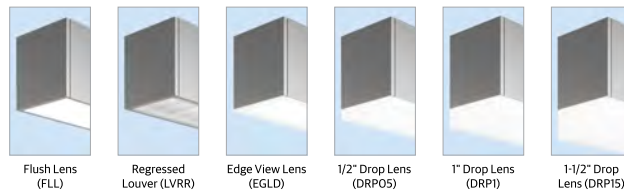

ORDERING

Example: S4PD LLP 32FT MSL8 90CRI 35K 800LMF MINI FLL SCT MVOLT WHTT ZT F1/36A RDCY WHTCY WCRD

Series	Linear Plan	Total Run Length	Max Section Length	Direct Light Source Color Rendering	Direct LED Color Temp	Direct LED Light Output	Direct Distribution (Optics)
S4PD SLOT 4 Pendant Direct (Formerly S4LD)	LLP Linear Longest Possible LCB Linear Center Balanced LSL Longest Same Length For more information on linear plans, see page 4.	_FT Specify Continuous Run Length (in 1" increments, 2' minimum) Unit length may affect available options. For runs longer than 8FT: ALWAYS order the sections individually will not provide the correct joining hardware to allow connection in the field.	MSL2 2FT Length MSL3 3FT Length MSL4 4FT Length MSL5 5FT Length MSL6 6FT Length MSL7 7FT Length MSL8 8FT Length	80CRI 80CRI 90CRI 90CRI	27K 2700K 30K 3000K 35K 3500K 40K 4000K 50K 5000K	300LMF 300 Lumens per Foot 400LMF 400 Lumens per Foot 600LMF 600 Lumens per Foot 800LMF 800 Lumens per Foot 1000LMF 1000 Lumens per Foot 1200LMF 1200 Lumens per Foot 1400LMF 1400 Lumens per Foot 1500LMF 1500 Lumens per Foot _LMF Specify Lumens between 300LMF - 1500LMF in 50LMF increments	(blank) Lambertian WW Wallwash Distribution WG Wall Graze Distribution DBW Direct Batwing Distribution Direct Distribution options are only available with FLL lens.

Switching	Minimum Dimming Level	Direct Shielding	Voltage	Finish	Emergency Options
SCT Single Circuit	NODIM¹ Non Dimming MINI Constant Current, Dimming To 1% MINIO² Constant Current, Dimming To 10% DARK Constant Current, Dimming To 0.1% 1. Not available with Control Input options. 2. MINIO is not available with DALI, ECOD or ECOD2.	FLL Flush Lens (Default) LVRR¹ Regressed Louver LVRR¹A Regressed Louver, Natural Aluminum EGLD² Edge Glow, Direct DRP0³ Drop Lens, 1/2" DRP1¹ Drop Lens, 1" DRP1⁵ Drop Lens, 1-1/2" CLL⁴ Continuous Flush Lens 1. LVRR & LVRR ¹ A are not available with NLTAIR2. Only available in whole foot increments 2. EGLD is not available with E10WLCP, NLTAIR2 or sensors. Only available in whole foot increments. 3. Drop lenses are only available in whole foot increments. 4. CLL is not available with WW, WG, or DBW.	MVOLT Multi-Volt, 120-277 120 120V 277 277V 347¹ 347V 1. 347 is only available with ZT. 347 is not available with emergency options or sensors.	WHTT White (Satin) BLKT Black (Satin) SLVT Silver (Satin) RALTB¹D¹ RAL Paint Finish 1. RALTB ¹ D is for pricing only. Replace with applicable RAL number & finish when placing order.	(blank) No Emergency Options E10WLCP¹ # of 10W Battery Packs, Constant Power, Self-Diagnostics, T20 Compliant WEC² Emergency Circuit for Entire Run _EC # of Emergency Circuits GTD³ Generator Transfer Device (Remote mounted) 1. E10WLCP is not available in units under 4'. E10WLCP with NLTAIR2 is only available in units 7'-8'. 2. WEC is not available with sensors. 3. GTD is remote mounted. (See more information on page 9.) GTD is not available with MVOLT or 347.

Control Input	Primary Sensor	Secondary Zone	Tertiary Zone	Mounting Type
(blank) Non-Dimming ZT 0-10V NLIGHT nLight Wired NLTAIR2¹ nLight Air 2 Wireless Enabled DALI² DALI ECOD³ Lutron EcoSystem Digital Driver 1. NLTAIR2 can be used as a normal power sensing device for nLight Air devices and luminaires with EM emergency options. It is not available with NODIM. NLTAIR2 with DCT fixtures cannot be less than 4'. 2. DALI is only available with DARK. DALI is not available with sensors. 3. ECOD is only available with MINI. It is not available with E10WLCP & sensors. It is only available with 300LMF, 600LMF, 1000LMF or 1500LMF.	(blank) No sensors or Zones NS_ Primary Zone with No Sensor (Specify length in feet) ADC¹ Daylight Dimming Sensor PDT¹ Dual Technology Occupancy Sensor, PIR and Microphonics Sensor APIR² Passive Infrared Occupancy and Daylight Dimming Sensor APDT² Dual Technology Occupancy and Daylight Dimming Sensor Sensors are only available with FLL and fixtures 4' and above. Please see page 8 for more details. 1. ADC & PDT are available with ZT or NLIGHT. 2. APIR & APDT are available with ZT, NLIGHT or NLTAIR2.	(blank) No Sensors or Secondary Zone SNS_ Secondary Zone with No Sensor (Specify length in feet) SADC¹ Daylight Dimming Sensor, Secondary Zone SPDT¹ Dual Technology Occupancy Sensor, PIR and Microphonics Sensor, Secondary Zone SAPIR² Passive Infrared Occupancy and Daylight Dimming Sensor, Secondary Zone SAPDT² Dual Technology Occupancy and Daylight Dimming Sensor, Secondary Zone Sensors are only available with FLL and fixtures 4' and above. Please see page 8 for more details. 1. ADC & PDT are available with ZT or NLIGHT/ 2. APIR & APDT are available with ZT, NLIGHT or NLTAIR2.	(blank) No Tertiary Zone TNS_ Tertiary Zone (Specify length in feet)	F1/ T-Bar Ceiling with Universal Mounting Bracket F1A/ T-Bar Ceiling with Universal Mounting Bracket & Integrated J-Box F2/ Hard Ceiling

Overall Suspension	Canopy Form	Canopy Color	Cord Color	Options
36A 36" Adjustable 72A 72" Adjustable 144A 144" Adjustable	RDCY Round Canopy SQCY Square Canopy	BLKCY Black Canopy WHTCY White Canopy SLVCY Silver Canopy	WCRD White Cord BCRD Black Cord CAT5 cord, when included, will be white.	(blank) No Options MCS Matching Support Canopy PIF¹ Feed Cord Installed BAA Manufactured in US 1. Cord length will match overall suspension length specified.

Note: Unit length and lumen outputs may affect available options.



Catalog Information:

S4PD-LLP-MSL6-90CRI-35K-1000LMF-SCT-MIN1-FLL-MVOLT-WHTT-ZT-F2/144A-RDCY-WHTCY-WCRD

Date: 02/22/2023
Fixture Type:

B5A

PHOTOMETRICS



Test Report: ISF 222300P181
IES LM79-08
S4PD U4 80CRI 35K 1000LMF
Lumens: 3889.8
Wattage: 31.85
Efficacy: 122.13



Test Report: ISF 23344P181
IES LM79-08
S4PD U4 80CRI 35K 1000LMF DBW
Lumens: 3103.9
Wattage: 31.85
Efficacy: 97.45

EXPECTED LIFE: L90 @ 60,000 HOURS
CALCULATED LIFE: L80 @ 120,000 HOURS

CCT SCALING CHART

CCT	CRI	MULTIPLIER
27K	80CRI	0.94
30K	80CRI	0.97
35K	80CRI	1.00
40K	80CRI	1.02
50K	80CRI	1.04
27K	90CRI	0.79
30K	90CRI	0.81
35K	90CRI	0.83
40K	90CRI	0.84
50K	90CRI	0.88

Lumen scaling charts can be used to approximate the lumen values at different Kelvin temperatures, color rendering indices, optics or sheilding.

Example: Find base lumen value x multiplier value = new lumen value

OPTICAL SCALING CHARTS

DOWNLIGHT	
DISTRIBUTIONS	MULTIPLIER
WW	0.80
WG	0.85
DBW	0.80

**Base fixture with Lambertian distribution and flush lens*

UGR CHART

COMING SOON		
--------------------	--	--

UGR varies based on luminaire options and is affected by application dependent parameters. Numbers depicted here are considered "Luminaire-UGR" and/or "Point-UGR" values. To determine a more precise maximum UGR value ("Application-UGR"), a full lighting design layout should be completed with the selected luminaire configuration for each application.

LINEAR PLAN

Mark Lighting offers the ability to provide a continuous run plan to suit your requirements by optionally offering three different methods of configuration.

LLP- Linear Longest Possible

In this configuration, the longest length available is optimized, resulting in the fewest segments and mounting locations. Caution should be used where balanced appearance is a concern. Example: 20 FT run would have 2, 8 FT segments and 1, 4 FT segment at the end of the run.

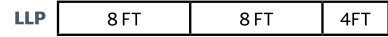

LCB- Linear Center Balanced:

This configuration incorporates the longest center segment(s) along with any additional lengths required to fill the run length, added to the run ends. Example: 16 FT run would have 2, 4 FT segments (one at each end) and 1, 8 FT segment in the center.



LSL- Linear Same Length:

In this configuration, each segment is the same length and is standardized based on the longest length available and is the only option provided. Because it is dependent on one segment length and there are mathematical limitations on what overall row lengths can be achieved. Example: 20 FT row would be achieved with 5, 4 FT long segments equaling 20 FT (nominal).

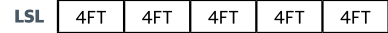

Total Run Length

This system is not modular. Runs longer than 8 FT will be automatically configured with left, intermediate and right sections, based on how you specify the TOTAL RUN LENGTH and MAXIMUM SECTION LENGTH parameters in the ordering information. Always order the total run length, not the individual sections.

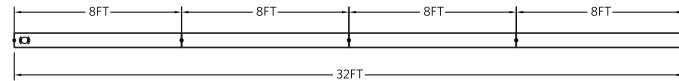

Example: This run must be ordered as 1pc "S4PD LLP 32FT MSL8..."



Example: If you order as 4pcs "S4PD LLP 8FT MSL8... you will receive these INDIVIDUAL sections that cannot be joined together

Maximum Section Length

The run will be broken out using as many sections at the chosen maximum section length as possible. Shorter sections will then complete the desired run length.

Examples:

S4PD LLP 21FT MSL5... = 5FT / 4FT / 4FT / 4FT / 4FT

S4PD LLP 21FT MSL6... = 6FT / 6FT / 5FT / 4FT

S4PD LLP 21FT MSL7... = 7FT / 7FT / 7FT

S4PD LLP 21FT MSL8... = 8FT / 8FT / 5FT

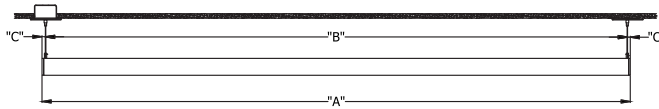

ORDERED LENGTH	INDIVIDUAL FIXTURES			APPROX. WEIGHT
	"A" O.A.L.	"B" O.C.	"C" FROM END	
2FT	2'-0 9/16"	1'-11 13/16"	3/8"	2
3FT	3'-0 9/16"	2'-11 13/16"	3/8"	3
4FT	4'-0 9/16"	3'-11 13/16"	3/8"	4
5FT	5'-0 9/16"	4'-11 13/16"	3/8"	5
6FT	6'-0 9/16"	5'-11 13/16"	3/8"	6
7FT	7'-0 9/16"	6'-11 13/16"	3/8"	7
8FT	8'-0 9/16"	7'-11 13/16"	3/8"	8

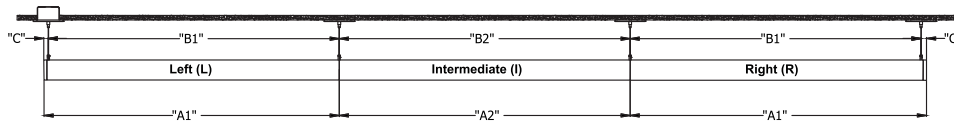

ORDERED LENGTH	RUN LAYOUT					APPROX. WEIGHT
	"A1" O.A.L.	"A2" O.A.L.	"B1" O.C.	"B2" O.C.	"C" FROM END	
4FT	4'-0 1/4"	4'-0"	3'-11 15/16"	4'-0"	3/8"	4
5FT	5'-0 1/4"	5'-0"	4'-11 15/16"	5'-0"	3/8"	5
6FT	6'-0 1/4"	6'-0"	5'-11 15/16"	6'-0"	3/8"	6
7FT	7'-0 1/4"	7'-0"	6'-11 15/16"	7'-0"	3/8"	7
8FT	8'-0 1/4"	8'-0"	7'-11 15/16"	8'-0"	3/8"	8

SHIELDING, OPTICS & CONNECTORS

Direct Shielding

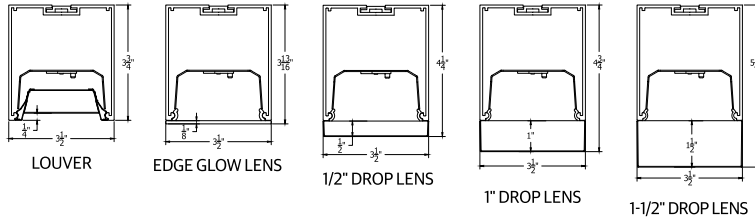

Direct Optics

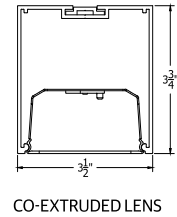

Optical Film with
Co-Extruded Lens
(Batwing (DBW),
Wall Graze (WG),
Wall Wash (WW))

Run Patterns, Corners and Junction

Patterns can be configured in 1' increments with illuminated L, T & X connectors with standard 2' corner. L connectors are available in 40-160 degrees in 1 degree increments. T & X connectors available in 90 degrees. For custom angles, corner or junction lengths, consult factory. See separate pattern spec sheet for more details.

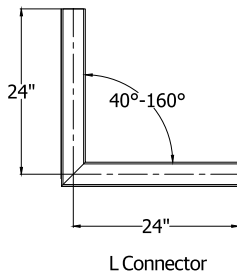

L Connector

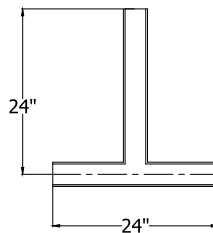

T Connector

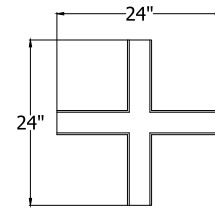

X Connector

MOST COMMON MOUNTING TYPES AND OPTIONS Options available for this specific luminaire are checked in the boxes below.

Mounting Type

- F1/** For use with most T-Bar and screw slot grid ceilings. Designed for on-grid and off-grid applications. (J-box by others)
- F1A/** For use with most T-Bar grid ceilings. Designed for on-grid applications. Comes complete with J-box with built-in cutout to go over grid
- F2/** For use with recessed or surface mount horizontal J-box applications. (J-box by others)

Mounting Options

- MCS** MCS canopy supplies 5" canopy to match feed point canopy size. Matching canopy at support for aesthetics.
- PIF** Feed cord installed in fixture.

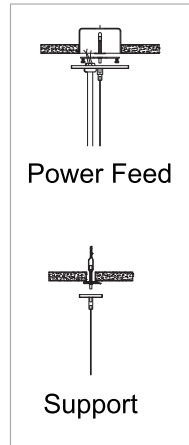

Mounting with Feed (SPSWIFK)

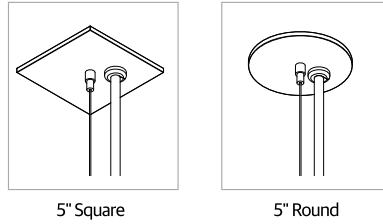

Mounting with Dual Feed (SPSW2FK)

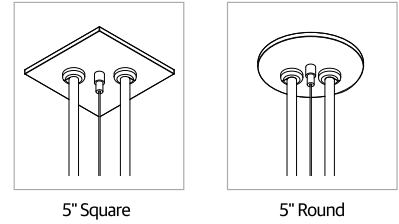

Mounting Support (SPSWSK)

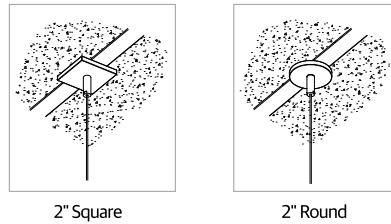

MCS Option

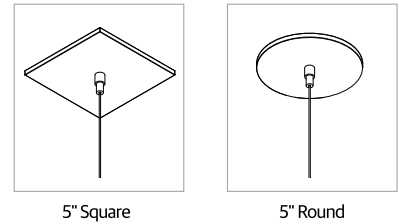

INTELLIGENT LUMINAIRE TECHNOLOGY GUIDE

Choose nomenclature from these columns				
Driver Configurations	Minimum Dimming Level	Control Input	Dimming Range	Notes
	NO DIM	(blank)	-	No 0-10V leads from the driver.
	MINIO	ZT	100 to 10%	
	MIN1	ZT	100 to 1%	
	MIN1	NLIGHT	100 to 1%	
	MIN1	ECOD	100 to 1%	Lutron Hi-lume 1% EcoSystem LED Driver with Soft-on, Fade-to-Black (model LDE1)
	DARK	ZT	100 to 0.1%	
	DARK	NLIGHT	100 to 0.1%	
	DARK	DALI	100 to 0.1%	*Compatible with DALI. Formerly (EDB & EDAB) nomenclature.* Logarithmic dimming

Choose nomenclature from these columns				
Control / Sensor Configurations	Control Input	Sensor	Sensor	Notes
	ZT	ADC	MSD ADC	Automatic dimming control integral photocell.
	ZT	PDT	MSD PDT 7	Dual technology integral occupancy sensor.
	ZT	APIR	MSD 7 ADC	PIR integral occupancy sensor with automatic dimming control photocell.
	ZT	APDT	MSD PDT 7 ADC	Dual technology integral occupancy sensor with automatic dimming control photocell.
	NLIGHT	(blank)	nIO EZ PH	nLight enabled only. No onboard sensor.
	NLIGHT	ADC	nIO EZ PH + nES ADCX	Automatic dimming control integral photocell. nLight enabled.
	NLIGHT	PDT	nIO EZ PH + nES PDT 7	360° Dual technology integral occupancy sensor. nLight enabled.
	NLIGHT	APIR	nIO EZ PH + nES 7 ADCX	360° PIR integral occupancy sensor with automatic dimming control photocell. nLight enabled.
	NLIGHT	APDT	nIO EZ PH + nES PDT 7 ADCX	360° Dual technology integral occupancy sensor with automatic dimming control photocell. nLight enabled.
	NLTAIR2	(blank)	RIO EZDL EXT900 ACWH 90D G2	nLight AIR enabled only. No onboard sensor.
	NLTAIR2	APIR	RES7 EXT900 ACWH 90D G2	PIR integral occupancy sensor with automatic dimming control photocell. nLight AIR enabled.
	NLTAIR2	APDT	RES7 PDT EXT900 ACWH 90D G2	Dual technology integral occupancy sensor with automatic dimming control photocell. nLight AIR enabled.

For more information, please consult our technical guides for [nLight](#) or [nLight Air](#).

UL924 Sequence of Operation

The below information applies to all nLight AIR devices with an EM option.

- EM devices will remain at their high-end trim and ignore wireless lighting control commands, unless a normal-power-sensed (NPS) broadcast is received at least every 8 seconds.
- Using the **CLAIRITY+** mobile app, EM devices must be associated with a group that includes a normal power sensing device to receive NPS broadcasts.
- Only non-emergency rPP20, rLSXR, rSBOR, rSDGR, and nLight AIR luminaires with version 3.4 or later firmware can provide normal power sensing for EM devices. See specification sheets for control devices and luminaires for more information on options that support normal power sensing.

nLight® Wired Control Accessories <i>Order as separate catalog number</i>	
Wall Switches	Model Number
On/Off single pole	nPODMA (color)
On/Off two pole	nPODMA 2P (color)
On/Off single pole, dimming	nPODMA DX (color)
On/Off two pole, dimming	nPODMA 2P DX (color)
On/Off, two level	nPODMA 2L (color)
Graphic touchscreen	nPOD TOUCH (color)

For more information see [nPOD](#) and [nPOD TOUCH](#) spec sheets

nLight AIR® Control Accessories <i>Order as separate catalog number</i>	
Wall Switches	Model Number
On/Off single pole	rPODBA (color)
On/Off two pole	rPODBA 2P (color)
On/Off single pole, dimming	rPODBA DX (color)
On/Off two pole, dimming	rPODBA 2P DX (color)
On/Off, 4 scene control	rPODBA 4S (color)

For more information see [rPOD](#) spec sheets



Catalog Information:

S4PD-LLP-MSL6-90CRI-35K-1000LMF-SCT-MIN1-FLL-MVOLT-WHTT-ZT-F2/144A-RDCY-WHTCY-WCRD

Date:02/22/2023
Fixture Type:

B5A

INTEGRATED SENSOR LAYOUT

For runs longer than 8FT:
ALWAYS order the run by the TOTAL RUN LENGTH. Ordering the sections individually will not provide the correct joining hardware to allow connection in the field.

CORRECT:

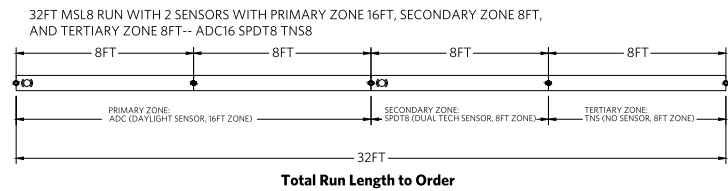
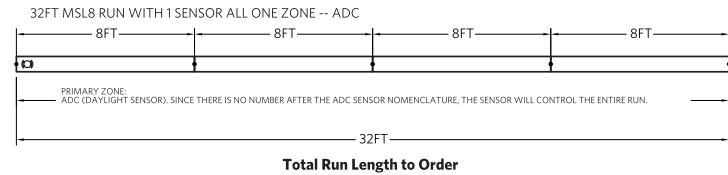
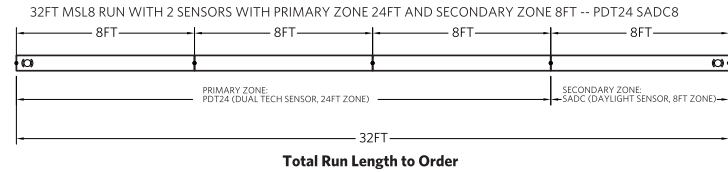

INCORRECT:

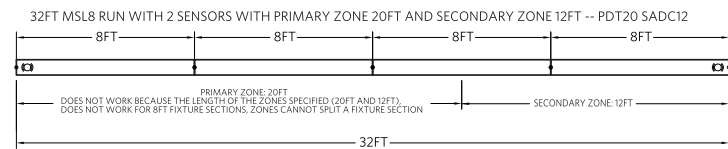
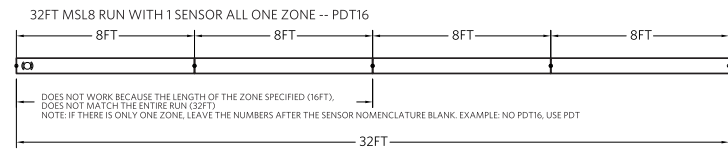

Notes:

- Only one sensor per zone
- At the most, the entire run can only have 2 sensors (thus 2 sensors zones at the most)
- Sensor zone can not split fixture sections
- No overlapping zones

OCCUPANCY DETECTION COVERAGE

At the 7.5 ft (2.9 m) hanging height of a typical pendant mount fixture the sensor provides 10 ft (3.05 m) radial detection of small motion. At a 9 ft (2.74 m) hanging height the radius is 12 ft (3.66 m) for small motion.

Adequate for walking motion detection from mounting heights between 7.5 ft (2.29 m) and 20 ft (6.10 m).

Initial detection will occur earlier when walking across sensor's field of view than when walking directly at sensor.

Initial detection of walking motion into long coverage segment will occur at distances of 2x the mounting height up to 15 ft (4.57 m) and 1.75x up to 20 ft (6.10 m). Lens assembly rotates 15° to enable adjustment in order to line up long segments.

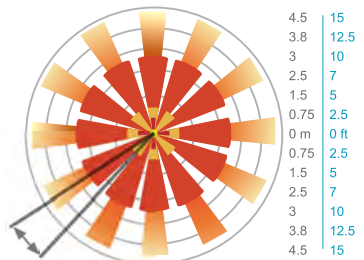

Lens rotates 15° to enable adjustment

Integrated Controls

Optional nLight® integrated controls make Slot LED luminaires addressable- allowing them to digitally communicate with other nLight enabled controls such as dimmers, switches, occupancy sensors and photocontrols. Simply connect all the nLight enabled control devices using standard CAT5 Cabling (included).

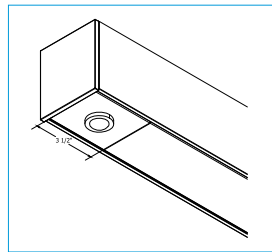

Occupancy Sensor and/or Photocell

nLight Air Wireless Antenna Location

Note: Antenna will be shipped separately and will need to be attached to the coax connector.

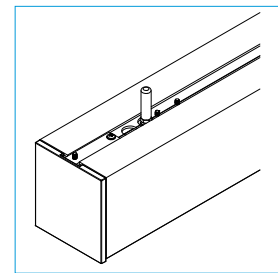

EMERGENCY OPTIONS

Emergency Battery Packs

The PS1055LCP battery is integral to the fixture and comes standard with a remote test switch and self-diagnostics. Only direct light portion operated by emergency, as indicated below.

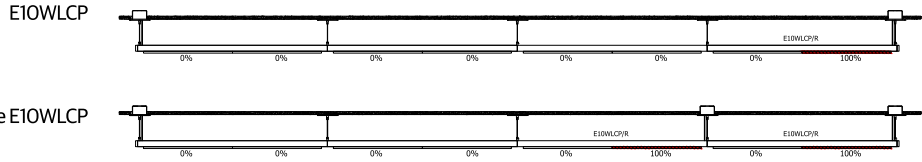

Emergency Circuits

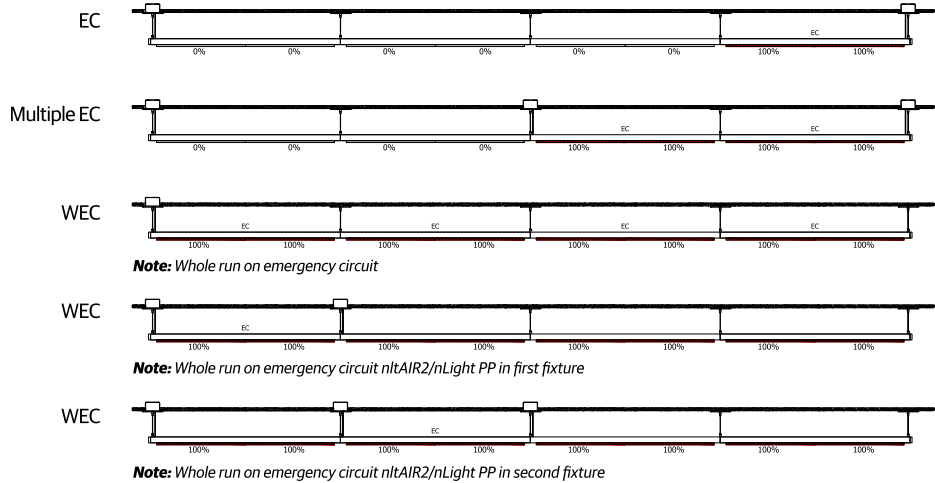

How to Estimate Delivered Lumens in Emergency Mode
Use the formula below to estimate the delivered lumens in emergency mode
Delivered Lumens = 1.25 x P x LPW
P = 10W for PS1055LCP
LPW = Lumen per watt rating of the luminaire This information is available on page 1 of this spec sheet or appropriate IES file.

Section Length	E10WLCP	EC
U2	None	Entire unit
U3	None	Entire unit
U4	Entire unit	Entire unit
U5	Last 3'	Entire unit
U6	Last 3'	Entire unit
U7	Last 4'	Entire unit
U8	Last 4'	Entire unit

Remote GTD Mounting Option

Recessed in ceiling. Consult factory for other ceiling types or canopy options. 6 foot flexible conduit included, GTD option should be mounted within 6 feet of junction box above fixture.

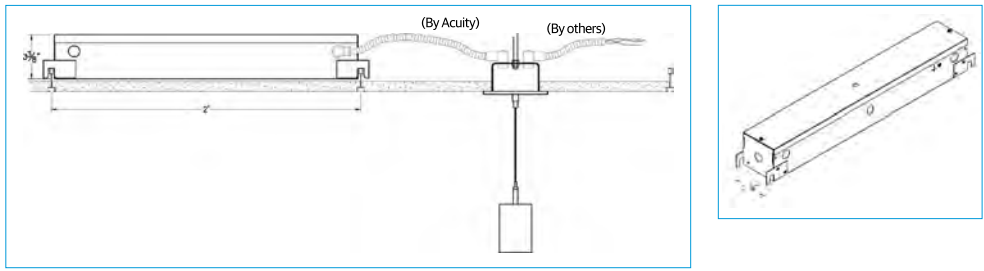

Accessible Ceiling

SPECIFICATIONS

Housing

One-piece extruded aluminum housing

Finish

Standard colors for fixtures and end caps are polyester powder coated white, black, or silver with satin sheen. Consult factory for custom colors and RAL color options.

Optics (Distribution)

Wall Wash (WW), Wall Graze (WG), and Direct Batwing (DBW) incorporate co-extruded lenses and films.

Lenses/Shielding

Direct: Extruded acrylic lens, (FLL, CLL). Edge Glow lens, (EGLD), Aluminum baffle with either a powder coat finish (LVRR) or aluminum finish (LVRRRA). Extruded acrylic drop lens (DRPO5, DRP1, DRP15).

LED Components

Multiple lumen packages available with 2700K, 3000K, 3500K, 4000K and 5000K CCT. The Acuity Brands circuit boards for the linear LED components use a precise binning algorithm which creates a consistent color temperature from board to board. The color variation of no greater than a 2.5 Step MacAdam (2.55DECM) along the black body locus from board to board.

Electrical

Long-life LEDs, coupled with high-efficiency drivers, provide superior quantity and quality of illumination for extended service life. 90% LED lumen maintenance at 60,000 hours (L90/60,000).

Circuits

Single and dual switching options available. Dual switching offered with shared neutral.

Controls System Networking Options

Optional integrated nLight® controls make each fixture addressable - allowing it to digitally communicate with other nLight enabled controls such as dimmers, switches, occupancy sensors, and photocontrols. Connection to nLight is simple. It can be accomplished with remote nLight AIR wireless or through standard Cat-5 cabling. (cabling "by others") nLight offers unique plug-and-play convenience as devices and luminaires automatically discover each other, while nLight AIR is commissioned easily through an intuitive mobile app.

Emergency Battery (Optional)

Integral emergency battery (E10WLCP) for 90 minutes of operation. Emergency battery pack, 10W, Linear Constant Power Certified in CA Title 20 MAEDBS.

Remote generator transfer device (GTD) works in conjunction with an auxiliary generator or a central inverter system to power fixtures for safe egress lighting.

Dimming Drivers

Factory tuned constant current electronic dimming driver is standard. Flicker free dimming available down to <1%. LED drivers perform within the recommended operating areas for flicker as a function of frequency and modulation (%) IEEE Standard 1789-2015 (IEEE Recommended Practices for Modulating Current in High-Brightness LEDs for Mitigating Health Risks to Viewers), in typical operating conditions at representative dimming levels. Electrical specifications at maximum driver load: PF > 0.9 and THD <20%. Meets FCC Title 47 Class A or Class B. Other available drivers include Lutron and DALI protocol drivers. All drivers are RoHS compliant.

Environment

Suitable for damp location. Indoor use only.

Certification

CSA certified to meet U.S. and Canadian standards (UL1598 and UL8750).

Ambient Operating Temperature

-20°C (-4° F) to +25°C (+77°F).

Buy American Act

Product with the BAA option is assembled in the USA and meets the Buy America(n) government procurement requirements under FAR, DFARS and DOT regulations. Please refer to www.acuitybrands.com/buy-american for additional information.

Fixture Weight

1 lbs per foot, less packaging.

Warranty

5-year limited warranty. This is the only warranty provided and no other statements in this specification sheet create any warranty of any kind. All other express and implied warranties are disclaimed. Complete warranty terms located at: www.acuitybrands.com/support/warranty/terms-and-conditions

Note: Actual performance may differ as a result of end-user environment and application.

All values are design or typical values, measured under laboratory conditions at 25 °C.

Specifications subject to change without notice.



SLOT 4

PENDANT DIRECT

HIGHLIGHTS

- 300 to 1500 lumens per foot Direct
- Up to 126 Lumens per Watt
- 5 direct distributions: Lambertian, Batwing, Wall Wash, Wall Graze or Asymmetric
- Multiple lens treatment options include Continuous, Drop, in 1/2", 1" or 1 1/2" and Edge View
- Shielding provided by optional deep cell baffle
- Integrated control with optional nLight or nLight Air for system networking
- Driver options for Dim to Dark, 1% or 10% minimum dimming
- White, black or silver paint with satin finish
- Declare listed
- UGR data available on page 3

DIMENSIONS

See page 5 for additional details.

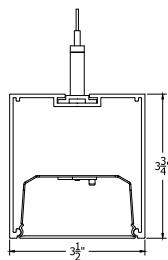

FIXTURE PERFORMANCE

Nominal Lumens/Foot	Direct							
	300LMF	400LMF	600LMF	800LMF	1000LMF	1200LMF	1400LMF	1500LMF
Delivered Lumens/Foot	292	394	575	791	973	1192	1352	1442
Input Watts/Foot	2.39	3.14	4.68	6.33	7.96	10.00	11.93	13.01
Lumens/Watt	122	126	123	125	122	119	113	111

Based on 4FT, 80CRI, 35K with standard Lambertian distribution.



DIRECT DISTRIBUTION

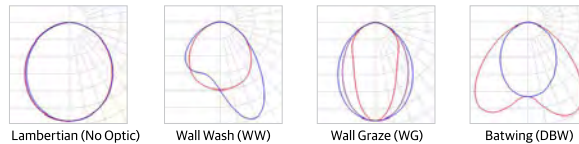

DIFFUSERS/SHIELDING

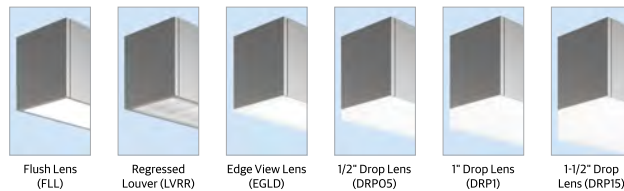

ORDERING

Example: S4PD LLP 32FT MSL8 90CRI 35K 800LMF MINI FLL SCT MVOLT WHTT ZT F1/36A RDCY WHTCY WCRD

Series	Linear Plan	Total Run Length	Max Section Length	Direct Light Source Color Rendering	Direct LED Color Temp	Direct LED Light Output	Direct Distribution (Optics)
S4PD SLOT 4 Pendant Direct (Formerly S4LD)	LLP Linear Longest Possible LCB Linear Center Balanced LSL Longest Same Length For more information on linear plans, see page 4.	_FT Specify Continuous Run Length (in 1" increments, 2" minimum) Unit length may affect available options. For runs longer than 8FT: ALWAYS order the sections individually will not provide the correct joining hardware to allow connection in the field.	MSL2 2FT Length MSL3 3FT Length MSL4 4FT Length MSL5 5FT Length MSL6 6FT Length MSL7 7FT Length MSL8 8FT Length	80CRI 80 CRI 90CRI 90 CRI	27K 2700K 30K 3000K 35K 3500K 40K 4000K 50K 5000K	300LMF 300 Lumens per Foot 400LMF 400 Lumens per Foot 600LMF 600 Lumens per Foot 800LMF 800 Lumens per Foot 1000LMF 1000 Lumens per Foot 1200LMF 1200 Lumens per Foot 1400LMF 1400 Lumens per Foot 1500LMF 1500 Lumens per Foot _LMF Specify Lumens between 300LMF - 1500LMF in 50LMF increments	(blank) Lambertian WW Wallwash Distribution WG Wall Graze Distribution DBW Direct Batwing Distribution Direct Distribution options are only available with FLL lens.

Switching	Minimum Dimming Level	Direct Shielding	Voltage	Finish	Emergency Options
SCT Single Circuit	NODIM¹ Non Dimming MINI Constant Current, Dimming To 1% MINIO² Constant Current, Dimming To 10% DARK Constant Current, Dimming To 0.1% 1. Not available with Control Input options. 2. MINIO is not available with DALI, ECOD or ECOD2.	FLL Flush Lens (Default) LVRR¹ Regressed Louver LVRR¹A Regressed Louver, Natural Aluminum EGLD² Edge Glow, Direct DRPO³ Drop Lens, 1/2" DRP¹ Drop Lens, 1" DRP¹S Drop Lens, 1-1/2" CLL⁴ Continuous Flush Lens 1. LVRR & LVRR ¹ A are not available with NLTAIR2. Only available in whole foot increments 2. EGLD is not available with E10WLCP, NLTAIR2 or sensors. Only available in whole foot increments. 3. Drop lenses are only available in whole foot increments. 4. CLL is not available with WW, WG, or DBW.	MVOLT Multi-Volt, 120-277 120 120V 277 277V 347¹ 347V 1. 347 is only available with ZT. 347 is not available with emergency options or sensors.	WHTT White (Satin) BLKT Black (Satin) SLVT Silver (Satin) RALTB¹D RAL Paint Finish 1. RALTB ¹ D is for pricing only. Replace with applicable RAL number & finish when placing order.	(blank) No Emergency Options E10WLCP¹ # of 10W Battery Packs, Constant Power, Self-Diagnostics, T20 Compliant WEC² Emergency Circuit for Entire Run _EC # of Emergency Circuits GTD³ Generator Transfer Device (Remote mounted) 1. E10WLCP is not available in units under 4'. E10WLCP with NLTAIR2 is only available in units 7'-8'. 2. WEC is not available with sensors. 3. GTD is remote mounted. (See more information on page 9.) GTD is not available with MVOLT or 347.

Control Input	Primary Sensor	Secondary Zone	Tertiary Zone	Mounting Type
(blank) Non-Dimming ZT 0-10V NLIGHT nLight Wired NLTAIR2¹ nLight Air 2 Wireless Enabled DALI² DALI ECOD³ Lutron EcoSystem Digital Driver 1. NLTAIR2 can be used as a normal power sensing device for nLight Air devices and luminaires with EM emergency options. It is not available with NODIM. NLTAIR2 with DCT fixtures cannot be less than 4'. 2. DALI is only available with DARK. DALI is not available with sensors. 3. ECOD is only available with MINI. It is not available with E10WLCP & sensors. It is only available with 300LMF, 600LMF, 1000LMF or 1500LMF.	(blank) No sensors or Zones NS_ Primary Zone with No Sensor (Specify length in feet) ADC¹ Daylight Dimming Sensor PDT¹ Dual Technology Occupancy Sensor, PIR and Microphonics Sensor APIR² Passive Infrared Occupancy and Daylight Dimming Sensor APDT² Dual Technology Occupancy and Daylight Dimming Sensor Sensors are only available with FLL and fixtures 4' and above. Please see page 8 for more details. 1. ADC & PDT are available with ZT or NLIGHT. 2. APIR & APDT are available with ZT, NLIGHT or NLTAIR2.	(blank) No Sensors or Secondary Zone SNS_ Secondary Zone with No Sensor (Specify length in feet) SADC¹ Daylight Dimming Sensor, Secondary Zone SPDT¹ Dual Technology Occupancy Sensor, PIR and Microphonics Sensor, Secondary Zone SAPIR² Passive Infrared Occupancy and Daylight Dimming Sensor, Secondary Zone SAPDT² Dual Technology Occupancy and Daylight Dimming Sensor, Secondary Zone Sensors are only available with FLL and fixtures 4' and above. Please see page 8 for more details. 1. ADC & PDT are available with ZT or NLIGHT/ 2. APIR & APDT are available with ZT, NLIGHT or NLTAIR2.	(blank) No Tertiary Zone TNS_ Tertiary Zone (Specify length in feet)	F1/ T-Bar Ceiling with Universal Mounting Bracket F1A/ T-Bar Ceiling with Universal Mounting Bracket & Integrated J-Box F2/ Hard Ceiling

Overall Suspension	Canopy Form	Canopy Color	Cord Color	Options
36A 36" Adjustable 72A 72" Adjustable 144A 144" Adjustable	RDCY Round Canopy SQCY Square Canopy	BLKCY Black Canopy WHTCY White Canopy SLVCY Silver Canopy	WCRD White Cord BCRD Black Cord CAT5 cord, when included, will be white.	(blank) No Options MCS Matching Support Canopy PIF¹ Feed Cord Installed BAA Manufactured in US 1. Cord length will match overall suspension length specified.

Note: Unit length and lumen outputs may affect available options.



Catalog Information:

S4PD-LLP-[LENGTH]-90CRI-35K-1000LMF-SCT-MIN1-FLL-MVOLT-WHTT-ZT-F2/144A-RDCY-WHTCY-WCRD

Date: 02/22/2023
Fixture Type:

B5B

PHOTOMETRICS



Test Report: ISF 222300P181
IES LM79-08
S4PD U4 80CRI 35K 1000LMF
Lumens: 3889.8
Wattage: 31.85
Efficacy: 122.13



Test Report: ISF 23344P181
IES LM79-08
S4PD U4 80CRI 35K 1000LMF DBW
Lumens: 3103.9
Wattage: 31.85
Efficacy: 97.45

EXPECTED LIFE: L90 @ 60,000 HOURS
CALCULATED LIFE: L80 @ 120,000 HOURS

CCT SCALING CHART

CCT	CRI	MULTIPLIER
27K	80CRI	0.94
30K	80CRI	0.97
35K	80CRI	1.00
40K	80CRI	1.02
50K	80CRI	1.04
27K	90CRI	0.79
30K	90CRI	0.81
35K	90CRI	0.83
40K	90CRI	0.84
50K	90CRI	0.88

Lumen scaling charts can be used to approximate the lumen values at different Kelvin temperatures, color rendering indices, optics or sheilding.
Example: Find base lumen value x multiplier value = new lumen value

OPTICAL SCALING CHARTS

DOWNLIGHT	
DISTRIBUTIONS	MULTIPLIER
WW	0.80
WG	0.85
DBW	0.80

**Base fixture with Lambertian distribution and flush lens*

UGR CHART

COMING SOON		
--------------------	--	--

UGR varies based on luminaire options and is affected by application dependent parameters. Numbers depicted here are considered "Luminaire-UGR" and/or "Point-UGR" values. To determine a more precise maximum UGR value ("Application-UGR"), a full lighting design layout should be completed with the selected luminaire configuration for each application.

LINEAR PLAN

Mark Lighting offers the ability to provide a continuous run plan to suit your requirements by optionally offering three different methods of configuration.

LLP- Linear Longest Possible

In this configuration, the longest length available is optimized, resulting in the fewest segments and mounting locations. Example: 20 FT run would have 2, 8 FT segments and 1, 4 FT segment at the end of the run.

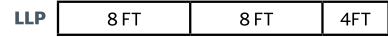

LCB- Linear Center Balanced:

This configuration incorporates the longest center segment(s) along with any additional lengths required to fill the run length, added to the run ends. Example: 16 FT run would have 2, 4 FT segments (one at each end) and 1, 8 FT segment in the center.



LSL- Linear Same Length:

In this configuration, each segment is the same length and is standardized based on the longest length available and is the only option provided. Because it is dependent on one segment length and there are mathematical limitations on what overall row lengths can be achieved. Example: 20 FT row would be achieved with 5, 4 FT long segments equaling 20 FT (nominal).

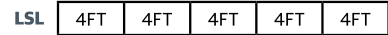

Total Run Length

This system is not modular. Runs longer than 8 FT will be automatically configured with left, intermediate and right sections, based on how you specify the TOTAL RUN LENGTH and MAXIMUM SECTION LENGTH parameters in the ordering information. Always order the total run length, not the individual sections.

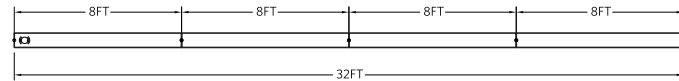

Example: This run must be ordered as 1pc "S4PD LLP 32FT MSL8..."



Example: If you order as 4pcs "S4PD LLP 8FT MSL8... you will receive these INDIVIDUAL sections that cannot be joined together

Maximum Section Length

The run will be broken out using as many sections at the chosen maximum section length as possible. Shorter sections will then complete the desired run length.

Examples:

S4PD LLP 21FT MSL5... = 5FT / 4FT / 4FT / 4FT / 4FT

S4PD LLP 21FT MSL6... = 6FT / 6FT / 5FT / 4FT

S4PD LLP 21FT MSL7... = 7FT / 7FT / 7FT

S4PD LLP 21FT MSL8... = 8FT / 8FT / 5FT

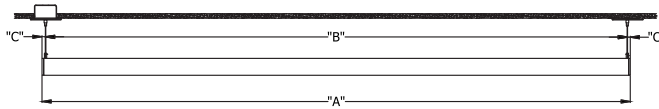

ORDERED LENGTH	INDIVIDUAL FIXTURES			APPROX. WEIGHT
	"A" O.A.L.	"B" O.C.	"C" FROM END	
2FT	2'- 0 9/16"	1'- 11 13/16"	3/8"	2
3FT	3'- 0 9/16"	2'- 11 13/16"	3/8"	3
4FT	4'- 0 9/16"	3'- 11 13/16"	3/8"	4
5FT	5'- 0 9/16"	4'- 11 13/16"	3/8"	5
6FT	6'- 0 9/16"	5'- 11 13/16"	3/8"	6
7FT	7'- 0 9/16"	6'- 11 13/16"	3/8"	7
8FT	8'- 0 9/16"	7'- 11 13/16"	3/8"	8

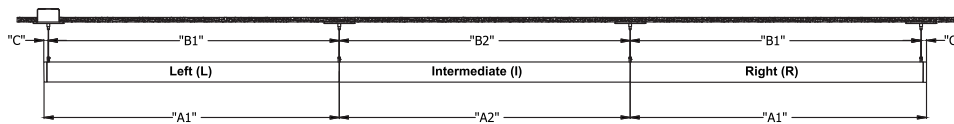

ORDERED LENGTH	RUN LAYOUT					APPROX. WEIGHT
	"A1" O.A.L.	"A2" O.A.L.	"B1" O.C.	"B2" O.C.	"C" FROM END	
4FT	4'- 0 1/4"	4'-0"	3'- 11 15/16"	4'-0"	3/8"	4
5FT	5'- 0 1/4"	5'-0"	4'- 11 15/16"	5'-0"	3/8"	5
6FT	6'- 0 1/4"	6'-0"	5'- 11 15/16"	6'-0"	3/8"	6
7FT	7'- 0 1/4"	7'-0"	6'- 11 15/16"	7'-0"	3/8"	7
8FT	8'- 0 1/4"	8'-0"	7'- 11 15/16"	8'-0"	3/8"	8

SHIELDING, OPTICS & CONNECTORS

Direct Shielding

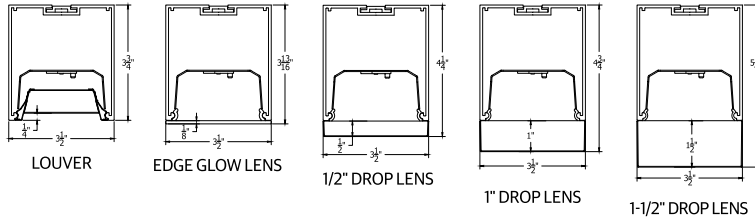

Direct Optics

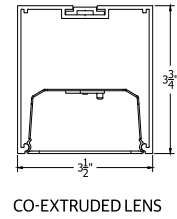

Optical Film with
Co-Extruded Lens
(Batwing (DBW),
Wall Graze (WG),
Wall Wash (WW))

Run Patterns, Corners and Junction

Patterns can be configured in 1' increments with illuminated L, T & X connectors with standard 2' corner. L connectors are available in 40-160 degrees in 1 degree increments. T & X connectors available in 90 degrees. For custom angles, corner or junction lengths, consult factory. See separate pattern spec sheet for more details.

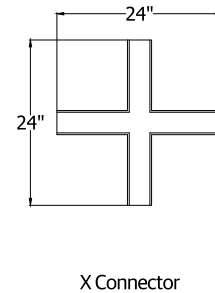
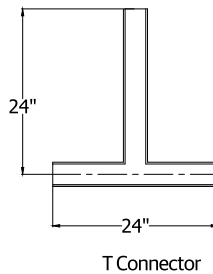
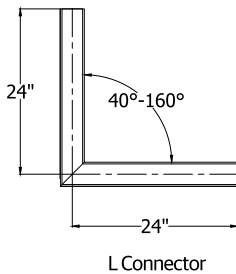

MOST COMMON MOUNTING TYPES AND OPTIONS Options available for this specific luminaire are checked in the boxes below.

Mounting Type

- F1/** For use with most T-Bar and screw slot grid ceilings. Designed for on-grid and off-grid applications. (J-box by others)
- F1A/** For use with most T-Bar grid ceilings. Designed for on-grid applications. Comes complete with J-box with built-in cutout to go over grid
- F2/** For use with recessed or surface mount horizontal J-box applications. (J-box by others)

Mounting Options

- MCS** MCS canopy supplies 5" canopy to match feed point canopy size. Matching canopy at support for aesthetics.
- PIF** Feed cord installed in fixture.

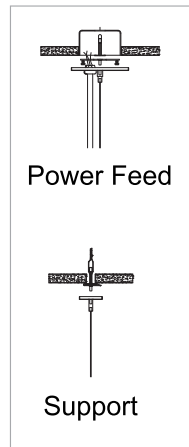

Mounting with Feed (SPSWIFK)

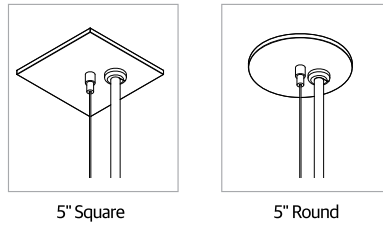

Mounting with Dual Feed (SPSW2FK)

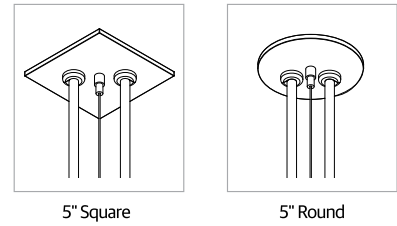

Mounting Support (SPSWSK)

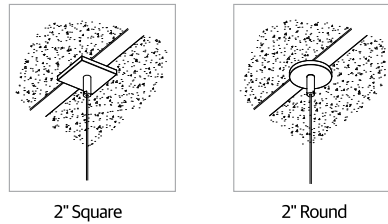

MCS Option

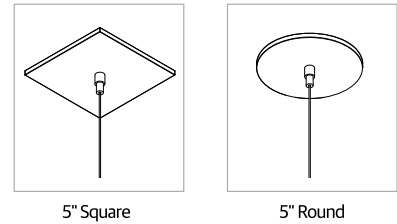

INTELLIGENT LUMINAIRE TECHNOLOGY GUIDE

Choose nomenclature from these columns				
Driver Configurations	Minimum Dimming Level	Control Input	Dimming Range	Notes
	NO DIM	(blank)	-	No 0-10V leads from the driver.
	MINIO	ZT	100 to 10%	
	MIN1	ZT	100 to 1%	
	MIN1	NLIGHT	100 to 1%	
	MIN1	ECOD	100 to 1%	Lutron Hi-lume 1% EcoSystem LED Driver with Soft-on, Fade-to-Black (model LDE1)
	DARK	ZT	100 to 0.1%	
	DARK	NLIGHT	100 to 0.1%	
	DARK	DALI	100 to 0.1%	*Compatible with DALI. Formerly (EDB & EDAB) nomenclature.* Logarithmic dimming

Choose nomenclature from these columns				
Control / Sensor Configurations	Control Input	Sensor	Sensor	Notes
	ZT	ADC	MSD ADC	Automatic dimming control integral photocell.
	ZT	PDT	MSD PDT 7	Dual technology integral occupancy sensor.
	ZT	APIR	MSD 7 ADC	PIR integral occupancy sensor with automatic dimming control photocell.
	ZT	APDT	MSD PDT 7 ADC	Dual technology integral occupancy sensor with automatic dimming control photocell.
	NLIGHT	(blank)	nIO EZ PH	nLight enabled only. No onboard sensor.
	NLIGHT	ADC	nIO EZ PH + nES ADCX	Automatic dimming control integral photocell. nLight enabled.
	NLIGHT	PDT	nIO EZ PH + nES PDT 7	360° Dual technology integral occupancy sensor. nLight enabled.
	NLIGHT	APIR	nIO EZ PH + nES 7 ADCX	360° PIR integral occupancy sensor with automatic dimming control photocell. nLight enabled.
	NLIGHT	APDT	nIO EZ PH + nES PDT 7 ADCX	360° Dual technology integral occupancy sensor with automatic dimming control photocell. nLight enabled.
	NLTAIR2	(blank)	RIO EZDL EXT900 ACWH 90D G2	nLight AIR enabled only. No onboard sensor.
	NLTAIR2	APIR	RES7 EXT900 ACWH 90D G2	PIR integral occupancy sensor with automatic dimming control photocell. nLight AIR enabled.
	NLTAIR2	APDT	RES7 PDT EXT900 ACWH 90D G2	Dual technology integral occupancy sensor with automatic dimming control photocell. nLight AIR enabled.

For more information, please consult our technical guides for [nLight](#) or [nLight Air](#).

UL924 Sequence of Operation

The below information applies to all nLight AIR devices with an EM option.

- EM devices will remain at their high-end trim and ignore wireless lighting control commands, unless a normal-power-sensed (NPS) broadcast is received at least every 8 seconds.
- Using the **CLAIRITY+** mobile app, EM devices must be associated with a group that includes a normal power sensing device to receive NPS broadcasts.
- Only non-emergency rPP20, rLSXR, rSBOR, rSDGR, and nLight AIR luminaires with version 3.4 or later firmware can provide normal power sensing for EM devices. See specification sheets for control devices and luminaires for more information on options that support normal power sensing.

nLight® Wired Control Accessories
Order as separate catalog number

Wall Switches	Model Number
On/Off single pole	nPODMA (color)
On/Off two pole	nPODMA 2P (color)
On/Off single pole, dimming	nPODMA DX (color)
On/Off two pole, dimming	nPODMA 2P DX (color)
On/Off, two level	nPODMA 2L (color)
Graphic touchscreen	nPOD TOUCH (color)

For more information see [nPOD](#) and [nPOD TOUCH](#) spec sheets

nLight AIR® Control Accessories
Order as separate catalog number

Wall Switches	Model Number
On/Off single pole	rPODBA (color)
On/Off two pole	rPODBA 2P (color)
On/Off single pole, dimming	rPODBA DX (color)
On/Off two pole, dimming	rPODBA 2P DX (color)
On/Off, 4 scene control	rPODBA 4S (color)

For more information see [rPOD](#) spec sheets



Catalog Information:

S4PD-LLP-[LENGTH]-90CRI-35K-1000LMF-SCT-MIN1-FLL-MVOLT-WHTT-ZT-F2/144A-RDCY-WHTCY-WCRD

Date:02/22/2023
Fixture Type:

B5B

INTEGRATED SENSOR LAYOUT

For runs longer than 8FT:
ALWAYS order the run by the TOTAL RUN LENGTH. Ordering the sections individually will not provide the correct joining hardware to allow connection in the field.

CORRECT:

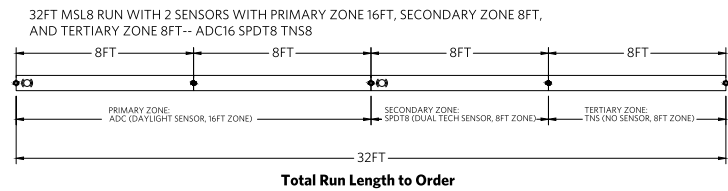
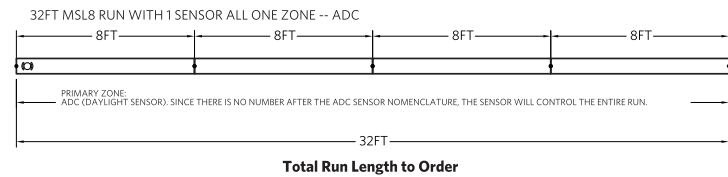
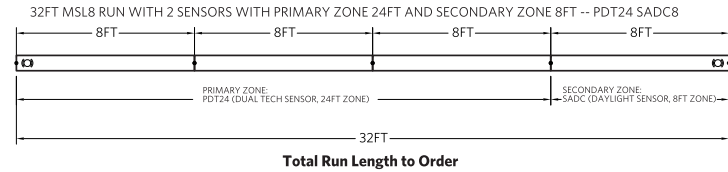

INCORRECT:

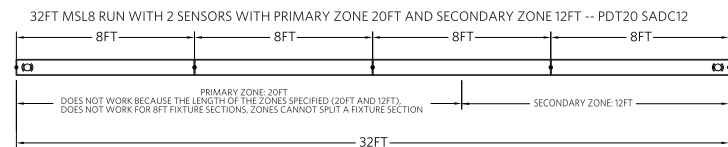
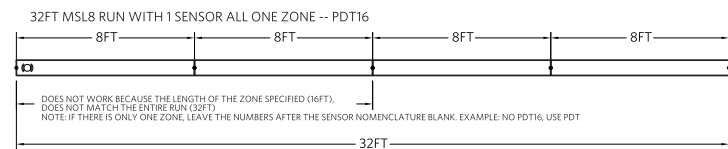

Notes:

- Only one sensor per zone
- At the most, the entire run can only have 2 sensors (thus 2 sensors zones at the most)
- Sensor zone can not split fixture sections
- No overlapping zones

OCCUPANCY DETECTION COVERAGE

At the 7.5 ft (2.9 m) hanging height of a typical pendant mount fixture the sensor provides 10 ft (3.05 m) radial detection of small motion. At a 9 ft (2.74 m) hanging height the radius is 12 ft (3.66 m) for small motion.

Adequate for walking motion detection from mounting heights between 7.5 ft (2.29 m) and 20 ft (6.10 m).

Initial detection will occur earlier when walking across sensor's field of view than when walking directly at sensor.

Initial detection of walking motion into long coverage segment will occur at distances of 2x the mounting height up to 15 ft (4.57 m) and 1.75x up to 20 ft (6.10 m). Lens assembly rotates 15° to enable adjustment in order to line up long segments.

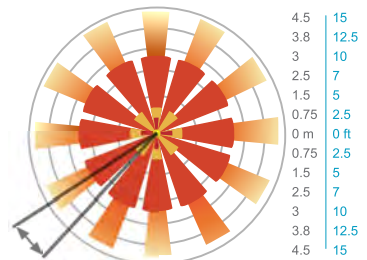

Lens rotates 15° to enable adjustment

Integrated Controls

Optional nLight® integrated controls make Slot LED luminaires addressable- allowing them to digitally communicate with other nLight enabled controls such as dimmers, switches, occupancy sensors and photocontrols. Simply connect all the nLight enabled control devices using standard CAT5 Cabling (included).

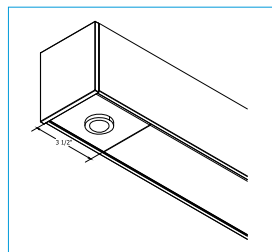

Occupancy Sensor and/or Photocell

nLight Air Wireless Antenna Location

Note: Antenna will be shipped separately and will need to be attached to the coax connector.

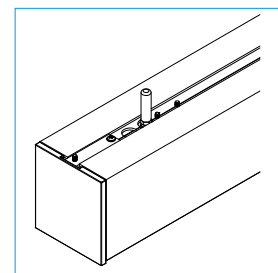

EMERGENCY OPTIONS

Emergency Battery Packs

The PS1055LCP battery is integral to the fixture and comes standard with a remote test switch and self-diagnostics. Only direct light portion operated by emergency, as indicated below.

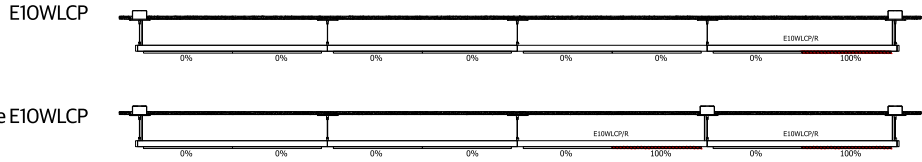

Emergency Circuits

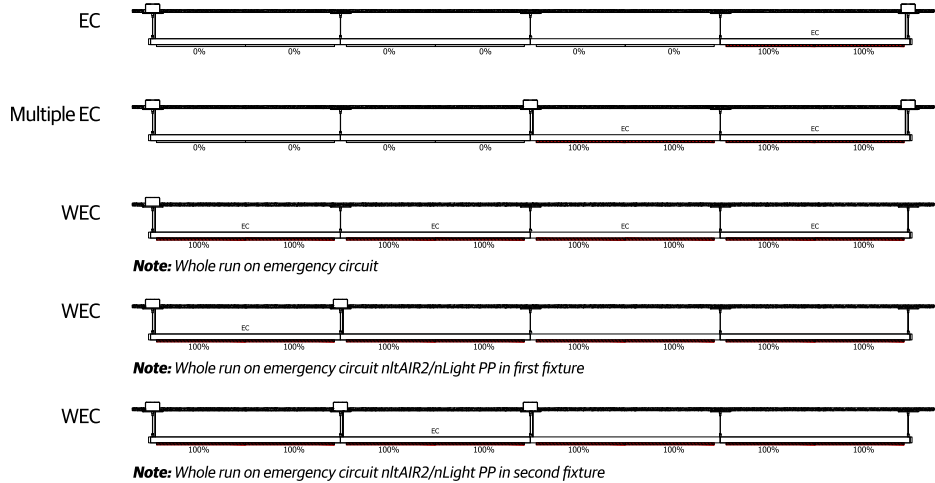

How to Estimate Delivered Lumens in Emergency Mode
Use the formula below to estimate the delivered lumens in emergency mode
Delivered Lumens = 1.25 x P x LPW
P = 10W for PS1055LCP
LPW = Lumen per watt rating of the luminaire This information is available on page 1 of this spec sheet or appropriate IES file.

Section Length	E10WLCP	EC
U2	None	Entire unit
U3	None	Entire unit
U4	Entire unit	Entire unit
U5	Last 3'	Entire unit
U6	Last 3'	Entire unit
U7	Last 4'	Entire unit
U8	Last 4'	Entire unit

Remote GTD Mounting Option

Recessed in ceiling. Consult factory for other ceiling types or canopy options. 6 foot flexible conduit included, GTD option should be mounted within 6 feet of junction box above fixture.

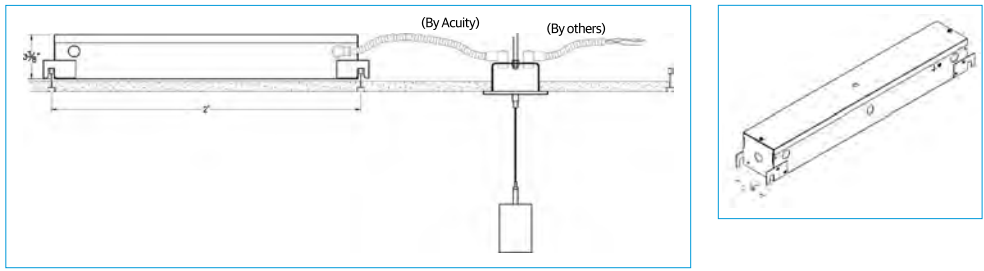

Accessible Ceiling

SPECIFICATIONS

Housing

One-piece extruded aluminum housing

Finish

Standard colors for fixtures and end caps are polyester powder coated white, black, or silver with satin sheen. Consult factory for custom colors and RAL color options.

Optics (Distribution)

Wall Wash (WW), Wall Graze (WG), and Direct Batwing (DBW) incorporate co-extruded lenses and films.

Lenses/Shielding

Direct: Extruded acrylic lens, (FLL, CLL). Edge Glow lens, (EGLD), Aluminum baffle with either a powder coat finish (LVRR) or aluminum finish (LVRRRA). Extruded acrylic drop lens (DRPO5, DRP1, DRP15).

LED Components

Multiple lumen packages available with 2700K, 3000K, 3500K, 4000K and 5000K CCT. The Acuity Brands circuit boards for the linear LED components use a precise binning algorithm which creates a consistent color temperature from board to board. The color variation of no greater than a 2.5 Step MacAdam (2.55DECM) along the black body locus from board to board.

Electrical

Long-life LEDs, coupled with high-efficiency drivers, provide superior quantity and quality of illumination for extended service life. 90% LED lumen maintenance at 60,000 hours (L90/60,000).

Circuits

Single and dual switching options available. Dual switching offered with shared neutral.

Controls System Networking Options

Optional integrated nLight® controls make each fixture addressable - allowing it to digitally communicate with other nLight enabled controls such as dimmers, switches, occupancy sensors, and photocontrols. Connection to nLight is simple. It can be accomplished with remote nLight AIR wireless or through standard Cat-5 cabling. (cabling "by others") nLight offers unique plug-and-play convenience as devices and luminaires automatically discover each other, while nLight AIR is commissioned easily through an intuitive mobile app.

Emergency Battery (Optional)

Integral emergency battery (E10WLCP) for 90 minutes of operation. Emergency battery pack, 10W, Linear Constant Power Certified in CA Title 20 MAEDBS.

Remote generator transfer device (GTD) works in conjunction with an auxiliary generator or a central inverter system to power fixtures for safe egress lighting.

Dimming Drivers

Factory tuned constant current electronic dimming driver is standard. Flicker free dimming available down to <1%. LED drivers perform within the recommended operating areas for flicker as a function of frequency and modulation (%) IEEE Standard 1789-2015 (IEEE Recommended Practices for Modulating Current in High-Brightness LEDs for Mitigating Health Risks to Viewers), in typical operating conditions at representative dimming levels. Electrical specifications at maximum driver load: PF > 0.9 and THD <20%. Meets FCC Title 47 Class A or Class B. Other available drivers include Lutron and DALI protocol drivers. All drivers are RoHS compliant.

Environment

Suitable for damp location. Indoor use only.

Certification

CSA certified to meet U.S. and Canadian standards (UL1598 and UL8750).

Ambient Operating Temperature

-20°C (-4° F) to +25°C (+77°F).

Buy American Act

Product with the BAA option is assembled in the USA and meets the Buy America(n) government procurement requirements under FAR, DFARS and DOT regulations. Please refer to www.acuitybrands.com/buy-american for additional information.

Fixture Weight

1 lbs per foot, less packaging.

Warranty

5-year limited warranty. This is the only warranty provided and no other statements in this specification sheet create any warranty of any kind. All other express and implied warranties are disclaimed. Complete warranty terms located at: www.acuitybrands.com/support/warranty/terms-and-conditions

Note: Actual performance may differ as a result of end-user environment and application.

All values are design or typical values, measured under laboratory conditions at 25 °C.

Specifications subject to change without notice.

GyroShift 3" Cylinder

25W LED Pendant
Round

Catalog #:

Type:

Project:

Date:

Notes:

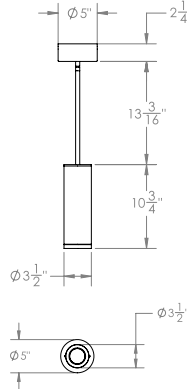

STANDARD FINISHES

<input type="checkbox"/> ABL (Aegean Blue)	<input type="checkbox"/> PNC (Painted Natural Copper)
<input type="checkbox"/> BB (Burnished Bronze)	<input type="checkbox"/> RD (Red)
<input type="checkbox"/> BK (Gloss Black)	<input type="checkbox"/> SGR (Sage Green)
<input type="checkbox"/> BLU (Blue)	<input type="checkbox"/> SND (Sand)
<input type="checkbox"/> DVG (Dove Gray)	<input type="checkbox"/> SS (Satin Silver)
<input type="checkbox"/> FLG (Flannel Gray)	<input type="checkbox"/> TBZ (Textured Bronze)
<input type="checkbox"/> GA (Galvanized)	<input type="checkbox"/> TGP (Textured Graphite)
<input type="checkbox"/> GWT (Gloss White)	<input type="checkbox"/> TNG (Tangerine)
<input type="checkbox"/> LG (Lime Green)	<input type="checkbox"/> TTL (Tahitian Teal)
<input type="checkbox"/> MB (Matte Black)	<input type="checkbox"/> WT (Semi Gloss White)
<input type="checkbox"/> MBL (Midnight Blue)	<input type="checkbox"/> YEL (Yellow)
<input type="checkbox"/> PNA (Painted Natural Aluminum)	

Electrical Data

CCT	CRI	Wattage	Delivered Lumens	Efficacy
2700K	90 CRI	25W	1550 lm	62 lpw
3000K	90 CRI	25W	1640 lm	65 lpw
3500K	90 CRI	25W	1725 lm	69 lpw
4000K	90 CRI	25W	1795 lm	72 lpw
Warm Dim	-	10W	608 lm	61 lpw

Lumens will vary depending on CCT, optic & lens option

Specifications

- Field Replaceable LED Light Engine**
- 25W LED with 2 SDCM binning
 - 2700K, 3000K, 3500K and 4000K at 90 CRI
 - 10°, 30° and 50° and optics included
 - 45° adjustability with 360° aiming

Finishes

Available in many colors with optional coastal coating to protect finish in coastal environments

Listing / Warranty

- Five (5) year limited warranty
- UL listed to US and Canadian standards for damp location

Field Replaceable Dimming Driver

- Multiple dimming drivers available
- Power factor > 0.9, 50/60Hz

Mounting

- 4' of stem included; (1) 6", (2) 12" & (1) 18" (includes couplers)
Contact the factory for custom sloped ceiling projects
- 10' field adjustable cord available, must specify
- 5" x 2-1/4" canopy included with standard universal dim driver
(7-1/8" x 2-1/4" round included with Lutron and eldoLED drivers)



Order Matrix

GyroShift 3" Pendant Cylinder (Example: LP3-SFT-10S2710ABL-NLNL-ST-0)

Series	Wattage	Driver	CCT / CRI	Optic	Finishes	Coastal Coating Option	Media 1	Media 2	Option	Rev	Canopy
LP3-SFT (Round)	<input type="checkbox"/> -10 (10W)	<input type="checkbox"/> S ² (ERP, Universal Dim, Triac/ELV/0-10V 1% 120-277V) <input type="checkbox"/> L1 ¹ (Lutron Hi-Lume [®] 2-Wire 1% 120V) Fade-to-Black 1% 120-277V) <input type="checkbox"/> L3 ¹ (Lutron Hi-Lume [®] 2-Wire 1% 120V) Fade-to-Black 1% 120-277V) <input type="checkbox"/> EL1 ¹ (eldoLED DALI 1% 120-277V) <input type="checkbox"/> EL2 ¹ (eldoLED 0-10V 1% 120-277V) <input type="checkbox"/> DMX ¹ (DMX 1% 120-277V)	<input type="checkbox"/> 27 (2700K/90 CRI)	<input type="checkbox"/> 10 <input type="checkbox"/> 30 <input type="checkbox"/> 35 <input type="checkbox"/> 40 <input type="checkbox"/> WD* (1850-3000K)	<input type="checkbox"/> 10 <input type="checkbox"/> 30 <input type="checkbox"/> 50	<input type="checkbox"/> (blank) (No coating) <input type="checkbox"/> -C (Coating)	<input type="checkbox"/> -NL (No Lens) <input type="checkbox"/> -CL (Clear Lens) <input type="checkbox"/> -FR (Frosted Lens) <input type="checkbox"/> -MP (Solite Lens) <input type="checkbox"/> -LS (Linear Spread) <input type="checkbox"/> -HEX* (Hex Louver) <input type="checkbox"/> -WW* (Wall Wash)	<input type="checkbox"/> NL <input type="checkbox"/> CL <input type="checkbox"/> FR <input type="checkbox"/> MP <input type="checkbox"/> LS	<input type="checkbox"/> -ST ⁴ 4' Stem <input type="checkbox"/> -BC 10' Black Cord <input type="checkbox"/> -WC 10' White Cord <input type="checkbox"/> -LV ³ 10' Low Voltage Aircraft Cable	-0	<input type="checkbox"/> (blank) (standard canopy) <input type="checkbox"/> -CC1 ⁵ (Conduit 3-1/4" canopy) <input type="checkbox"/> -CC2 (Conduit 3-7/8" canopy)
	<input type="checkbox"/> -15 (15W)		<input type="checkbox"/> 30 (3000K/90 CRI)								
	<input type="checkbox"/> -20 (20W)		<input type="checkbox"/> 35 (3500K/90 CRI)								
	<input type="checkbox"/> -25 (25W)		<input type="checkbox"/> 40 (4000K/90 CRI)								

- Includes larger canopy
- Forward and reverse dimming at 120V only
- Damp Location Rated
- Stem kit includes: (1) x 6", (2) x 12", (1) x 18"
- CC1 and CC2 only for S driver option

Media

<input type="checkbox"/> S3-LENS-CL-0 (Clear Lens)	<input type="checkbox"/> S3-LENS-LS-0 (Linear Spread)
<input type="checkbox"/> S3-LENS-FR-0 (Frosted Lens)	<input type="checkbox"/> S3-LENS-HEX-0* (Hex Louver)
<input type="checkbox"/> S3-LENS-MP-0 (Solite Lens)	<input type="checkbox"/> S3-LENS-WW-0* (Wall Wash)

*Note: Can only fit 1 media if HEX or WW is selected

Emergency

<input type="checkbox"/> EM-1000 (25W LED Remote Inverter)
<input type="checkbox"/> EM-1002 (10W LED Remote Emergency Driver)

Spec:00254 Revised 07/13/2022

Patent: www.cslighting.com/patents

14508 Nelson Ave. City of Industry, CA 91744 • tel: 626.336.4511 • fax: 626.330.4266 • www.cslighting.com
©2021 Creative Systems Lighting, A Division of Troy-CSL Lighting, Inc. All rights reserved. Subject to change without notice.



Catalog
Information:

LP3-SFT-20-S-35-50-MB-CL-NL-BC-0

Date:02/22/2023

Fixture Type:

B17

Page: 1 of 1

GyroShift 3" Cylinder

25W LED Pendant
Round

Catalog #:

Type:

Project:

Date:

Notes:

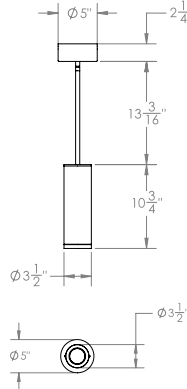

STANDARD FINISHES

<input type="checkbox"/> ABL (Aegean Blue)	<input type="checkbox"/> PNC (Painted Natural Copper)
<input type="checkbox"/> BB (Burnished Bronze)	<input type="checkbox"/> RD (Red)
<input type="checkbox"/> BK (Gloss Black)	<input type="checkbox"/> SGR (Sage Green)
<input type="checkbox"/> BLU (Blue)	<input type="checkbox"/> SND (Sand)
<input type="checkbox"/> DVG (Dove Gray)	<input type="checkbox"/> SS (Satin Silver)
<input type="checkbox"/> FLG (Flannel Gray)	<input type="checkbox"/> TBZ (Textured Bronze)
<input type="checkbox"/> GA (Galvanized)	<input type="checkbox"/> TGP (Textured Graphite)
<input type="checkbox"/> GWT (Gloss White)	<input type="checkbox"/> TNG (Tangerine)
<input type="checkbox"/> LG (Lime Green)	<input type="checkbox"/> TTL (Tahitian Teal)
<input type="checkbox"/> MB (Matte Black)	<input type="checkbox"/> WT (Semi Gloss White)
<input type="checkbox"/> MBL (Midnight Blue)	<input type="checkbox"/> YEL (Yellow)
<input type="checkbox"/> PNA (Painted Natural Aluminum)	

Electrical Data

CCT	CRI	Wattage	Delivered Lumens	Efficacy
2700K	90 CRI	25W	1550 lm	62 lpw
3000K	90 CRI	25W	1640 lm	65 lpw
3500K	90 CRI	25W	1725 lm	69 lpw
4000K	90 CRI	25W	1795 lm	72 lpw
Warm Dim	-	10W	608 lm	61 lpw

Lumens will vary depending on CCT, optic & lens option

Specifications

- Field Replaceable LED Light Engine**
- 25W LED with 2 SDCM binning
 - 2700K, 3000K, 3500K and 4000K at 90 CRI
 - 10°, 30° and 50° and optics included
 - 45° adjustability with 360° aiming

- Finishes**
- Available in many colors with optional coastal coating to protect finish in coastal environments

Listing / Warranty

- Five (5) year limited warranty
- UL listed to US and Canadian standards for damp location

Field Replaceable Dimming Driver

- Multiple dimming drivers available
- Power factor > 0.9, 50/60Hz

Mounting

- 4' of stem included; (1) 6", (2) 12" & (1) 18" (includes couplers)
Contact the factory for custom sloped ceiling projects
- 10' field adjustable cord available, must specify
- 5" x 2-1/4" canopy included with standard universal dim driver
(7-1/8" x 2-1/4" round included with Lutron and eldoLED drivers)



Order Matrix

GyroShift 3" Pendant Cylinder (Example: LP3-SFT-10S2710ABL-NLNL-ST-0)

Series	Wattage	Driver	CCT / CRI	Optic	Finishes	Coastal Coating Option	Media 1	Media 2	Option	Rev	Canopy
LP3-SFT (Round)	<input type="checkbox"/> -10 (10W)	<input type="checkbox"/> S ² (ERP, Universal Dim, Triac/ELV/0-10V 1% 120-277V) <input type="checkbox"/> L1 ¹ (Lutron Hi-Lume [®] 2-Wire 1% 120V) <input type="checkbox"/> L3 ¹ (Lutron Hi-Lume [®] Fade-to-Black 1% 120-277V) <input type="checkbox"/> EL1 ¹ (eldoLED DALI 1% 120-277V) <input type="checkbox"/> EL2 ¹ (eldoLED 0-10V 1% 120-277V) <input type="checkbox"/> DMX ¹ (DMX 1% 120-277V)	<input type="checkbox"/> 27 (2700K/90 CRI)	<input type="checkbox"/> 10 <input type="checkbox"/> 30 <input type="checkbox"/> 35 <input type="checkbox"/> 40 <input type="checkbox"/> WD* (1850-3000K)	<input type="checkbox"/> ABL <input type="checkbox"/> BB <input type="checkbox"/> BK <input type="checkbox"/> BLU <input type="checkbox"/> DVG <input type="checkbox"/> FLG <input type="checkbox"/> GA <input type="checkbox"/> GWT <input type="checkbox"/> LG <input type="checkbox"/> MB <input type="checkbox"/> MBL <input type="checkbox"/> PNA <input type="checkbox"/> PNC <input type="checkbox"/> RD <input type="checkbox"/> SGR <input type="checkbox"/> SND <input type="checkbox"/> SS <input type="checkbox"/> TBZ <input type="checkbox"/> TGP <input type="checkbox"/> TNG <input type="checkbox"/> TTL <input type="checkbox"/> WT <input type="checkbox"/> YEL	<input type="checkbox"/> (blank) (No coating)	<input type="checkbox"/> -NL (No Lens) <input type="checkbox"/> -CL (Clear Lens) <input type="checkbox"/> -FR (Frosted Lens) <input type="checkbox"/> -MP (Solite Lens) <input type="checkbox"/> -LS (Linear Spread) <input type="checkbox"/> -HEX* (Hex Louver) <input type="checkbox"/> -WW* (Wall Wash)	<input type="checkbox"/> NL <input type="checkbox"/> CL <input type="checkbox"/> FR <input type="checkbox"/> MP <input type="checkbox"/> LS	<input type="checkbox"/> -ST ⁴ 4' Stem <input type="checkbox"/> -BC 10' Black Cord <input type="checkbox"/> -WC 10' White Cord <input type="checkbox"/> -LV ³ 10' Low Voltage Aircraft Cable	-0	<input type="checkbox"/> (blank) (standard canopy) <input type="checkbox"/> -CC1 ⁵ (Conduit 3-1/4" canopy) <input type="checkbox"/> -CC2 (Conduit 3-7/8" canopy)
	<input type="checkbox"/> -15 (15W)		<input type="checkbox"/> 30 (3000K/90 CRI)			<input type="checkbox"/> -C (Coating)					
	<input type="checkbox"/> -20 (20W)		<input type="checkbox"/> 35 (3500K/90 CRI)								
	<input type="checkbox"/> -25 (25W)		<input type="checkbox"/> 40 (4000K/90 CRI) <input type="checkbox"/> WD* (1850-3000K)								

- Includes larger canopy
- Forward and reverse dimming at 120V only
- Damp location Rated
- Stem kit includes: (1) x 6", (2) x 12", (1) x 18"
- CC1 and CC2 only for S driver option

Media

<input type="checkbox"/> S3-LENS-CL-0 (Clear Lens)	<input type="checkbox"/> S3-LENS-LS-0 (Linear Spread)
<input type="checkbox"/> S3-LENS-FR-0 (Frosted Lens)	<input type="checkbox"/> S3-LENS-HEX-0* (Hex Louver)
<input type="checkbox"/> S3-LENS-MP-0 (Solite Lens)	<input type="checkbox"/> S3-LENS-WW-0* (Wall Wash)

*Note: Can only fit 1 media if HEX or WW is selected

Emergency

<input type="checkbox"/> EM-1000 (25W LED Remote Inverter)
<input type="checkbox"/> EM-1002 (10W LED Remote Emergency Driver)

Spec:00254 Revised 07/13/2022

Patent: www.cslighting.com/patents

14508 Nelson Ave. City of Industry, CA 91744 • tel: 626.336.4511 • fax: 626.330.4266 • www.cslighting.com
©2021 Creative Systems Lighting, A Division of Troy-CSL Lighting, Inc. All rights reserved. Subject to change without notice.



Catalog
Information:

LP3-SFT-20-S-35-50-MB-CL-NL-BC-0-EM-1002

Date:02/22/2023

Fixture Type:

B17-EM

GyroShift 3" Cylinder

25W LED Pendant
Round

Catalog #:

Type:

Project:

Date:

Notes:

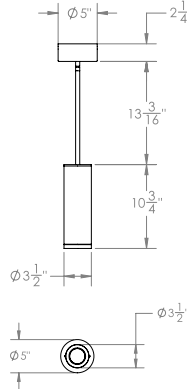

STANDARD FINISHES

- | | |
|--|--|
| <input type="checkbox"/> ABL (Aegean Blue) | <input type="checkbox"/> PNC (Painted Natural Copper) |
| <input type="checkbox"/> BB (Burnished Bronze) | <input type="checkbox"/> RD (Red) |
| <input type="checkbox"/> BK (Gloss Black) | <input type="checkbox"/> SGR (Sage Green) |
| <input type="checkbox"/> BLU (Blue) | <input type="checkbox"/> SND (Sand) |
| <input type="checkbox"/> DVG (Dove Gray) | <input type="checkbox"/> SS (Satin Silver) |
| <input type="checkbox"/> FLG (Flannel Gray) | <input type="checkbox"/> TBZ (Textured Bronze) |
| <input type="checkbox"/> GA (Galvanized) | <input type="checkbox"/> TGP (Textured Graphite) |
| <input type="checkbox"/> GWT (Gloss White) | <input type="checkbox"/> TNG (Tangerine) |
| <input type="checkbox"/> LG (Lime Green) | <input type="checkbox"/> TTL (Tahitian Teal) |
| <input type="checkbox"/> MB (Matte Black) | <input type="checkbox"/> WT (Semi Gloss White) |
| <input type="checkbox"/> MBL (Midnight Blue) | <input type="checkbox"/> YEL (Yellow) |
| <input type="checkbox"/> PNA (Painted Natural Aluminum) | |

Electrical Data

CCT	CRI	Wattage	Delivered Lumens	Efficacy
2700K	90 CRI	25W	1550 lm	62 lpw
3000K	90 CRI	25W	1640 lm	65 lpw
3500K	90 CRI	25W	1725 lm	69 lpw
4000K	90 CRI	25W	1795 lm	72 lpw
Warm Dim	-	10W	608 lm	61 lpw

Lumens will vary depending on CCT, optic & lens option

Specifications

- Field Replaceable LED Light Engine**
- 25W LED with 2 SDCM binning
 - 2700K, 3000K, 3500K and 4000K at 90 CRI
 - 10°, 30° and 50° and optics included
 - 45° adjustability with 360° aiming

Finishes

Available in many colors with optional coastal coating to protect finish in coastal environments

Listing / Warranty

- Five (5) year limited warranty
- Multiple dimming drivers available
- Power factor > 0.9, 50/60Hz
- UL listed to US and Canadian standards for damp location

Field Replaceable Dimming Driver

- Multiple dimming drivers available
- Power factor > 0.9, 50/60Hz

Mounting

- 4' of stem included; (1) 6", (2) 12" & (1) 18" (includes couplers)
Contact the factory for custom sloped ceiling projects
- 10' field adjustable cord available, must specify
- 5" x 2-1/4" canopy included with standard universal dim driver
(7-1/8" x 2-1/4" round included with Lutron and eldoLED drivers)



Order Matrix

GyroShift 3" Pendant Cylinder (Example: LP3-SFT-10S2710ABL-NLNL-ST-0)

Series	Wattage	Driver	CCT / CRI	Optic	Finishes	Coastal Coating Option	Media 1	Media 2	Option	Rev	Canopy
LP3-SFT (Round)	<input type="checkbox"/> -10 (10W)	<input type="checkbox"/> S ² (ERP, Universal Dim, Triac/ELV/0-10V 1% 120-277V) <input type="checkbox"/> L1 ¹ (Lutron Hi-Lume [®] 2-Wire 1% 120V) Fade-to-Black 1% 120-277V) <input type="checkbox"/> L3 ¹ (Lutron Hi-Lume [®] 2-Wire 1% 120V) Fade-to-Black 1% 120-277V) <input type="checkbox"/> EL1 ¹ (eldoLED DALI 1% 120-277V) <input type="checkbox"/> EL2 ¹ (eldoLED 0-10V 1% 120-277V) <input type="checkbox"/> DMX ¹ (DMX 1% 120-277V)	<input type="checkbox"/> 27 (2700K/90 CRI)	<input type="checkbox"/> 10 <input type="checkbox"/> 30 <input type="checkbox"/> 50	<input type="checkbox"/> ABL <input type="checkbox"/> BB <input type="checkbox"/> BK <input type="checkbox"/> BLU <input type="checkbox"/> DVG <input type="checkbox"/> FLG <input type="checkbox"/> GA <input type="checkbox"/> GWT <input type="checkbox"/> LG <input type="checkbox"/> MB <input type="checkbox"/> MBL <input type="checkbox"/> PNA <input type="checkbox"/> PNC <input type="checkbox"/> RD <input type="checkbox"/> SGR <input type="checkbox"/> SND <input type="checkbox"/> SS <input type="checkbox"/> TBZ <input type="checkbox"/> TGP <input type="checkbox"/> TNG <input type="checkbox"/> TTL <input type="checkbox"/> WT <input type="checkbox"/> YEL	<input type="checkbox"/> (blank) (No coating)	<input type="checkbox"/> -NL (No Lens) <input type="checkbox"/> -CL (Clear Lens) <input type="checkbox"/> -FR (Frosted Lens) <input type="checkbox"/> -MP (Solite Lens) <input type="checkbox"/> -LS (Linear Spread) <input type="checkbox"/> -HEX* (Hex Louver) <input type="checkbox"/> -WW* (Wall Wash)	<input type="checkbox"/> NL <input type="checkbox"/> CL <input type="checkbox"/> FR <input type="checkbox"/> MP <input type="checkbox"/> LS	<input type="checkbox"/> -ST ⁴ 4' Stem <input type="checkbox"/> -BC 10' Black Cord <input type="checkbox"/> -WC 10' White Cord <input type="checkbox"/> -LV ³ 10' Low Voltage Aircraft Cable	-0	<input type="checkbox"/> (blank) (standard canopy) <input type="checkbox"/> -CC1 ⁵ (Conduit 3-1/4" canopy) <input type="checkbox"/> -CC2 (Conduit 3-7/8" canopy)
	<input type="checkbox"/> -15 (15W)		<input type="checkbox"/> 30 (3000K/90 CRI)			<input type="checkbox"/> -C (Coating)					
	<input type="checkbox"/> -20 (20W)		<input type="checkbox"/> 35 (3500K/90 CRI)								
	<input type="checkbox"/> -25 (25W)		<input type="checkbox"/> 40 (4000K/90 CRI) <input type="checkbox"/> WD* (1850-3000K)								

- Includes larger canopy
- Forward and reverse dimming at 120V only
- Damp Location Rated
- Stem kit includes: (1) x 6", (2) x 12", (1) x 18"
- CC1 and CC2 only for S driver option

Media

<input type="checkbox"/> S3-LENS-CL-0 (Clear Lens)	<input type="checkbox"/> S3-LENS-LS-0 (Linear Spread)
<input type="checkbox"/> S3-LENS-FR-0 (Frosted Lens)	<input type="checkbox"/> S3-LENS-HEX-0* (Hex Louver)
<input type="checkbox"/> S3-LENS-MP-0 (Solite Lens)	<input type="checkbox"/> S3-LENS-WW-0* (Wall Wash)

*Note: Can only fit 1 media if HEX or WW is selected

Emergency

<input type="checkbox"/> EM-1000 (25W LED Remote Inverter)
<input type="checkbox"/> EM-1002 (10W LED Remote Emergency Driver)

Spec-00254 Revised 07/13/2022

Patent: www.cslighting.com/patents

14508 Nelson Ave. City of Industry, CA 91744 • tel: 626.336.4511 • fax: 626.330.4266 • www.cslighting.com
©2021 Creative Systems Lighting, A Division of Troy-CSL Lighting, Inc. All rights reserved. Subject to change without notice.



Catalog
Information:

LP3-SFT-20-S-35-30-MB-CL-BC-ST-0

Date: 02/22/2023

Fixture Type:

B17A

GyroShift 3" Cylinder

25W LED Pendant
Round

Catalog #:

Type:

Project:

Date:

Notes:

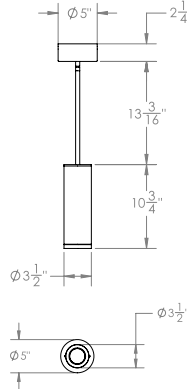

STANDARD FINISHES

- | | |
|--|--|
| <input checked="" type="checkbox"/> ABL (Aegean Blue) | <input type="checkbox"/> PNC (Painted Natural Copper) |
| <input type="checkbox"/> BB (Burnished Bronze) | <input type="checkbox"/> RD (Red) |
| <input type="checkbox"/> BK (Gloss Black) | <input type="checkbox"/> SGR (Sage Green) |
| <input type="checkbox"/> BLU (Blue) | <input type="checkbox"/> SND (Sand) |
| <input type="checkbox"/> DVG (Dove Gray) | <input type="checkbox"/> SS (Satin Silver) |
| <input type="checkbox"/> FLG (Flannel Gray) | <input type="checkbox"/> TBZ (Textured Bronze) |
| <input type="checkbox"/> GA (Galvanized) | <input type="checkbox"/> TGP (Textured Graphite) |
| <input type="checkbox"/> GWT (Gloss White) | <input type="checkbox"/> TNG (Tangerine) |
| <input type="checkbox"/> LG (Lime Green) | <input type="checkbox"/> TTL (Tahitian Teal) |
| <input checked="" type="checkbox"/> MB (Matte Black) | <input type="checkbox"/> WT (Semi Gloss White) |
| <input type="checkbox"/> MBL (Midnight Blue) | <input type="checkbox"/> YEL (Yellow) |
| <input type="checkbox"/> PNA (Painted Natural Aluminum) | |

Electrical Data

CCT	CRI	Wattage	Delivered Lumens	Efficacy
2700K	90 CRI	25W	1550 lm	62 lpw
3000K	90 CRI	25W	1640 lm	65 lpw
3500K	90 CRI	25W	1725 lm	69 lpw
4000K	90 CRI	25W	1795 lm	72 lpw
Warm Dim	-	10W	608 lm	61 lpw

Lumens will vary depending on CCT, optic & lens option

Specifications

- Field Replaceable LED Light Engine**
- 25W LED with 2 SDCM binning
 - 2700K, 3000K, 3500K and 4000K at 90 CRI
 - 10°, 30° and 50° and optics included
 - 45° adjustability with 360° aiming

Finishes

Available in many colors with optional coastal coating to protect finish in coastal environments

Listing / Warranty

- Five (5) year limited warranty
- UL listed to US and Canadian standards for damp location

Field Replaceable Dimming Driver

- Multiple dimming drivers available
- Power factor > 0.9, 50/60Hz

Mounting

- 4' of stem included; (1) 6", (2) 12" & (1) 18" (includes couplers)
Contact the factory for custom sloped ceiling projects
- 10' field adjustable cord available, must specify
- 5" x 2-1/4" canopy included with standard universal dim driver
(7-1/8" x 2-1/4" round included with Lutron and eldoLED drivers)



Order Matrix

GyroShift 3" Pendant Cylinder (Example: LP3-SFT-10S2710ABL-NLNL-ST-0)

Series	Wattage	Driver	CCT / CRI	Optic	Finishes	Coastal Coating Option	Media 1	Media 2	Option	Rev	Canopy
LP3-SFT (Round)	<input type="checkbox"/> -10 (10W)	<input type="checkbox"/> S ² (ERP, Universal Dim, Triac/ELV/0-10V 1% 120-277V) <input type="checkbox"/> L1 ¹ (Lutron Hi-Lume [®] 2-Wire 1% 120V) Fade-to-Black 1% 120-277V) <input type="checkbox"/> L3 ¹ (Lutron Hi-Lume [®] 120-277V) <input type="checkbox"/> EL1 ¹ (eldoLED DALI 1% 120-277V) <input type="checkbox"/> EL2 ¹ (eldoLED 0-10V 1% 120-277V) <input type="checkbox"/> DMX ¹ (DMX 1% 120-277V)	<input type="checkbox"/> 27 (2700K/90 CRI)	<input type="checkbox"/> 10 <input type="checkbox"/> 30 <input type="checkbox"/> 50	<input type="checkbox"/> ABL <input type="checkbox"/> BB <input type="checkbox"/> BK <input type="checkbox"/> BLU <input type="checkbox"/> DVG <input type="checkbox"/> FLG <input type="checkbox"/> GA <input type="checkbox"/> GWT <input type="checkbox"/> LG <input checked="" type="checkbox"/> MB <input type="checkbox"/> MBL <input type="checkbox"/> PNA <input type="checkbox"/> PNC <input type="checkbox"/> RD <input type="checkbox"/> SGR <input type="checkbox"/> SND <input type="checkbox"/> SS <input type="checkbox"/> TBZ <input type="checkbox"/> TGP <input type="checkbox"/> TNG <input type="checkbox"/> TTL <input type="checkbox"/> WT <input type="checkbox"/> YEL	<input type="checkbox"/> (blank) (No coating)	<input type="checkbox"/> -NL (No Lens) <input type="checkbox"/> -CL (Clear Lens) <input type="checkbox"/> -FR (Frosted Lens) <input type="checkbox"/> -MP (Solite Lens) <input type="checkbox"/> -LS (Linear Spread) <input type="checkbox"/> -HEX* (Hex Louver) <input type="checkbox"/> -WW* (Wall Wash)	<input type="checkbox"/> NL <input type="checkbox"/> CL <input type="checkbox"/> FR <input type="checkbox"/> MP <input type="checkbox"/> LS	<input type="checkbox"/> -ST ⁴ 4' Stem <input type="checkbox"/> -BC 10' Black Cord <input type="checkbox"/> -WC 10' White Cord <input type="checkbox"/> -LV ³ 10' Low Voltage Aircraft Cable	-0	<input type="checkbox"/> (blank) (standard canopy) <input type="checkbox"/> -CC1 ⁵ (Conduit 3-1/4" canopy) <input type="checkbox"/> -CC2 (Conduit 3-7/8" canopy)
	<input type="checkbox"/> -15 (15W)		<input type="checkbox"/> 30 (3000K/90 CRI)			<input type="checkbox"/> -C (Coating)					
	<input type="checkbox"/> -20 (20W)		<input type="checkbox"/> 35 (3500K/90 CRI)								
	<input type="checkbox"/> -25 (25W)		<input type="checkbox"/> 40 (4000K/90 CRI) <input type="checkbox"/> WD* (1850-3000K)								

- Includes larger canopy
- Forward and reverse dimming at 120V only
- Damp Location Rated
- Stem kit includes: (1) x 6", (2) x 12", (1) x 18"
- CC1 and CC2 only for S driver option

Media

<input type="checkbox"/> S3-LENS-CL-0 (Clear Lens)	<input type="checkbox"/> S3-LENS-LS-0 (Linear Spread)
<input type="checkbox"/> S3-LENS-FR-0 (Frosted Lens)	<input type="checkbox"/> S3-LENS-HEX-0* (Hex Louver)
<input type="checkbox"/> S3-LENS-MP-0 (Solite Lens)	<input type="checkbox"/> S3-LENS-WW-0* (Wall Wash)

*Note: Can only fit 1 media if HEX or WW is selected

Emergency

<input type="checkbox"/> EM-1000 (25W LED Remote Inverter)
<input checked="" type="checkbox"/> EM-1002 (10W LED Remote Emergency Driver)

Spec:00254 Revised 07/13/2022

Patent: www.cslighting.com/patents

14508 Nelson Ave. City of Industry, CA 91744 • tel: 626.336.4511 • fax: 626.330.4266 • www.cslighting.com
©2021 Creative Systems Lighting, A Division of Troy-CSL Lighting, Inc. All rights reserved. Subject to change without notice.



Catalog
Information:

LP3-SFT-20-S-35-30-MB-CL-NL-BC-0-EM-1002

Date:02/22/2023

Fixture Type:

B17A-EM

GyroShift 3" Cylinder

25W LED Pendant
Round

Catalog #:

Type:

Project:

Date:

Notes:

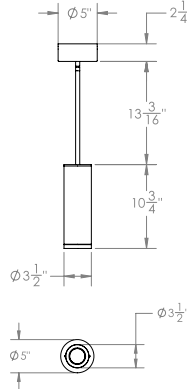

STANDARD FINISHES

- | | |
|--|--|
| <input type="checkbox"/> ABL (Aegean Blue) | <input type="checkbox"/> PNC (Painted Natural Copper) |
| <input type="checkbox"/> BB (Burnished Bronze) | <input type="checkbox"/> RD (Red) |
| <input type="checkbox"/> BK (Gloss Black) | <input type="checkbox"/> SGR (Sage Green) |
| <input type="checkbox"/> BLU (Blue) | <input type="checkbox"/> SND (Sand) |
| <input type="checkbox"/> DVG (Dove Gray) | <input type="checkbox"/> SS (Satin Silver) |
| <input type="checkbox"/> FLG (Flannel Gray) | <input type="checkbox"/> TBZ (Textured Bronze) |
| <input type="checkbox"/> GA (Galvanized) | <input type="checkbox"/> TGP (Textured Graphite) |
| <input type="checkbox"/> GWT (Gloss White) | <input type="checkbox"/> TNG (Tangerine) |
| <input type="checkbox"/> LG (Lime Green) | <input type="checkbox"/> TTL (Tahitian Teal) |
| <input checked="" type="checkbox"/> MB (Matte Black) | <input type="checkbox"/> WT (Semi Gloss White) |
| <input type="checkbox"/> MBL (Midnight Blue) | <input type="checkbox"/> YEL (Yellow) |
| <input type="checkbox"/> PNA (Painted Natural Aluminum) | |

Electrical Data

CCT	CRI	Wattage	Delivered Lumens	Efficacy
2700K	90 CRI	25W	1550 lm	62 lpw
3000K	90 CRI	25W	1640 lm	65 lpw
3500K	90 CRI	25W	1725 lm	69 lpw
4000K	90 CRI	25W	1795 lm	72 lpw
Warm Dim	-	10W	608 lm	61 lpw

Lumens will vary depending on CCT, optic & lens option

Specifications

Field Replaceable LED Light Engine

- 25W LED with 2 SDCM binning
- 2700K, 3000K, 3500K and 4000K at 90 CRI
- 10°, 30° and 50° and optics included
- 45° adjustability with 360° aiming

Finishes

Available in many colors with optional coastal coating to protect finish in coastal environments

Listing / Warranty

- Five (5) year limited warranty
- UL listed to US and Canadian standards for damp location

Field Replaceable Dimming Driver

- Multiple dimming drivers available
- Power factor > 0.9, 50/60Hz

Mounting

- 4' of stem included; (1) 6", (2) 12" & (1) 18" (includes couplers)
Contact the factory for custom sloped ceiling projects
- 10' field adjustable cord available, must specify
- 5" x 2-1/4" canopy included with standard universal dim driver
(7-1/8" x 2-1/4" round included with Lutron and eldoLED drivers)



Order Matrix

GyroShift 3" Pendant Cylinder (Example: LP3-SFT-10S2710ABL-NLNL-ST-0)

Series	Wattage	Driver	CCT / CRI	Optic	Finishes	Coastal Coating Option	Media 1	Media 2	Option	Rev	Canopy
LP3-SFT (Round)	<input type="checkbox"/> -10 (10W)	<input type="checkbox"/> S ² (ERP, Universal Dim, Triac/ELV/0-10V 1% 120-277V) <input type="checkbox"/> L1 ¹ (Lutron Hi-Lume [®] 2-Wire 1% 120V) <input type="checkbox"/> L3 ¹ (Lutron Hi-Lume [®] Fade-to-Black 1% 120-277V) <input type="checkbox"/> EL1 ¹ (eldoLED DALI 1% 120-277V) <input type="checkbox"/> EL2 ¹ (eldoLED 0-10V 1% 120-277V) <input type="checkbox"/> DMX ¹ (DMX 1% 120-277V)	<input type="checkbox"/> 27 (2700K/90 CRI)	<input type="checkbox"/> 10 <input type="checkbox"/> 30 <input type="checkbox"/> 35 <input type="checkbox"/> 40 <input type="checkbox"/> WD* (1850-3000K)	<input type="checkbox"/> 10 <input type="checkbox"/> 30 <input type="checkbox"/> 50	<input type="checkbox"/> (blank) (No coating) <input type="checkbox"/> -C (Coating)	<input type="checkbox"/> -NL (No Lens) <input type="checkbox"/> -CL (Clear Lens) <input type="checkbox"/> -FR (Frosted Lens) <input type="checkbox"/> -MP (Solite Lens) <input type="checkbox"/> -LS (Linear Spread) <input type="checkbox"/> -HEX* (Hex Louver) <input type="checkbox"/> -WW* (Wall Wash)	<input type="checkbox"/> NL <input type="checkbox"/> CL <input type="checkbox"/> FR <input type="checkbox"/> MP <input type="checkbox"/> LS	<input type="checkbox"/> -ST ⁴ 4' Stem <input type="checkbox"/> -BC 10' Black Cord <input type="checkbox"/> -WC 10' White Cord <input type="checkbox"/> -LV ³ 10' Low Voltage Aircraft Cable	-0	<input type="checkbox"/> (blank) (standard canopy) <input type="checkbox"/> -CC1 ⁵ (Conduit 3-1/4" canopy) <input type="checkbox"/> -CC2 (Conduit 3-7/8" canopy)
	<input type="checkbox"/> -15 (15W)		<input type="checkbox"/> 30 (3000K/90 CRI)								
	<input type="checkbox"/> -20 (20W)		<input type="checkbox"/> 35 (3500K/90 CRI)								
	<input type="checkbox"/> -25 (25W)		<input type="checkbox"/> 40 (4000K/90 CRI)								

*Note: Warm dim max wattage is 10W
*For CCT that are out of range, please consult factory
*Note: Can only fit 1 media if HEX or WW is selected

1. Includes larger canopy
2. Forward and reverse dimming at 120V only
3. Damp Location Rated
4. Stem kit includes: (1) x 6", (2) x 12", (1) x 18"
5. CCT1 and CCT2 only for S driver option

Media

<input type="checkbox"/> S3-LENS-CL-0 (Clear Lens)	<input type="checkbox"/> S3-LENS-LS-0 (Linear Spread)
<input type="checkbox"/> S3-LENS-FR-0 (Frosted Lens)	<input type="checkbox"/> S3-LENS-HEX-0* (Hex Louver)
<input type="checkbox"/> S3-LENS-MP-0 (Solite Lens)	<input type="checkbox"/> S3-LENS-WW-0* (Wall Wash)

*Note: Can only fit 1 media if HEX or WW is selected

Emergency

<input type="checkbox"/> EM-1000 (25W LED Remote Inverter)
<input type="checkbox"/> EM-1002 (10W LED Remote Emergency Driver)

Spec:00254 Revised 07/13/2022

Patent: www.cslighting.com/patents

14508 Nelson Ave. City of Industry, CA 91744 • tel: 626.336.4511 • fax: 626.330.4266 • www.cslighting.com
©2021 Creative Systems Lighting, A Division of Troy-CSL Lighting, Inc. All rights reserved. Subject to change without notice.



Catalog
Information:

LP3-SFT-20-S-35-50-MB-WW-NL-BC-0

Date:02/22/2023

Fixture Type:

B18



Features

Kurba Max Vertical is a direct view, high output, energy efficient and flexible LED strip suitable for wet locations capable of vertical/top bends up to 2.5" radius. Built with robust factory made power feeds or joiners, Kurba Max Vertical mounts to a specifically designed aluminum extruded channel. Note: Color temperature of Kurba Max may not exactly match other profiles.

- Applications**
Outdoor wet location
- Operating Voltage**
24VDC
- Operating Temperature**
-40°F to 113°F (-40°C to 45°C)
- Average Life**
50,000 hours

- Dimming**
Low voltage dimmer and class 2 dimming power supply required
- Approvals**
Class 2 wet listed, IP67
- Warranty**
3 years



Technical Information

Model	KBX-SF-V	CCT INFO / LUMEN MULTIPLIER	
		Color Temperature	Multiplier (ref. -3000K)
LEDs/ft	43	2200K	0.98
Light Output at 3000K	458 lm/ft	2700K	1.01
Average Power Consumption at 4'	5.4 W/ft	3000K	1.00
Ordering Increment	1.97"	3500K	1.08
Maximum Run Length (In Series)	18 ft	4000K	1.04

Constraints

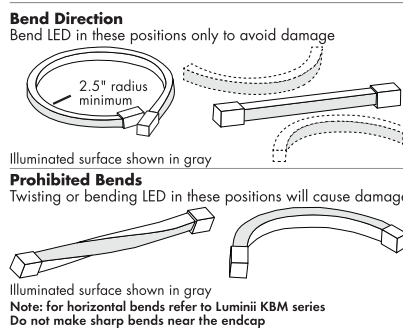

Power Feed Locations

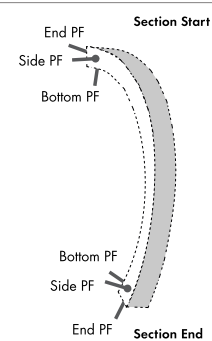

Section Start/End Power Feed Options

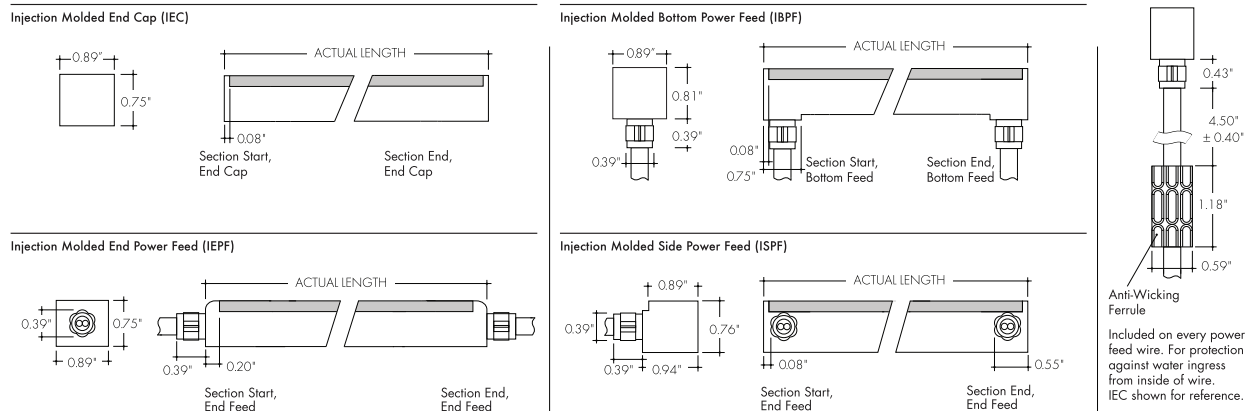

Ordering Code

MODEL	CCT	SECTION START	SECTION END	ACTUAL LENGTH
KBX-SF-V - Kurba Max, Flat, Vertical/Top Bend	22K - 2200K 27K - 2700K 30K - 3000K 35K - 3500K 40K - 4000K	IEC - Injection Molded End cap ¹ IEPF - Injection Molded End power feed (9" wire lead) ¹ IBPF - Injection Molded Bottom power feed (9" wire lead) ¹ ISPF - Injection Molded side power feed (9" wire lead) ^{1,2}	IEC - Injection Molded End cap ¹ IEPF - Injection Molded End power feed (9" wire lead) ¹ IBPF - Injection Molded Bottom power feed (9" wire lead) ¹ ISPF - Injection Molded Side power feed (9" wire lead) ^{1,2}	See Power Consumption table on page 3 for available lengths.

1 - 6-8 weeks lead time. Kurba injected-molded orders are non-cancellable. IEPF, IBPF, ISPF cannot be mixed and matched from Start to End except with IEC.
2 - ISPF Side power feeds selected for both Section Start and End will be located on the same side of the strip.

Mounting Accessories & Optional Connectors

MC-NFS-KBX-F-78

Mounting Channel with Grip, 78"

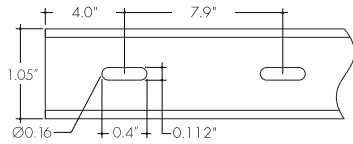
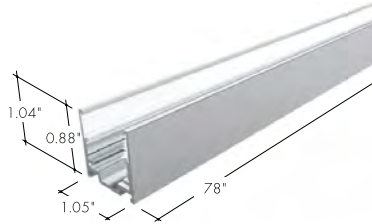

Aluminum mounting channel providing grip. For use with light strip mounted to the ceiling.

MB-KBX-F-ST

Mounting Bracket with Grip, 78"

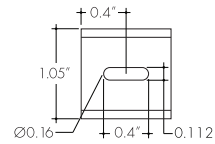
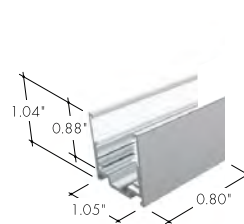

Aluminum mounting bracket providing grip. For use with light strip mounted to the ceiling. 1 recommended every 8 in.

LVSP-WET

Splice Box

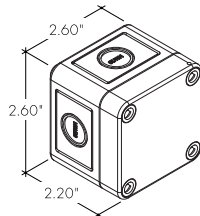

Wet rated, low voltage splice box, gray.

LVSP-WET-CM

Connector

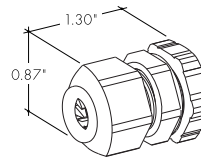

Low voltage splice box wet cable management, gray.

Power Consumption Per Fixture Length

Based on operation with PDCU series of power supplies. Use Actual Length for Order Code Entry
 Tolerance for Actual Lengths less than 6 ft is +/- 0.2", Actual Lengths between 6 ft and 16 ft is +/- 0.3", and Actual Lengths greater than 16 ft is +/- 0.6"

Nominal Length (in)	Actual Length (in)					Actual Length (in)					Actual Length (in)					Actual Length (in)				
	W	IEPF IEPF	IEC IEPF	IEC IBFP ISPF	Nominal Length (in)	W	IEPF IEPF	IEC IEPF	IEC IBFP ISPF	Nominal Length (in)	W	IEPF IEPF	IEC IEPF	IEC IBFP ISPF	Nominal Length (in)	W	IEPF IEPF	IEC IEPF	IEC IBFP ISPF	
2	-	-	-	-	65	27.4	65.4	65.2	65.1	128	53.8	128.4	128.2	128.1	195	81.9	195.3	195.2	195	
4	-	-	-	-	67	28.2	67.3	67.2	67.1	130	54.6	130.3	130.2	130.1	197	82.7	197.3	197.1	197	
6	2.6	6.3	6.2	6.1	69	29.1	69.3	69.2	69.1	(11 ft) 132	55.5	132.3	132.2	132	199	83.5	199.2	199.1	199	
8	3.5	8.3	8.2	8	(6 ft) 71	29.9	71.3	71.1	71	134	56.3	134.3	134.1	134	201	84.3	201.2	201.1	200.9	
10	4.3	10.2	10.1	10	73	30.7	73.2	73.1	73	140	58.8	140.2	140	139.9	199	83.5	199.2	199.1	199	
(1 ft) 12	5.1	12.2	12.1	12	75	31.5	75.2	75.1	75	142	59.6	142.1	142	141.9	201	84.3	201.2	201.1	200.9	
14	5.9	14.2	14.1	13.9	77	32.4	77.2	77.1	76.9	(12 ft) 144	60.4	144.1	144	143.9	(17 ft) 203	85.2	203.2	203	202.9	
16	6.8	16.1	16	15.9	79	33.2	79.1	79	78.9	146	61.2	146.1	145.9	145.8	205	86	205.1	205	204.9	
18	7.6	18.1	18	17.9	81	34	81.1	81	80.9	148	62.1	148	147.9	147.8	207	86.8	207.1	207	206.9	
20	8.4	20.1	20	19.8	(7 ft) 83	34.8	83.1	83	82.8	150	62.9	150	149.9	149.8	209	87.6	209.1	208.9	208.8	
22	9.2	22.1	21.9	21.8	85	35.7	85	84.9	84.8	152	63.7	152	151.9	151.7	211	88.5	211	210.9	210.8	
(2 ft) 24	10.1	24	23.9	23.8	87	36.5	87	86.9	86.8	154	64.5	153.9	153.8	153.7	213	89.3	213	212.9	212.8	
26	10.9	26	25.9	25.8	89	37.3	89	88.9	88.7	(13 ft) 156	65.4	155.9	155.8	155.7	215	90.1	215	214.8	214.7	
28	11.7	28	27.8	27.7	91	38.1	91	90.8	90.7	158	66.2	157.9	157.8	157.6	(18 ft) 217	90.9	216.9	216.8	216.7	
30	12.5	29.9	29.8	29.7	93	39	92.9	92.8	92.7	160	67	159.8	159.7	159.6						
32	13.4	31.9	31.8	31.7	95	39.8	94.9	94.8	94.6	162	67.8	161.8	161.7	161.6						
34	14.2	33.9	33.7	33.6	(8 ft) 97	40.6	96.9	96.7	96.6	164	68.7	163.8	163.7	163.5						
(3 ft) 36	15	35.8	35.7	35.6	99	41.4	98.8	98.7	98.6	166	69.5	165.8	165.6	165.5						
38	15.8	37.8	37.7	37.6	101	42.3	100.8	100.7	100.6	(14 ft) 168	70.3	167.7	167.6	167.5						
40	16.7	39.8	39.7	39.5	103	43.1	102.8	102.6	102.5	170	71.1	169.7	169.6	169.5						
42	17.5	41.7	41.6	41.5	105	43.9	104.7	104.6	104.5	172	72	171.7	171.5	171.4						
44	18.3	43.7	43.6	43.5	107	44.7	106.7	106.6	106.5	174	72.8	173.6	173.5	173.4						
46	19.1	45.7	45.6	45.4	(9 ft) 109	45.6	108.7	108.5	108.4	176	73.6	175.6	175.5	175.4						
(4 ft) 48	20	47.6	47.5	47.4	111	46.4	110.6	110.5	110.4	178	74.4	177.6	177.4	177.3						
50	20.8	49.6	49.5	49.4	113	47.2	112.6	112.5	112.4	(15 ft) 180	75.3	179.5	179.4	179.3						
52	21.6	51.6	51.5	51.3	115	48	114.6	114.5	114.3	182	76.1	181.5	181.4	181.3						
54	22.4	53.5	53.4	53.3	117	48.9	116.5	116.4	116.3	183	76.9	183.5	183.4	183.2						
56	23.3	55.5	55.4	55.3	119	49.7	118.5	118.4	118.3	185	77.7	185.4	185.3	185.2						
57	24.1	57.5	57.4	57.2	(10 ft) 120	50.5	120.5	120.4	120.2	187	78.6	187.4	187.3	187.2						
(5 ft) 59	24.9	59.5	59.3	59.2	122	51.3	122.4	122.3	122.2	189	79.4	189.4	189.3	189.1						
61	25.7	61.4	61.3	61.2	124	52.2	124.4	124.3	124.2	(16 ft) 191	80.2	191.3	191.2	191.1						
63	26.6	63.4	63.3	63.2	126	53	126.4	126.3	126.1	193	81	193.3	193.2	193.1						

Injection Molded End Cap (IEC)

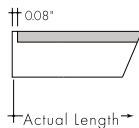

Injection Molded End Power Feed (IEPF)

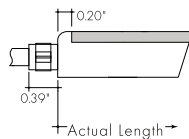

Injection Molded Bottom Power Feed (IBPF)

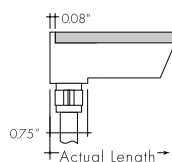

Injection Molded Side Power Feed (ISPF)

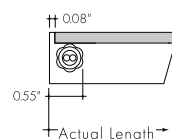

Power Supplies

See Power Supply instructions and spec sheet for wiring information. For a complete list of compatible dimmers, see Compatible Dimming Chart on the Resources page.

Universal Power Supply 1% 120VAC - 277VAC

MODEL	POWER	OUTPUT
PDCU-D - IP20 Dry Series	30 - 30 W 60 - 60 W 96 - 96 W 3X96 - 3X96 W	24 - 24 VDC
PDCU-W - IP66 Wet Series	96 - 96 W 3X96 - 3X96 W	

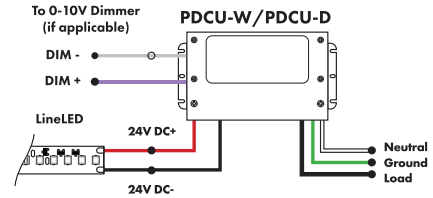

0-10V dims down to 1%, MLV/ELV/TRIAC dims down to 1%. For a complete list of compatible dimmers, see [Compatible Dimming Chart](#) on the Resources page.

MODELS	PDCU-W 96W	PDCU-W 3X96W	PDCU-D 30W	PDCU-D 60W	PDCU-D 96W	PDCU-D 3X96W
Length	8.66"	11.85"	6.10"	7.93"	8.25"	9.57"
Width	3.73"	4.32"	3.35"	3.35"	4.10"	5.94"
Depth	1.61"	1.81"	1.33"	1.32"	1.56"	1.13"

0-10V Dimming Power Supplies 0.1% 120VAC - 277VAC

MODEL	POWER	OUTPUT	DIMMING
PS010V - 0-10V Power Supply dims down to 0.1%	96 - 96 Watt 3X96 - 3 X 96 Watt	24 - 24 VDC	LIN - Linear LOG - Logarithmic

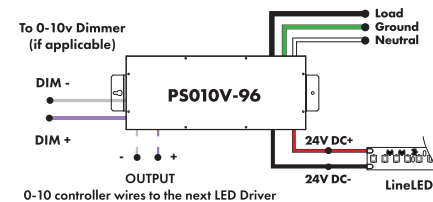

MODELS	96W	3X96
Length	14.40"	15.75"
Width	5.20"	6.62"
Depth	2.60"	4.95"

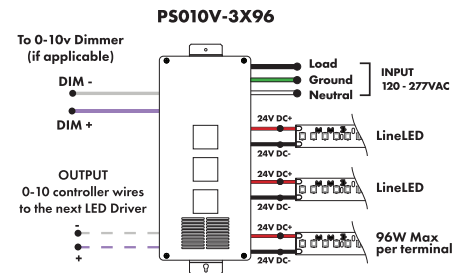

Triac, MLV, ELV, & PWM Compatible Dimmers

MODEL	POWER	OUTPUT
PDC - [IP20] Power Supply	96 - 96 Watts	24 - 24 VDC

MODELS	96W
Length	8.25"
Width	4.10"
Depth	1.56"

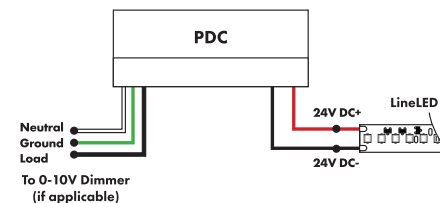

Power Supplies

See Power Supply instructions and spec sheet for wiring information. For a complete list of compatible dimmers, see Compatible Dimming Chart on the Resources page.

DMX Dimming Power Supplies 120VAC - 277VAC

MODEL	POWER	OUTPUT
PSDMX - DMX Power Supply dims down to 0%	96 - 96 Watt 3X96 - 3 X 96 Watt	24 - 24 VDC

Features eldoLED's LINEARdrive configurable dimmable drivers

MODELS	96W	3X96
Length	14.40"	15.75"
Width	5.20"	6.62"
Depth	2.60"	4.95"

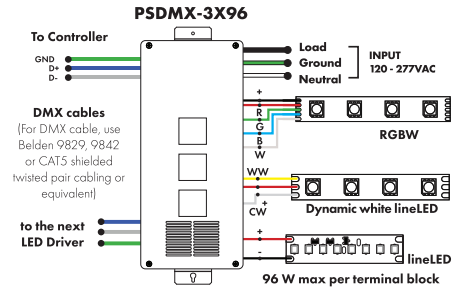
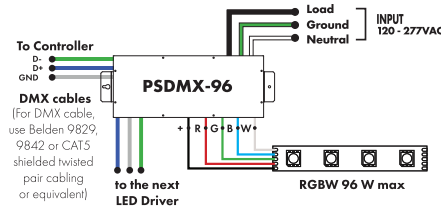

DALI 0% Dimming Power Supplies 120VAC - 277VAC

MODEL	POWER	OUTPUT
PSDALI - DALI Power Supply dims down to 0%	96 - 96 Watt 3X96 - 3 X 96 Watt	24 - 24 VDC

Features eldoLED's LINEARdrive configurable dimmable drivers

Model	96W	3X96
Length	14.40"	15.75"
Width	5.20"	6.62"
Depth	2.60"	4.95"

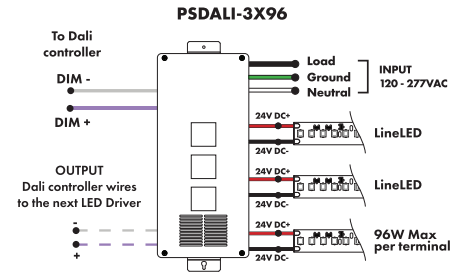
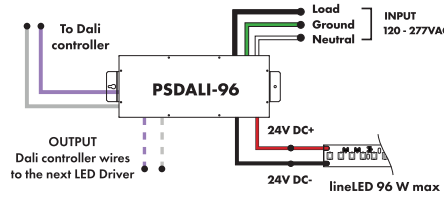

Enlighted Enabled Dimming Power Supplies 120VAC - 277VAC

MODEL	POWER	OUTPUT	DIMMING	LOCATION
PSV - PSV Series	96 - 96 Watt	24 - 24 VDC	ENL - Enlighted Dimming dims down to 0%	D - Damp

Model	96W
Length	14.40"
Width	5.20"
Depth	2.60"

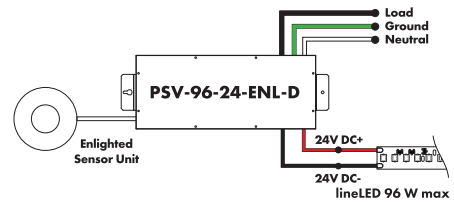

Power Supplies

See Power Supply instructions and spec sheet for wiring information. For a complete list of compatible dimmers, see Compatible Dimming Chart on the Resources page.

Non-Dimming Power Supply 120VAC - 277VAC

MODEL	POWER	OUTPUT	DIMMING	LOCATION
PSV - PSV Series	96 - 96 Watt	24 - 24 VDC	U2ND - Non Dimming	D - Damp

MODELS	96W
Length	14.40"
Width	5.20"
Depth	2.60"

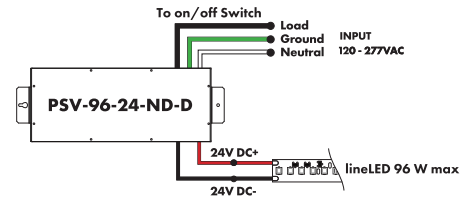

Luminii is a Lutron OEM Advantage Partner

Lutron Power Supplies 1%

MODEL	MODEL
LTEA4U1UKL-CV240	L3DA4U1UKL-CV240
Lutron - HiLume™ 1% 2-wire LED Driver 40W max (120V forward phase only)	HiLume™ 1% EcoSystem Voltage LED driver 40W max

MODELS	LTEA4U1UKL-CV240	L3DA4U1UKL-CV240
Length	4.89"	4.98"
Width	4.00"	4.00"
Depth	2.62"	2.62"

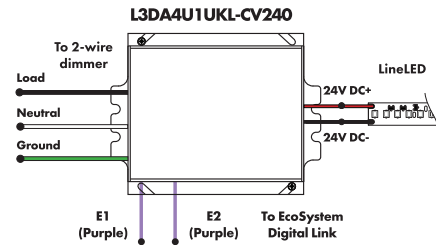
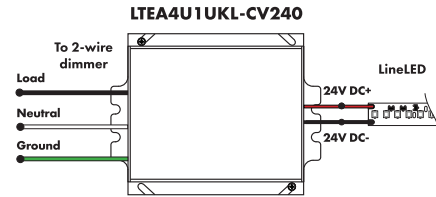

Luminii is a Lutron OEM Advantage Partner

Lutron Power Supplies 0.1%

MODEL
L3D0-96W24V-U
HiLume™ 0.1% EcoSystem Voltage LED Driver with Soft-On, Fade-to-Black™ 96W max

MODELS	L3D0
Length	10.50"
Width	5.50"
Depth	2.00"

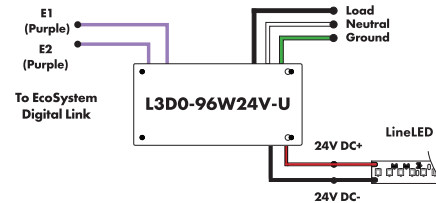

In-Ground Power Supplies

MODEL	POWER	OUTPUT	INPUT
IG - In ground CVE Series	CVE - ELV Dimming DALI - eldoLED Dali dimming Both dims down to 0%	96X2 - 2 X 96 Watt	24 - 24 VDC
			Blank - 120 V 277 - 240/277 V

MODELS	Dual Circuit
Length	8.40"
Width	8.30"
Depth	8.10"

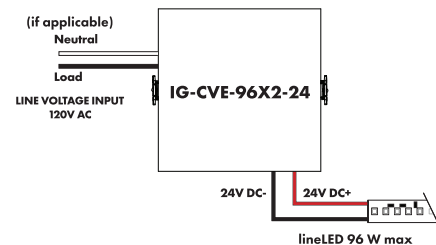

MILLENIUM STRETCH™

MLHA5 SERIES – VANITY

PRODUCT FEATURES:

- » Surface mount – wall; 5" x 24" and 48"
- » Extruded aluminum housing with decorative end caps
- » Low-profile –ADA compliant
- » Peace of Mind Guarantee® against breakage

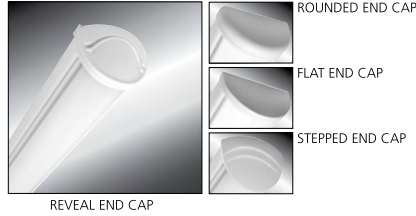

PROJECT INFORMATION

Job Name _____

Fixture Type _____

Catalog Number _____

Approved by _____

SPECIFICATIONS

HOUSING: Marine grade aluminum. Extruded body with die-cast end caps. Housing, with end caps, post assembly TGIC polyester powder coat finished – 5-step pre-treatment. See Ordering Information for standard, optional and custom finishes.

REFLECTOR: Full reflector/wire cover – 92% reflectivity.

LENS: UV-stabilized, high impact extruded pearlescent polycarbonate. Smooth exterior, linear prismatic interior. Nominal thickness .156". Lens securely positioned in body channels and end caps. Lens locked in place with tamper-resistant stainless steel Torx® with center pin fasteners and sealed with closed cell gaskets.

END CAPS: Marine grade die-cast aluminum. Four styles available: Flat, Rounded, Reveal and Stepped.

HARDWARE: Four stainless steel, tamper-resistant Torx® with center pin fasteners secure lens in housing body's lens channel.

ELECTRICAL: Available 3500K, 4000K and 5000K color temperatures, 82 CRI. 120-277VAC and 347VAC, 50/60Hz electrical input with serviceable high power factor electronic, constant-current driver (<20% THD, >0.95 PF). Standard 0-10V dimming with 1-100% range and dim-to-dark capabilities; maximum driver source of 165µA. Consult factory for fluorescent options.

SENSOR & CONTROLS: Optional sensor available with compatible third party controls. To see the full list of compatible controls, [click here](#).

INSTALLATION: Standard two-point (24" housing) or four-point (48" housing) mounting required for Peace of Mind Guarantee®.

PHOTOMETRICS: Photometry tested to the IESNA LM-79-08 standard by an ILAC/ISO17025 accredited laboratory. For additional photometric data, please go to [www.kenall.com](#).

WARRANTY: limited ten (10) year warranty for LED Lamps. [Peace of Mind Guarantee against breakage](#).

LISTINGS: Luminaire is certified to UL Standards by Intertek Testing Laboratory for Damp Location— horizontal and vertical wall mount. ADA compliant.



ORDERING INFORMATION (Ex: MLHA5V-48-F-MB-PP-45L40K-DCC-DV-FS)

Model	Length	End Cap	Finish	Lens	Lamp Type	Driver	Voltage	Options	Accessories
MLHA5V						DCC			
Length	24 2' 48 4'				Lamp Type			Options	
End Caps	F Flat R Rounded RV Reveal SP Stepped				2' Lengths 25L35K 25 Watt 3500K LED 25L40K 25 Watt 4000K LED 25L50K 25 Watt 5000K LED			LEL Integral 8.4W Emergency Battery Backup (45L only; 0°C minimum operating temperature; n/a with 347V) CDF Captive Diffuser Fasteners FS Single Fuse & Holder NAT Natatorium Environment Option PH Phillips Head Fasteners	
Finish	MW Matte White MB Matte Black LG Light Gray CC Custom Color (Consult Factory)				4' Lengths 45L35K 45 Watt 3500K LED 45L40K 45 Watt 4000K LED 45L50K 45 Watt 5000K LED			Accessories 9500 Torx® Screwdriver D-0552 Torx® Driver Bit (Required for CMB Option)	
Lens	PP Pearlescent Polycarbonate				Driver DCC Dimming Constant Current				
					Voltage 120 120 Volts 277 277 Volts 347 347 Volts DV 120-277 Volts				



www.kenall.com | P: 800-4-Kenall | F: 262-891-9701 | 10200 55th Street Kenosha, Wisconsin 53144, USA

A brand of **legrand**

This product complies with the Buy American Act: manufactured in the United States with more than 50% of the component cost of US origin. It may be covered by patents found at [www.kenall.com/patents](#). Content of specification sheets is subject to change; please consult [www.kenall.com](#) for current product details. ©2022 Kenall Mfg. Co.

MLHA5V-021419



Catalog Information:

MLHA5V-48-F-[FINISH]-PP-45L35K-DCC-DV-LEL

Date: 01/27/2023

Fixture Type:

D1

Page: 1 of 2

MILLENNIUM STRETCH™

MLHA5 SERIES – VANITY

PERFORMANCE

Length	Lamp Type	Initial Delivered Lumens		Input Power (W)	Drive Current (mA)	Estd. L70 LED Life (Hrs)
		@ 25°C	Efficacy (lm/W)			
2'	25L35K	2,374	95	25	100	150,000
	25L40K	2,531	101	25	100	150,000
	25L50K	2,531	101	25	100	150,000
4'	45L35K	4,748	97	49	100	150,000
	45L40K	5,062	103	49	100	150,000
	45L50K	5,062	103	49	100	150,000

Information above is valid for the recommended Type PP lens type and is subject to change without notice. Visit www.kenall.com for additional information.

Model: MLHA5-48-F-MW-PP-1-45L40K-DCC-1-DV

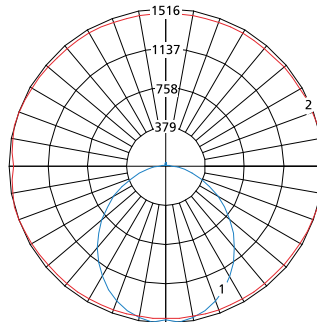

Maximum Candela = 1516 Located At Horizontal Angle = 15, Vertical Angle = 5

- 1 - Vertical Plane Through Horizontal Angles (15-195) (Through Max. Cd.)
- 2 - Horizontal Cone Through Vertical Angle (5) (Through Max. Cd.)

DIMENSIONAL DATA

CROSS SECTION/DETAILS

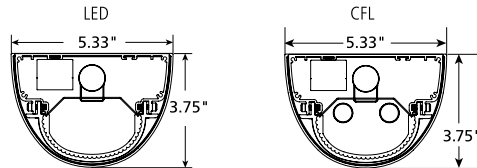

MOUNTING HOLES

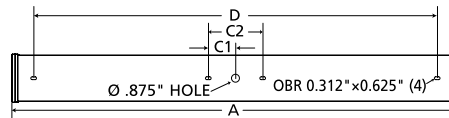

	A	B	C1	C2	D
R	26.524	22.250	N/A	N/A	20.480
F	25.308	22.250	N/A	N/A	20.480
SP	28.131	22.250	N/A	N/A	20.480
RV	27.674	22.250	N/A	N/A	20.480

	A	B	C1	C2	D
R	50.524	46.250	3.000	6.000	44.480
F	49.308	46.250	3.000	6.000	44.480
SP	52.131	46.250	3.000	6.000	44.480
RV	51.674	46.250	3.000	6.000	44.480



www.kenall.com | P: 800-4-Kenall | F: 262-891-9701 | 10200 55th Street Kenosha, Wisconsin 53144, USA

A brand of **legrand**

This product complies with the Buy American Act: manufactured in the United States with more than 50% of the component cost of US origin. It may be covered by patents found at www.kenall.com/patents. Content of specification sheets is subject to change; please consult www.kenall.com for current product details. ©2022 Kenall Mfg. Co.

MLHA5V-021419



Catalog Information:

MLHA5V-48-F-[FINISH]-PP-45L35K-DCC-DV-LEL

Date: 01/27/2023

Fixture Type:

D1

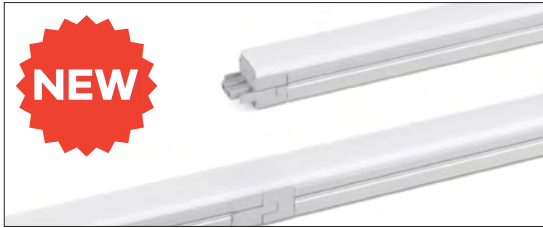

PRODUCT FEATURES

- Line Voltage 100–120V – No Driver Required
- Easy and Quick Snap Connection
- Innovative Slim Design
- Seamless and Spot Free
- Line Voltage Phase Dimming
- Product is approved for Closet/Storage space installation per NEC410.16 (A) (3) and NEC410.16 (C)(5) per NRTL certification
- Compatible with 3rd party dimmers
- Flicker Free
- Various accessories option

PRODUCT SPECIFICATIONS

- Voltage : AC 100–120V
- Operating Temperature : 0–45°C (32–113°F)
- Lamp Life : 50,000hr / 70%
- Available Color : 2700K, 3000K, 3500K, 4000K
- Color Rendering : CRI>90
- Beam Angle:130°
- 3 year warranty

MAX. CONNECTION

- 400W in one row (single power feed)

DIMENSIONS

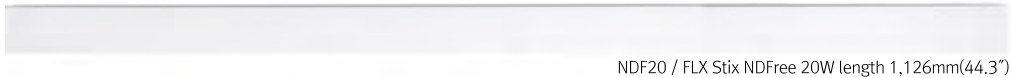
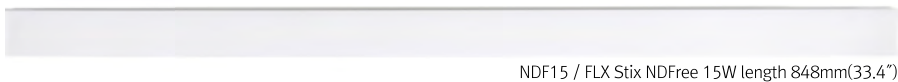

Model Number	Voltage Input (V)	Lamp Power (W)	Lumens(lm) (CRI90)	A mm (inches)	B mm (inches)	C mm (inches)	D mm (inches)	E mm (inches)	F mm (inches)	G mm (inches)
NDF3-(Color)K-120V-C90-FF	AC 100-120V	2.5	212	147 (5.8)	156 (6.1)	178.7 (7)	19 (0.75)	18 (0.71)	18 (0.71)	16.8 (0.66)
NDF5-(Color)K-120V-C90-FF	AC 100-120V	5.34	340	282.5 (11.1)	291.5 (11.5)	314 (12.4)	19 (0.75)	18 (0.71)	18 (0.71)	16.8 (0.66)
NDF10-(Color)K-120V-C90-FF	AC 100-120V	10.93	720	560.5 (22)	569.5 (22.4)	592 (23.3)	19 (0.75)	18 (0.71)	18 (0.71)	16.8 (0.66)
NDF15-(Color)K-120V-C90-FF	AC 100-120V	16.08	1,080	839 (33)	848 (33.4)	870.5 (34.3)	19 (0.75)	18 (0.71)	18 (0.71)	16.8 (0.66)
NDF20-(Color)K-120V-C90-FF	AC 100-120V	21.3	1,440	1,117 (43.4)	1,126 (44.3)	1,148.5 (45.2)	19 (0.75)	18 (0.71)	18 (0.71)	16.8 (0.66)

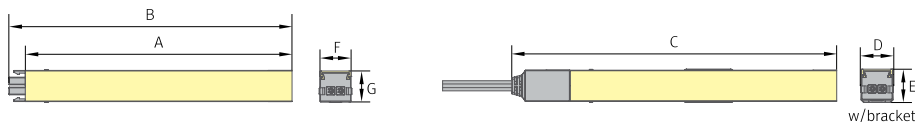

FEELUX Lighting, Inc., 3000 Northwoods Parkway, Suite 165, Peachtree Corners, GA 30071 | Tel: 678.668.7005 | feeluxlighting.com | customerservice@feeluxlighting.com
 If you have any questions, please contact your local Feelux Representative. Specifications subject to change without notice. All Rights Reserved. © 2022 Feelux Lighting, Inc.

NDFree 1 of 4
1/2023

* LED 90° Connector
NDF3 40K-120V-C90-FF-90

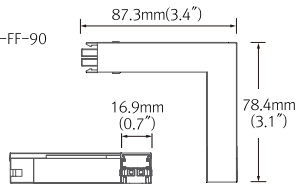

* Flexible Connector

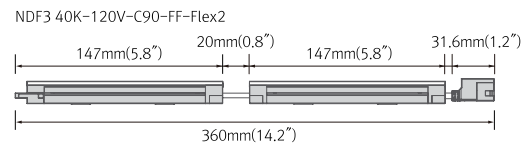

* NDF ON/OFF Switch

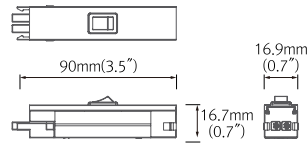

NDF3 40K-120V-C90-FF-Flex3

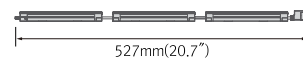

NDF3 40K-120V-C90-FF-Flex5



* LED Power Cord

NDF3 40K-120V-C90-FF-PC / OPC

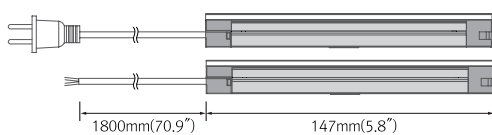

* NDF PENDANT

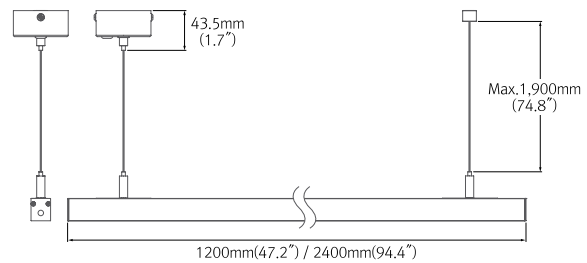

* NDF Extrusion Line

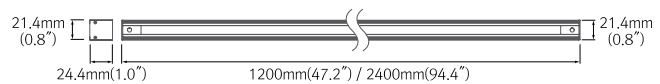

BEAM SPREADS

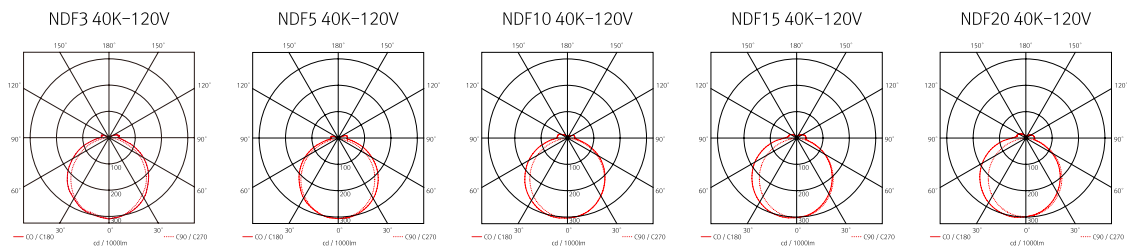

EASY CONNECTION



VARIOUS OPTIONS



FEELUX Lighting, Inc., 3000 Northwoods Parkway, Suite 165, Peachtree Corners, GA 30071 | Tel: 678.668.7005 | feeluxlighting.com | customerservice@feeluxlighting.com
If you have any questions, please contact your local Feelux Representative. Specifications subject to change without notice. All Rights Reserved. © 2022 Feelux Lighting, Inc.

NDFree 2 of 4
1/2023

INSTALLATION

☆ Before Installation (Power Connection)

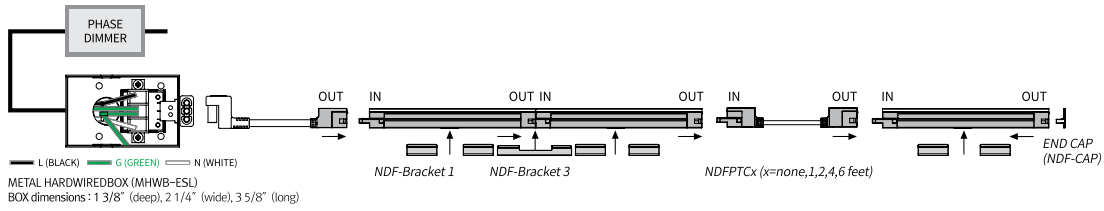

☆ After Installation

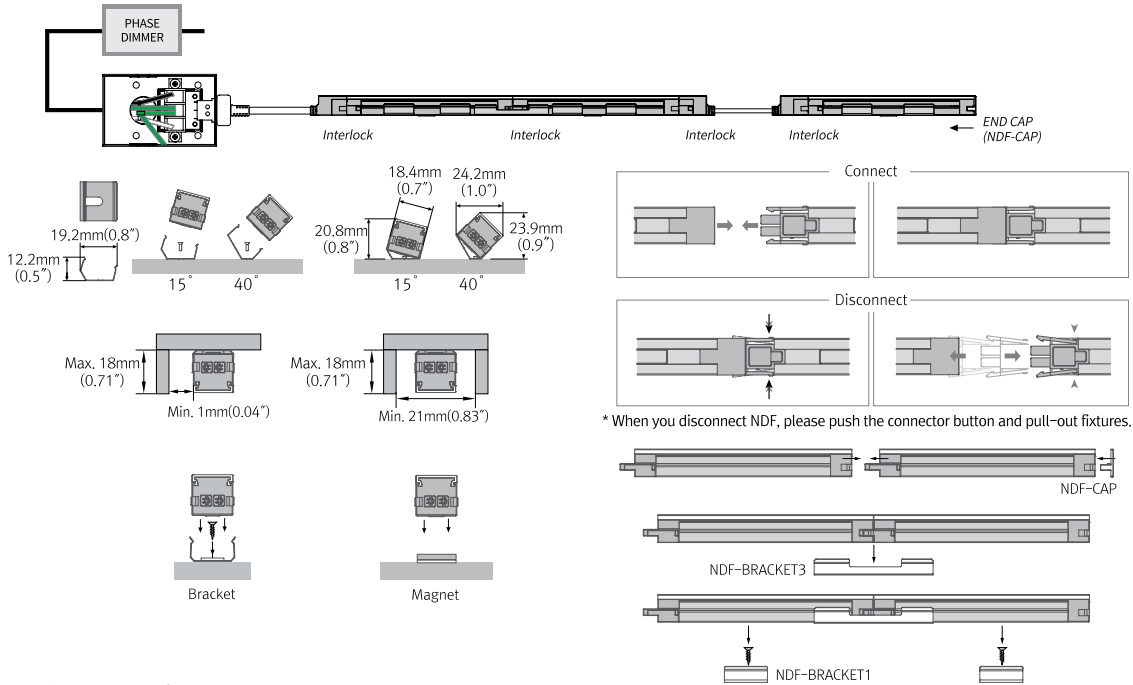



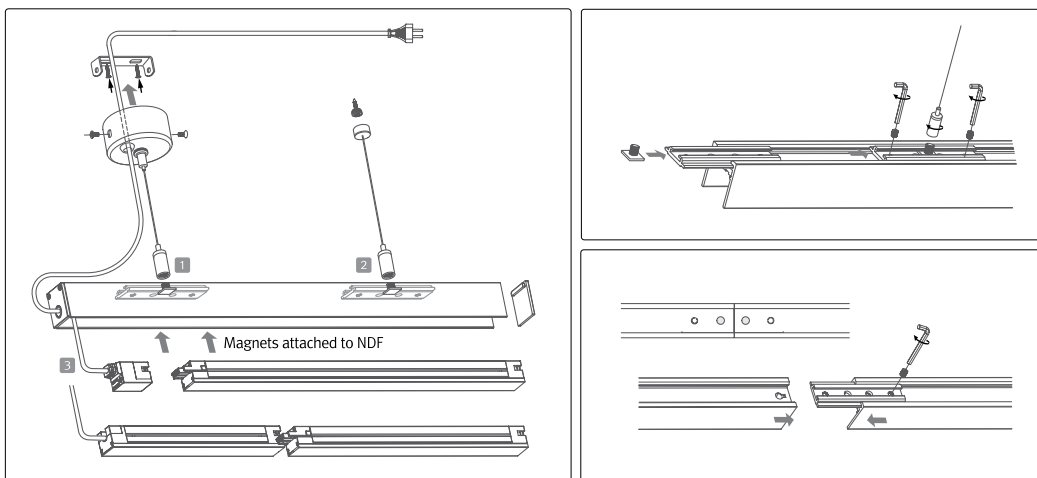



☆ Pendant Installation



FEELUX Lighting, Inc., 3000 Northwoods Parkway, Suite 165, Peachtree Corners, GA 30071 | Tel: 678.668.7005 | feeluxlighting.com | customerservice@feeluxlighting.com
 If you have any questions, please contact your local Feelux Representative. Specifications subject to change without notice. All Rights Reserved. © 2022 Feelux Lighting, Inc.

NDFree 3 of 4
 1/2023

COMPONENTS

	LED Power connector __NDF3-(Color)K-120V-PC NDF3 (5,8") fixture with 6' power cord		Power Cord __NDFPC/XL (6')		Mounting Bracket __NDF-BRACKET1 Included with fixture
	LED open power connector __NDF3-(Color)K-120V-OPC NDF3 (5,8") fixture with 6' open power cord		Open Power Cord __NDFOPC/XL (6')		Angle bracket __NDF-BRACKET2
	LED 90° Connector __NDF3-(Color)K-120V-90		Connecting Cable __NDFPTC/XL (6") __NDFPTC1/XL (1') __NDFPTC2/XL (2') __NDFPTC4/XL (4') __NDFPTC6/XL (6')		Connecting bracket __NDF-BRACKET3 Included with fixture
	Flexible Connector __NDF3-(Color)K-120V-Flex2 (14,15") __NDF3-(Color)K-120V-Flex3 (20,53") __NDF3-(Color)K-120V-Flex5 (32,")		Hard wire box Cable __ESLNDFPTC/XL (6") __ESLNDFPTC1/XL (1') __ESLNDFPTC2/XL (2') __ESLNDFPTC4/XL (4') __ESLNDFPTC6/XL (6") Interface cable between NDF & Hard wire box		Suspension bracket __NDF-SK-BRACKET Suspension Bracket for NDF
	On/Off Switch __NDF-SW		End Cap __NDF-CAP Included with fixture		Suspension Power Kit __NDF-SK-POWER Suspension Power Kit for NDF
	Hard Wire Box __MHWB-ESL		NDF Extrusion line __NDF-EXL (1.2m) __NDF-EXL (2.4m)		Dimming Interface (Dail) __FDS-H1DA-SR Max. 200W (200W/CH,1CH)
					Dimming Interface (Bluetooth) __FDS-H1B-SR Max. 200W (100W/CH,1CH)
					Dimming Interface (Dail) __FDS-H2DA-SR Max. 288W (144W/CH,2CH)

Project		Catalog #		Type	
Prepared by		Notes		Date	



McGraw-Edison

Impact Elite LED

Wall Mount Luminaire

Interactive Menu

- Ordering Information [page 2](#)
- Product Specifications [page 2](#)
- Energy and Performance Data [page 3](#)
- Control Options [page 4](#)

Product Certifications



Quick Facts

- 15 Optical Distributions
- Lumen packages range from 2,459 to 11,480 (20W - 95W)
- Efficacy up to 149 lumens per watt

Connected Systems

- WaveLinx
- Enlighted

Dimensional Details

Cylinder

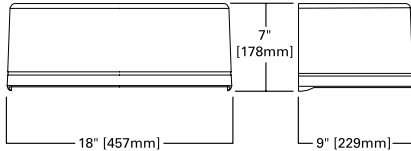

Quarter Sphere

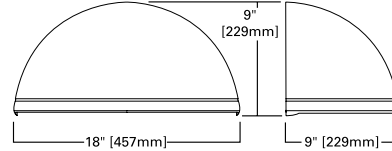

Hook - n - Lock

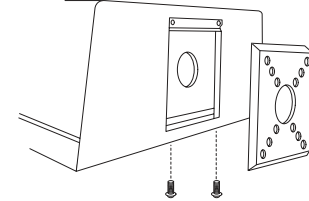

Trapezoid

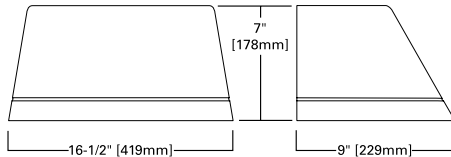

Wedge

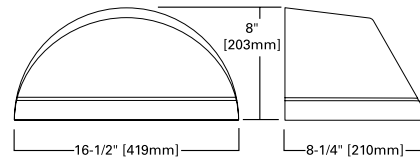

NOTES:

1. IDA Certified for 3000K CCT and warmer only.



PS500049EN page 1
November 17, 2022 12:59 PM



Catalog Information:

IST-SA1-B-740-U-T4FT-[FINISH]-CBP-TR

Date:02/15/2023

Fixture Type:

L1

Ordering Information

SAMPLE NUMBER: ISC-SA1F-740-U-T3-BZ

Product Family ¹	Light Engine		Color Temperature	Voltage	Distribution	Finish
	Configuration	Drive Current				
ISC=Impact Elite LED Small Cylinder ISS=Impact Elite LED Small Quarter Sphere IST=Impact Elite LED Small Trapezoid ISW=Impact Elite LED Small Wedge BAA-ISC=Impact Elite LED Small Cylinder Buy American Act Compliant ²⁴ TAA-ISC=Impact Elite LED Small Cylinder Trade Agreements Act Compliant ²⁴ BAA-ISS=Impact Elite LED Small Quarter Sphere Buy American Act Compliant ²⁴ TAA-ISS=Impact Elite LED Small Quarter Sphere Trade Agreements Act Compliant ²⁴ BAA-IST=Impact Elite LED Small Trapezoid Buy American Act Compliant ²⁴ TAA-IST=Impact Elite LED Small Trapezoid Trade Agreements Act Compliant ²⁴ BAA-ISW=Impact Elite LED Small Wedge Buy American Act Compliant ²⁴ TAA-ISW=Impact Elite LED Small Wedge Trade Agreements Act Compliant ²⁴	SA1=1 Square (16 LED) PA1=1 Panel (24 LED) ²⁷	A=350mA B=450mA C=600mA D=900mA E=1000mA F=1200mA ²	722=70CRI, 2200K 727=70CRI, 2700K 730=70CRI, 3000K 735=70CRI, 3500K 740=70CRI, 4000K 750=70CRI, 5000K 760=70CRI, 6000K 827=80CRI, 2700K 830=80CRI, 3000K AMB=Amber, 590nm ^{3,4}	U=120-277V 1=120V 2=208V 3=240V 4=277V 8=480V ^{2,5} 9=347V ²	SA1 Optics T2=Type II T3=Type III T4FT=Type IV Forward Throw T4W=Type IV Wide SL2=Type II w/Spill Control SL3=Type III w/Spill Control SL4=Type IV w/Spill Control SLR=90° Spill Light Eliminator Left SLR=90° Spill Light Eliminator Right RW=Rectangular Wide Type I PA1 Optics SWQ=Type V Square Wide T2R=Type II Urban T3=Type III Urban T4W=Type IV Wide	AP=Grey BZ=Bronze BK=Black DP=Dark Platinum GM=Graphite Metallic WH=White
Options (Add as Suffix)	Controls and Systems Options (Add as Suffix)			Accessories (Order Separately) ²⁵		
X=Driver Surge Protection (6kV) Only ¹⁷ 20k=Series 20kV ILL 1449 Surge Protective Device CBP=Battery Pack with Back Box, Cold Weather Rated ^{18,19} CBP=CCO=Battery Pack with Back Box, Cold Weather Rated, CEC compliant ¹⁹ HSS=Factory Installed House Side Shield ¹⁶ ULG=Uplight Glow ^{6,7,26} LCF=Light Square Trim Plate Painted to Match Housing TR=Tamper Resistant Hardware CC=Coastal Construction ²⁴ HA=50°C High Ambient ⁸ AHD145=After Hours Dim, 5 Hours, 50% ⁹ AHD245=After Hours Dim, 6 Hours, 50% ⁹ AHD255=After Hours Dim, 7 Hours, 50% ⁹ AHD355=After Hours Dim, 8 Hours, 50% ⁹	BPC=Button Type Photocontrol (120, 208, 240 or 277V. Must Specify Voltage) PR7=NEMA 7-PIN Twistlock Photocontrol Receptacle ^{2,6,7} SPB1=Dimming Occupancy Sensor with Bluetooth Interface, <8' Mounting ^{12,23} SPB2=Dimming Occupancy Sensor with Bluetooth Interface, 8'-20' Mounting ^{12,23} SPB4=Dimming Occupancy Sensor with Bluetooth Interface, 21'-40' Mounting ^{12,23} MS-DIM-LXX=Motion Sensor for Dimming Operation ^{6,10,11,15} LWR-LW=Enlightened Wireless Sensor, Wide Lens for 8'-16' Mounting Height ^{6,12,13} LWR-LN=Enlightened Wireless Sensor, Narrow Lens for 16'-40' Mounting Height ^{6,12,13} ZW=WaveLinX-enabled 4-PIN Twistlock Receptacle ⁷ ZD=SR Driver-enabled 4-PIN Twistlock Receptacle ⁷ ZW-WOBXX=WaveLinX Lite, Dimming Motion and Daylight, Bluetooth Programmable, 7' - 15' Mounting ^{7,18,20} ZW-WOFLX=WaveLinX Lite, Dimming Motion and Daylight, Bluetooth Programmable, 15' - 40' Mounting ^{7,18,20} ZD-WOBXX=WaveLinX Lite, SR Driver, Dimming Motion and Daylight, Bluetooth Programmable, 7' - 15' Mounting ^{7,18,20} ZD-WOFLX=WaveLinX Lite, SR Driver, Dimming Motion and Daylight, Bluetooth Programmable, 15' - 40' Mounting ^{7,18,20} ZW-SWPD4XX=WaveLinX Pro, Dimming Motion and Daylight, WAC Programmable, 7' - 15' Mounting ^{7,18,20} ZW-SWPD5XX=WaveLinX Pro, Dimming Motion and Daylight, WAC Programmable, 15' - 40' Mounting ^{7,18,20} ZD-SWPD4XX=WaveLinX Pro, SR Driver, Dimming Motion and Daylight, WAC Programmable, 7' - 15' Mounting ^{7,18,20} ZD-SWPD5XX=WaveLinX Pro, SR Driver, Dimming Motion and Daylight, WAC Programmable, 15' - 40' Mounting ^{7,18,20}			MA1253=10kV Circuit Module Replacement MA1254-XX=Thruway Back Box - Impact Elite Trapezoid MA1255-XX=Thruway Back Box - Impact Elite Cylinder MA1256-XX=Thruway Back Box - Impact Elite Quarter Sphere MA1257-XX=Thruway Back Box - Impact Elite Wedge FSIR-100=Wireless Configuration Tool for Occupancy Sensor WOLC-7P-10A=WaveLinX Outdoor Control Module (7-pin) ^{2,19} WOB-XX=WaveLinX Lite Sensor, Dimming Motion and Daylight, Bluetooth Programmable, 7' - 15' Mounting ^{7,18,20,21} WOF-XX=WaveLinX Lite Sensor, Dimming Motion and Daylight, Bluetooth Programmable, 15' - 40' Mounting ^{7,18,20,21} SWPD4-XX=WaveLinX Sensor, Dimming Motion and Daylight, WAC Programmable, 7' - 15' Mounting ^{7,18,20,21} SWPD5-XX=WaveLinX Sensor, Dimming Motion and Daylight, WAC Programmable, 15' - 40' Mounting ^{7,18,20,21}		
NOTES: 1. DesignLight Consortium® Qualified. Refer to www.designlights.org , Qualified Products List under Family Models for details. 2. Not available with ULG option. 3. Choose Drive Current "B" for Amber 590nm, which is provided at 500mA only 4. Narrow-band 590nm +/- 5nm for wildlife and observatory use. Choose drive current A; supplied at 500mA drive current only. Exact luminaire wattage available in IES files. Available with SWQ, 5M0, SL2, SL3 and SL4 distributions. Can be used with HSS option. 5. 480V not to be used with ungrounded or impedance grounded systems. 6. Not available with ISB or ISW. 7. Cannot be used in conjunction with other control options. 8. Suitable for 50°C provided no options other than motion sensor are included and driver output set to 1000mA or less. 9. Requires the use of photocontrol. Not available with 350mA drive current. See After Hours Dim supplemental guide for additional information. 10. Replace LXX with L08 (<8' mounting), L20 (8'-20' mounting) or L40W (21'-40' mounting). 11. The FSIR-100 configuration tool is required to adjust parameters including high and low modes, sensitivity, time delay, cutoff and more. Consult your lighting representative at Cooper Lighting Solutions for more information. 12. Includes integral photocell. 13. Enlighted wireless sensors are factory installed and require network components in appropriate quantities. 14. Battery pack operating temperature of -20C to +40C. Operates downlight for 90-minutes. 15. Must specify 120V or 277V. 16. Not for use with 5N0, 5M0, 5W0 or RW optics. A black trim plate is used when HSS is selected. 17. Removes additional surge module. 18. Replace XX with sensor color (WH, BZ, or BK). 19. Requires PR7. 20. For WaveLinX applications, WAC Gateway required to enable field-configurability: Order WAC-PoE and WPOE-120 (10V to PoE injector) power supply if needed. Gateway not required for WaveLinX Lite Commercial (LC) applications. 21. Requires ZW or ZD receptacle. 22. Coastal construction finish salt spray tested to over 5,000-hours per ASTM B117, with a scribe rating of 9 per ASTM D1654. 23. Smart device with mobile application required to change system defaults. See controls section for details. 24. Only product configurations with these designated prefixes are built to be compliant with the Buy American Act of 1933 (BAA) or Trade Agreements Act of 1979 (TAA), respectively. Please refer to DOMESTIC.PREFERENCES website for more information. Components shipped separately may be separately analyzed under domestic preference requirements. 25. For BAA or TAA requirements, Accessories sold separately will be separately analyzed under domestic preference requirements. Consult factory for further information. 26. Only available in 3000K, 4000K or 5000K CCT. 27. Not available with motion sensor controls, including SPB, MS/DIM, LWR or WaveLinX.						

Thruway Back Box

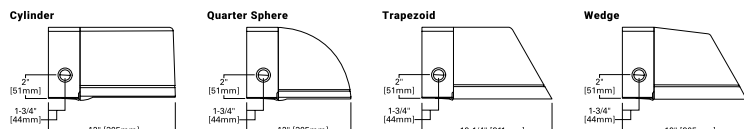

Product Specifications

- | | | |
|---|--|---|
| <p>Construction</p> <ul style="list-style-type: none"> Heavy-wall, die-cast aluminum housing and removable hinged door frame Optional tamper-resistant fasteners offer vandal resistant access IK10 impact rated <p>Optics</p> <ul style="list-style-type: none"> High-efficiency injection-molded AccuLED optics technology 15 optical distributions IDA Certified (3000K CCT and warmer only) | <p>Electrical</p> <ul style="list-style-type: none"> Standard with 0-10V dimming Standard with Cooper Lighting Solutions proprietary circuit module designed to withstand 10kV of transient line surge Suitable for operation in -40°C to 40°C ambient environments. Optional 50°C high ambient (HA) configuration Suitable for operation in -40°C to 40°C ambient environments. Optional 50°C high ambient (HA) configuration. <p>Mounting</p> <ul style="list-style-type: none"> Utilizes "Hook-N-Lock" mounting mechanism, | <p>securing to a gasketed and zinc plated mounting attachment</p> <ul style="list-style-type: none"> Two black oxide coated Allen set screws concealed but accessible from below <p>Finish</p> <ul style="list-style-type: none"> Super durable TGIC polyester powder coat paint, 2.5 mil nominal thickness RAL and custom color matches available Coastal Construction (CC) option available <p>Warranty</p> <ul style="list-style-type: none"> Five year limited warranty, consult website for details. www.cooperlighting.com/legal |
|---|--|---|



PS500049EN page 2
November 17, 2022 12:59 PM



Catalog Information: IST-SA1-B-740-U-T4FT-[FINISH]-CBP-TR

Date:02/15/2023
Fixture Type:

L1

Energy and Performance Data

[View Impact Elite IES files](#)

1 Light Square (SA)		Cylinder (ISC) and Quarter Sphere (ISS)						Trapezoid (IST) and Wedge (ISW)					
Drive Current (mA)		350	450	600	800	1000	1200	350	450	600	800	1000	1200
Power (Watts)	120-277V	20.1	25.4	34.2	45.2	58.2	66.0	20.1	25.4	34.2	45.2	58.2	66.0
Current (A)	120	0.17	0.22	0.29	0.38	0.48	0.56	0.17	0.22	0.29	0.38	0.48	0.56
	277V	0.09	0.10	0.13	0.17	0.21	0.25	0.09	0.10	0.13	0.17	0.21	0.25
Power (Watts)	347V or 480V	23.3	28.7	36.6	49.5	60.7	70.1	23.3	28.7	36.6	49.5	60.7	70.1
Current (A)	347V	0.07	0.08	0.11	0.15	0.18	0.21	0.07	0.08	0.11	0.15	0.18	0.21
	480V	0.05	0.06	0.08	0.11	0.13	0.16	0.05	0.06	0.08	0.11	0.13	0.16
Optics (4000K, 70 CRI)													
T2	Lumens	2,802	3,500	4,618	5,778	7,231	7,895	2,772	3,475	4,576	5,733	7,175	7,834
	BUG Rating	B1-U0-G1	B1-U0-G1	B1-U0-G1	B1-U0-G2	B1-U0-G2	B1-U0-G2	B1-U0-G1	B1-U0-G1	B1-U0-G1	B1-U0-G2	B1-U0-G2	B1-U0-G2
	Lumens Per Watt	139	138	135	128	124	120	138	137	134	127	123	119
T3	Lumens	2,778	3,470	4,578	5,729	7,169	7,827	2,731	3,424	4,508	5,648	7,069	7,718
	BUG Rating	B1-U0-G1	B1-U0-G1	B1-U0-G1	B1-U0-G2	B1-U0-G2	B1-U0-G2	B1-U0-G1	B1-U0-G1	B1-U0-G1	B1-U0-G2	B1-U0-G2	B1-U0-G2
	Lumens Per Watt	138	137	134	127	123	119	136	135	132	125	121	117
T4FT	Lumens	2,751	3,436	4,534	5,673	7,099	7,751	2,762	3,462	4,559	5,712	7,149	7,805
	BUG Rating	B1-U0-G1	B1-U0-G1	B1-U0-G1	B1-U0-G2	B1-U0-G2	B1-U0-G2	B1-U0-G1	B1-U0-G1	B1-U0-G1	B1-U0-G2	B1-U0-G2	B1-U0-G2
	Lumens Per Watt	137	135	133	126	122	117	137	136	133	126	123	118
T4W	Lumens	2,780	3,473	4,582	5,733	7,174	7,833	2,739	3,434	4,522	5,665	7,089	7,740
	BUG Rating	B1-U0-G1	B1-U0-G1	B1-U0-G2	B1-U0-G2	B1-U0-G2	B1-U0-G2	B1-U0-G1	B1-U0-G1	B1-U0-G2	B1-U0-G2	B1-U0-G2	B1-U0-G2
	Lumens Per Watt	138	137	134	127	123	119	136	135	132	125	122	117
SL2	Lumens	2,763	3,451	4,554	5,698	7,130	7,785	2,730	3,422	4,507	5,646	7,066	7,715
	BUG Rating	B1-U0-G1	B1-U0-G1	B1-U0-G1	B1-U0-G2	B1-U0-G2	B2-U0-G2	B1-U0-G1	B1-U0-G1	B1-U0-G1	B1-U0-G2	B1-U0-G2	B2-U0-G2
	Lumens Per Watt	137	136	133	126	123	118	136	135	132	125	121	117
SL3	Lumens	2,745	3,429	4,524	5,660	7,084	7,734	2,709	3,396	4,472	5,603	7,012	7,655
	BUG Rating	B1-U0-G1	B1-U0-G1	B1-U0-G1	B1-U0-G2	B1-U0-G2	B1-U0-G2	B1-U0-G1	B1-U0-G1	B1-U0-G1	B1-U0-G2	B1-U0-G2	B1-U0-G2
	Lumens Per Watt	137	135	132	125	122	117	135	134	131	124	120	116
SL4	Lumens	2,680	3,348	4,417	5,526	6,916	7,551	2,666	3,342	4,401	5,514	6,900	7,534
	BUG Rating	B1-U0-G1	B1-U0-G1	B1-U0-G1	B1-U0-G2	B1-U0-G2	B1-U0-G2	B1-U0-G1	B1-U0-G1	B1-U0-G1	B1-U0-G2	B1-U0-G2	B1-U0-G2
	Lumens Per Watt	133	132	129	122	119	114	133	132	129	122	119	114
SLL	Lumens	2,447	3,057	4,033	5,046	6,315	6,895	2,459	3,083	4,059	5,086	6,365	6,949
	BUG Rating	B1-U0-G1	B1-U0-G1	B1-U0-G1	B1-U0-G1	B1-U0-G2	B1-U0-G2	B1-U0-G1	B1-U0-G1	B1-U0-G1	B1-U0-G1	B1-U0-G2	B1-U0-G2
	Lumens Per Watt	122	120	118	112	109	104	122	121	119	113	109	105
RW	Lumens	2,883	3,601	4,751	5,945	7,440	8,123	2,818	3,533	4,652	5,828	7,294	7,964
	BUG Rating	B2-U0-G1	B2-U0-G1	B2-U0-G1	B3-U0-G1	B3-U0-G1	B3-U0-G1	B2-U0-G1	B2-U0-G1	B2-U0-G1	B3-U0-G1	B3-U0-G1	B3-U0-G1
	Lumens Per Watt	143	142	139	132	128	123	140	139	136	129	125	121



1 Light Panel (PA)		Cylinder (ISC) and Quarter Sphere (ISS)						Trapezoid (IST) and Wedge (ISW)					
Drive Current (mA)		350	450	600	800	1000	1200	350	450	600	800	1000	1200
Power (Watts)	120-277V	28.9	36.4	48.9	63.0	82.4	94.4	28.9	36.4	48.9	63.0	82.4	94.4
Current (A)	120V	0.24	0.31	0.41	0.53	0.69	0.79	0.24	0.31	0.41	0.53	0.69	0.79
	277V	0.11	0.14	0.18	0.23	0.30	0.34	0.11	0.14	0.18	0.23	0.30	0.34
Power (Watts)	347V or 480V	30.5	37.7	49.0	63.9	83.2	95.0	30.5	37.7	49.0	63.9	83.2	95.0
Current (A)	347V OR 480V	0.09	0.11	0.14	0.19	0.24	0.28	0.09	0.11	0.14	0.19	0.24	0.28
	480V	0.07	0.08	0.11	0.14	0.18	0.20	0.07	0.08	0.11	0.14	0.18	0.20
Optics (4000K, 70 CRI)													
T2R	Lumens	4,296	5,369	7,010	8,733	10,721	11,750	4,154	5,211	6,738	8,386	10,329	11,338
	BUG Rating	B1-U0-G1	B1-U0-G1	B1-U0-G2	B1-U0-G2	B1-U0-G2	B2-U0-G2	B1-U0-G1	B1-U0-G1	B1-U0-G2	B1-U0-G2	B1-U0-G2	B2-U0-G2
	Lumens Per Watt	149	147	143	139	130	124	144	143	138	133	125	120
T2U	Lumens	4,241	5,300	6,920	8,621	10,584	11,600	4,123	5,172	6,688	8,323	10,252	11,253
	BUG Rating	B1-U0-G1	B2-U0-G2	B2-U0-G2	B2-U0-G2	B3-U0-G3	B3-U0-G3	B1-U0-G1	B2-U0-G2	B2-U0-G2	B2-U0-G2	B3-U0-G3	B3-U0-G3
	Lumens Per Watt	147	146	142	137	128	123	143	142	137	132	124	119
T3	Lumens	4,193	5,240	6,842	8,524	10,464	11,468	4,079	5,117	6,616	8,235	10,143	11,133
	BUG Rating	B1-U0-G2	B1-U0-G2	B1-U0-G2	B2-U0-G2	B2-U0-G3	B2-U0-G3	B1-U0-G2	B1-U0-G2	B1-U0-G2	B2-U0-G2	B2-U0-G3	B2-U0-G3
	Lumens Per Watt	145	144	140	135	127	121	141	141	135	131	123	118
T4W	Lumens	4,165	5,205	6,796	8,467	10,394	11,392	4,083	5,122	6,623	8,243	10,152	11,144
	BUG Rating	B1-U0-G2	B1-U0-G2	B1-U0-G2	B2-U0-G3	B2-U0-G3	B2-U0-G3	B1-U0-G2	B1-U0-G2	B1-U0-G2	B2-U0-G3	B2-U0-G3	B2-U0-G3
	Lumens Per Watt	144	143	139	134	126	121	141	141	135	131	123	118
5WQ	Lumens	4,255	5,318	6,943	8,650	10,619	11,638	4,206	5,276	6,822	8,491	10,458	11,480
	BUG Rating	B3-U0-G1	B3-U0-G2	B3-U0-G2	B3-U0-G2	B4-U0-G3	B4-U0-G3	B3-U0-G1	B3-U0-G2	B3-U0-G2	B3-U0-G2	B4-U0-G2	B4-U0-G3
	Lumens per Watt	147	146	142	137	129	123	146	145	140	135	127	122

Lumen Maintenance (TM-21)

Drive Current	Ambient Temperature	25,000 hours*	50,000 hours*	60,000 hours*	100,000 hours**	Theoretical L70 hours**
Up to 1A	25°C	99.4%	99.0%	98.9%	98.3%	> 2.4M
	40°C	98.7%	98.3%	98.1%	97.4%	> 1.9M
	50°C	98.2%	97.2%	96.8%	95.2%	> 851,000
1.2A	25°C	99.4%	99.0%	98.9%	98.3%	> 2.4M
	40°C	98.5%	97.9%	97.7%	96.7%	> 1.3M

* Supported by IES TM-21 standards
 ** Theoretical values represent estimations commonly used; however, refer to the IES position on LED Product Lifetime Prediction, IES PS-10-18, explaining proper use of IES TM-21 and LM-80.

Lumen Multiplier

Ambient Temperature	Lumen Multiplier
10°C	1.02
15°C	1.01
25°C	1.00
40°C	0.99



Control Options

0-10V

This fixture is offered standard with 0-10V dimming driver(s).

Photocontrol (BPC and PR7)

Optional button-type photocontrol provides a flexible solution to enable "dusk-to-dawn" lighting by sensing light levels.

After Hours Dim (AHD)

This feature allows photocontrol-enabled luminaires to achieve additional energy savings by dimming during scheduled portions of the night. The dimming profile will automatically take effect after a "dusk-to-dawn" period has been calculated from the photocontrol input. Specify the desired dimming profile for a simple, factory-shipped dimming solution requiring no external control wiring. Reference the After Hours Dim supplemental guide for additional information.

Dimming Occupancy Sensor (SPB, MS/DIM-LXX)

These sensors are factory installed in the luminaire housing. When the SPB or MS/DIM sensor options are selected, the occupancy sensor is connected to a dimming driver and the entire luminaire dims when there is no activity detected. When activity is detected, the luminaire returns to full light output. The MS/DIM sensor is factory preset to dim down to approximately 50 percent power with a time delay of five minutes. SPB motion sensors require the Sensor Configuration mobile application by Wattstopper to change factory default dimming level, time delay, sensitivity and other parameters. Available for iOS and Android devices. The SPB sensor is factory preset to dim down to approximately 10% power with a time delay of five minutes. The MS/DIM occupancy sensors require the FSIR-100 programming tool to adjust factory defaults.

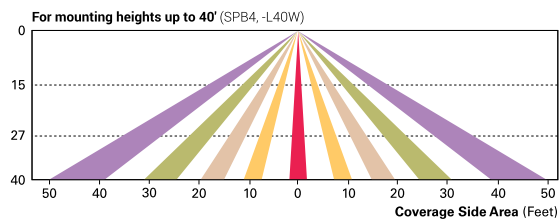
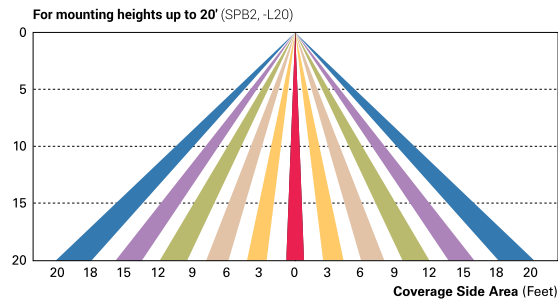
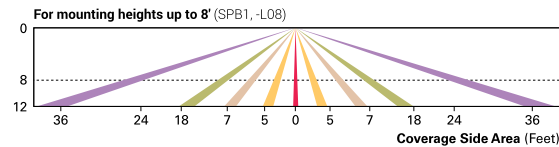

Enlighted Wireless Control and Monitoring System (LWR-LW and LWR-LN)

Enlighted is a connected lighting solution that combines a broad selection of energy-efficient LED luminaires with a powerful integrated wireless sensor system. The sensor controls the lighting system in compliance with the latest energy codes and collects valuable data about building performance and use. Software applications turn the granular data into information through energy dashboards and specialized apps that make it simple and help optimize the use of building resources, beyond lighting.

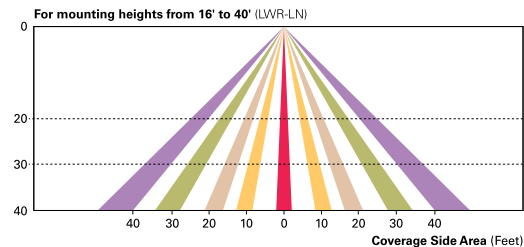
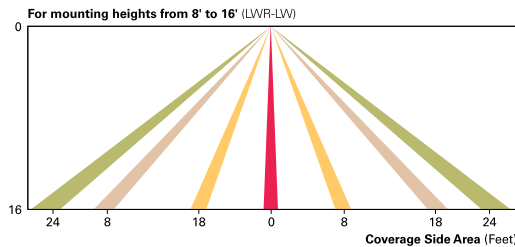

WaveLinx Wireless Control and Monitoring System

Operates on a wireless mesh network based on IEEE 802.15.4 standards enabling wireless control of outdoor lighting. WaveLinx and WaveLinx Lite sensors utilize the Zhaga Book 18 compliant 4-PIN receptacle (ZD or ZW), while the WOLC control module utilizes a 7-PIN receptacle. ZW option provides 4-PIN receptacle and control module to enable future installation of WaveLinx sensors. ZD option provides 4-PIN receptacle and sensor-ready (SR) driver to enable future installation of WaveLinx sensors, power monitoring, and advanced functionality. WaveLinx (SWPD4 to SWPD5) outdoor wireless sensors offer passive infrared (PIR) occupancy and photocell for closed loop daylight harvesting, and can be factory or field-installed. Sensors are factory preset to dim down to 50% after 15 minutes of no motion detected. Two lens options are available for mounting heights of 7' to 40'. Use the WaveLinx mobile application for set-up and configuration. At least one Wireless Area Controller (WAC) is required for full functionality and remote communication (including adjustment of any factory pre-sets). WaveLinx Lite (WOF and WOB) outdoor wireless sensors provide PIR occupancy and photocell for closed loop daylight harvesting, and can be factory or field-installed. Sensors are factory preset to dim down to 50% after 15 minutes of no motion detected. Two lens options are available for mounting heights of 7' to 40'. Use the WaveLinx Lite mobile application for set-up and configuration. WAC not required. WaveLinx Outdoor Control Module (WOLC-7P-10A) accessory provides a photocontrol enabling astronomical or time-based schedules to provide ON, OFF and dimming control of fixtures utilizing a 7-PIN receptacle. The out-of-box functionality is ON at dusk and OFF at dawn.

For mounting heights up to 15' (SWPD4 and WOB)

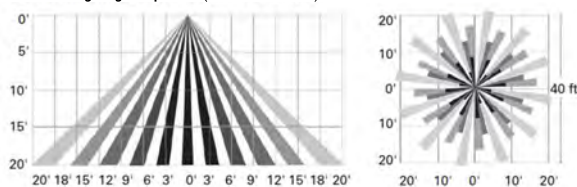

For mounting heights up to 40' (SWPD5 and WOF)

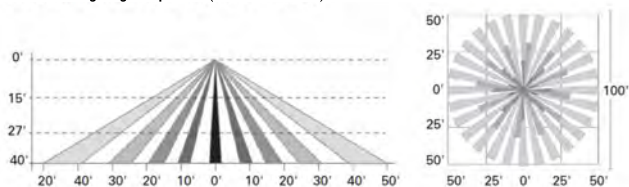

Cooper Lighting Solutions
1121 Highway 74 South
Peachtree City, GA 30269
P: 770-486-4800
www.cooperlighting.com

© 2022 Cooper Lighting Solutions
All Rights Reserved.
Specifications and dimensions
subject to change without notice.

PS500049EN page 5
November 17, 2022 12:59 PM



Catalog Information:

IST-SA1-B-740-U-T4FT-[FINISH]-CBP-TR

Date:02/15/2023

Fixture Type:

L1

Page: 5 of 5

OW2480 PASSAGE™

Mullion Mount with Remote Power Supply



[Visalighting.com/products/Passage](https://visalighting.com/products/Passage)

Type: Project: Location:



DIMENSIONS

Depth is measured from wall to front of fixture

L = Length H = Height D = Depth

L	37-1/4"	(946 mm)
H	2-1/2"	(64 mm)
D	2-1/2"	(64 mm)

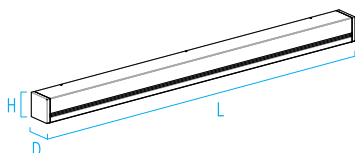

FEATURES

- High or low lumen output
- Luminous or Forward Throw output
- Modular design for replacement of LED source or driver
- Remote power supply included (suitable for indoor, Type IC)
- Optional dual circuit switching
- IP65 rated
- Bracket mounting system simplifies installation and maintenance
- Window mullion mount; minimum mullion width 2.5"
- Tamper resistant fasteners
- Polycarbonate diffuser
- No VOC powder coat paint finish; metal based sublimated wood look finish
- ETL Listed for wet location mounting 4' above grade

RELATIVE SCALE DRAWING

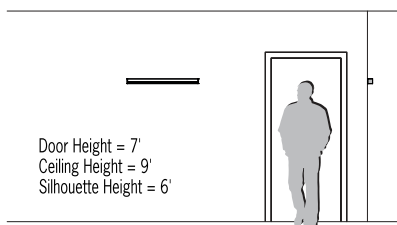

PHOTOMETRICS

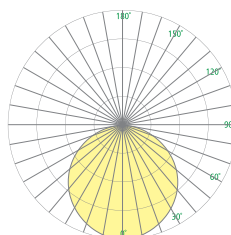

LUM (Luminous Lens)

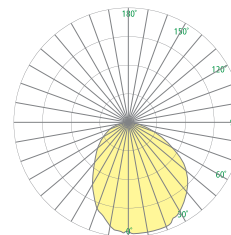

FT (Forward Throw Optic)



IP65



ADA Compliant



ETL Listed



5 Year Warranty



Catalog Information:

OW2480-L35K(H)-MVOLT-FT-VBLK-DS

Date: 12/02/2022

Fixture Type:

L2

OW2480 PASSAGE (cont.)

Mullion Mount with Remote Power Supply



Fill in shaded boxes using information listed below

OW2480		MVOLT			
MODEL	SOURCE¹ L30K(H) L30K(L) L35K(H) L35K(L) L40K(H) L40K(L)	VOLTAGE MVOLT	OPTIC² LUM FT	FINISH See last page for finish order codes	OPTION³ DS

SOURCE¹ (Select one)

Dimmable 0-10V to 1%, Minimum 82CRI, within 3-step MacAdam

Source	CCT	Delivered Forward Throw Lumens	Delivered Luminous Lumens	Power (Watts)
L30K(H)	3000K	2700	1900	40
L30K(L)	3000K	900	650	14
L35K(H)	3500K	2700	1900	40
L35K(L)	3500K	900	650	14
L40K(H)	4000K	2700	1900	40
L40K(L)	4000K	900	650	14

VOLTAGE

MVOLT	120-277V, 50/60 Hz
--------------	--------------------

OPTIC² (Select one)

LUM	Luminous Lens
FT	Forward Throw Optic

OPTION³

▲ Option availability may be interdependent with Other Options

DS	Dual circuit switching (includes 2 drivers). Lumen output and wattage is split in half for each circuit
-----------	--

PATH OF EGRESS - LUMINOUS LENS

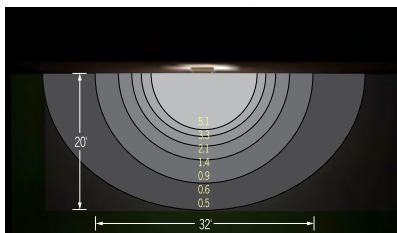

OW2480 -H Downlight, Mounted at 10' AFF, .70 light loss factor used

PATH OF EGRESS - FORWARD THROW

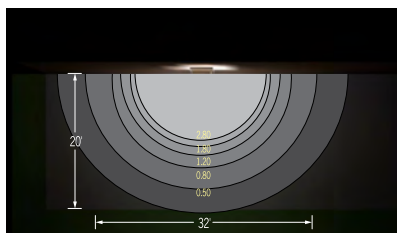

OW2486 -H Downlight, Mounted at 10' AFF, .70 light loss factor used

REMOTE POWER SUPPLY ENCLOSURE

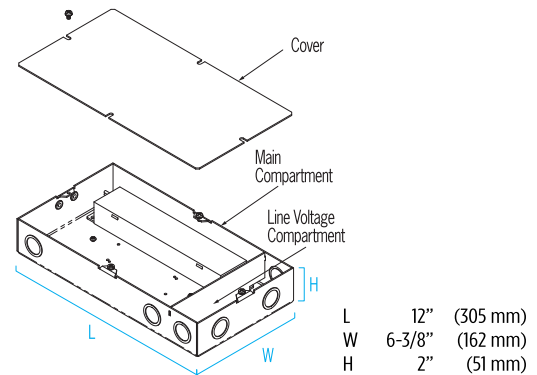

MULLION MOUNTING DETAIL

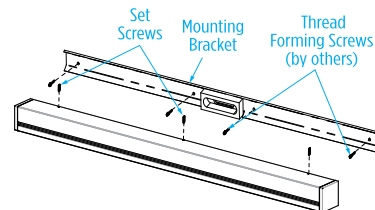

Catalog Information:

OW2480-L35K(H)-MVOLT-FT-VBLK-DS

Date:12/02/2022

Fixture Type:

L2

OW2480 PASSAGE (cont.)

Mullion Mount with Remote Power Supply



PASSAGE PRODUCT FAMILY

- **OW2480 – 37” – Mullion Mount with Remote Power Supply**
- OW2482 – 37” – 2 X 4 Junction Box Mount with Integral Power Supply
- OW2484 – 72” – Mullion Mount with Remote Power Supply
- OW2486 – 72” – 2 X 4 Junction Box Mount with Integral Power Supply

SUGGESTED VARIATIONS

- Custom colors

See [Visalighting.com/products/Passage](https://visalighting.com/products/Passage) for more information

FINISHES

Specify color code when ordering. For accurate color matching, individual paint and finish samples are [available upon request](#). For more information about our finishes visit visalighting.com/finishes

Powder Coat Paint Finishes (Standard)

AGGY Agate Grey	ALGN Alpine Green	BJBG Baja Beige	BMAT Bronze Matte	BRNZ Bronze	BSIL Blade Silver	CVBL Cove Blue
DEOR Deoro Gold	GLWT Glacier White	GSIL Graphite Siver	HRGR Harbor Grey	JTBK Jet Black	OCBL Ocean Blue	SHGR Shoreline Grey
SBGN Sagebrush Green	SLGR Slate Grey	SSTP Sierra Taupe	TRCN Terracotta Canyon	TRWT Traffic White	VBLK Velvet Black	VNRD Vineyard Red

Wood Sublimated Metal Finishes (Premium)

MCA Mediterranean Cherry Metal Based Wood Alternative	NOA Natural Oak Metal Based Wood Alternative

WOOD SUBLIMATED METAL FINISH



This document contains information which is the property of Visa Lighting, and may not, in whole or in part, be duplicated, disclosed, or used for design or manufacturing purposes without the prior written permission of Visa Lighting. ©Visa Lighting. Design Modification Rights Reserved. Visa Lighting reserves the right to change specifications for product improvement without notification.

Date: _____ Customer: _____

Project: _____

Type: _____ Qty: _____



Discera 4



Order Code: DSC4L - - - - -

Pole Order Code: _____ * See pages 8 and 9

<u>DSC4L</u>	Series	DSC4L Discera 4										
	Optics	R1 Type I	R2 Type II	R3 Type III	R3W Type III (Wide)	R4 Type IV	R5R Type V (Round)	DG Diffuse Flat Glass				
	Mounting	S1 Single Short Arm Mount	S2 Double Short Arm (180°) Mount	L1 Single Long Arm Mount	L2 Double Long Arm Mount (180°)	SW Short Arm Wall Mount	LW Long Arm Wall Mount	LG1 Single Long Arm Mount with Gusset	LG2 Double Long Arm Mount with Gusset (180°)	LGW Long Arm Wall Mount with Gusset	C1 Catalys Arm Mount	* See page 8 and 9 for available poles and options. AT524 pole only available for C1 mounting.
	Comfort Light Engine (DG)	MP350 nominal 33W/2965lm	MP530 nominal 48W/4443lm	MP700 nominal 61W/5613lm	MP900 nominal 79W/6951lm	* Based on 3000K CCT * Wattage based on ac input, 347/480V are 8.3% higher						
	Technical Light Engine (R1-R5R)	5G350 nominal 32W/3357lm	5G530 nominal 47W/4875lm	5G700 nominal 62W/6325lm	5G900 nominal 78W/7548lm	* Based on R1 optics and 3000K CCT * Wattage based on ac input, 347/480V are 8.3% higher						
	CCT	27 ¹ 2700K	30 ¹ 3000K	35 3500K	40 4000K	50 5000K	¹ 2700K and 3000K IDA Approved * Consult factory for lead time					
	Power Cord Length	12 12'	15 15'	18 18'	20 20'	25 25'	XX ² XX'	² Add length of arm and height of pole to determine power cord length.				
	Finish	WH White	BL Semi-Matte Black	BK Black	BZ Bronze	SV Silver	SP Specify Premium Color					
	Voltage	UNV 120-277V	120 120V	240 240V	277 277V	347 ³ 347V	480 ³ 480V	³ Step down transformer provided. 5G900 and MP900 not available at 480V.				
	Options	DM ⁴ Dimming (0-10V)	HL30 ^{4,6} Hi-Lo Switching Low Output 30%	HL50 ^{4,5} Hi-Lo Switching Low Output 50%	HS ⁶ House Side Shield (180°)	TLR ^{5,7} 7-pin NEMA socket with shorting cap	TLRP ^{5,7} Twist Lock Receptacle 3-Pin with Photocell	TLRLL ^{5,7} Twist Lock Receptacle 7-Pin with Lutron Limelight Sensor	⁴ 120V, 240V, 277V only ⁵ DM, HLXX, TLR, TLRLL or MS only. Cannot be combined. TLRP or MS only. Cannot be combined. ⁶ Type I, II, III and IV only ⁷ Not available with wall or catalys mountings.			



Selux Corporation © 2022, T 845-834-1400, 800-735-8927, F 845-834-1401, www.selux.us
In a continuing effort to offer the best product possible, we reserve the right to change, without notice, specifications or materials that in our opinion will not alter the function of the product. Specification sheets found at www.selux.us are the most recent versions and supercede all other printed or electronic versions.

Page 1 of 14
(Rev. 04/2022)
DSC4L_SS_v3.0



Catalog Information: LUMINAIRE: DSC4L-R1-S1-5G350-35-[POWER CORD]-[FINISH]-UNV
POLE: A35-14-[FINISH]-T35

Date: 01/27/2023
Fixture Type:

P1

Page: 1 of 14

DSC4L

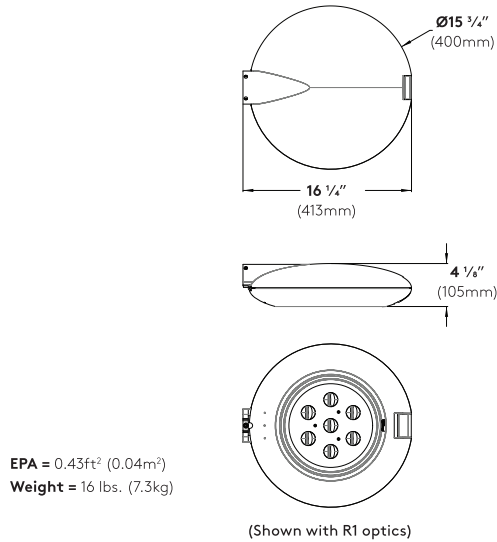

Specifications

Fixture Housing - Made from high pressure die cast, low copper aluminum alloy.

Gasketing - Continuous silicone gasket provides weatherproofing, dust and insect control at all luminaire connections.

LED Array - LEDs mounted to PC boards and attached to aluminum heat sink for maximum LED performance and life. CCT tolerance 3-step binning for 2700K, 3000K, 3500K, 4000K, and 5000K. CRI minimum 80. Complete light engine can be removed easily for future upgrade.

LED Optics - Technical Optics (R1, R2, R3, R3W, R4, and R5R) use Selux signature light pattern acrylic lens holder to secure proprietary silicone optics. Internal micro house side shield available for distributions types I, II, III & IV. Comfort Optics (DG) use mid-power LEDs and highly diffuse dish for uniformity and glare control.

LED Driver - LEDs are driven by RoHS compliant constant current programmable LED driver. Driver includes 0-10V dimming to 10%, meets the requirements of IP65. Driver assembly located inside the head.

Glass Lens - Tempered glass lens protects and seals optical chamber to IP65.

Toolless Latch - Toolless stainless steel latch for easy access to light engine.

Access Door - Lower casting features a stainless steel hinge that attaches to upper casting on mounting arm side. Other side is secured with toolless latch for ease of maintenance.

Surge Protection - Designed to protect luminaire from electrical surge (20kA).

Exterior Luminaire Finish - Selux utilizes a high quality Polyester Powder Coating. All Selux luminaires and poles are finished in our Tiger Drylac certified facility and undergo a five stage intensive pretreatment process where product is thoroughly cleaned, phosphated and sealed. Selux powder coated products provide excellent salt and humidity resistance as well as ultra violet resistance for color retention. All products are tested in accordance with test specifications for coatings from ASTM and PCI.

Standard exterior colors are White (WH), Black (BK), Semi-Matte Black (BL), Bronze (BZ), and Silver (SV). Selux premium colors (SP) are available, please specify from your Selux color selection guide.

5 Year Limited LED Luminaire Warranty - Selux offers a 5 Year Limited Warranty to the original purchaser that the Selux LED luminaire shall be free from defects in material and workmanship for up to five (5) years from date of shipment. This limited warranty covers the fixture, LED driver, and LED light engine when installed and operated according to Selux instructions. Fixture suitable for ambient temperatures between -40°C (-40°F) and 40°C (104°F). For details and exclusions, see "Selux Terms and Condition of Sale."

Listings and Ratings: Luminaire and LEDs tested to IP65, IK09, and IESNA LM-79-08 standards. LEDs tested to LM-80 standards.

Visit selux.us for our LED End of Life recycling policy.

For Buy American compliance on poles, please consult the factory.

Mounting

SW Short Arm Wall
 EPA = 0.39ft² (0.04m²)
 Weight = 23 lbs. (10kg)

S1 Single Short Arm
 EPA = 0.47ft² (0.05m²)
 Weight = 23 lbs. (10kg)

S2 Double Short Arm
 EPA = 1.05ft² (0.10m²)
 Weight = 46 lbs. (21kg)

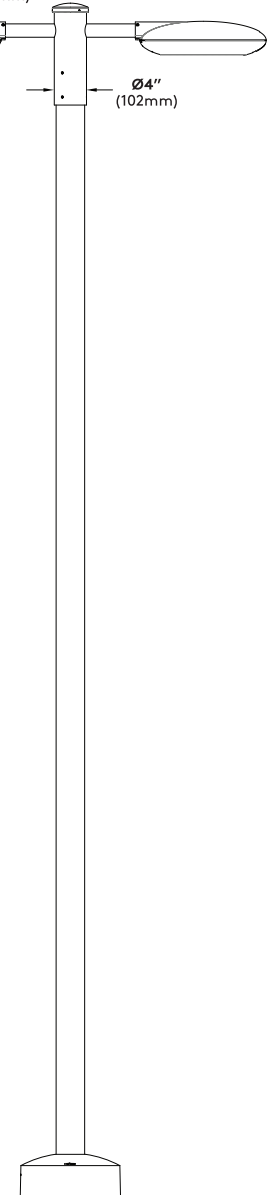
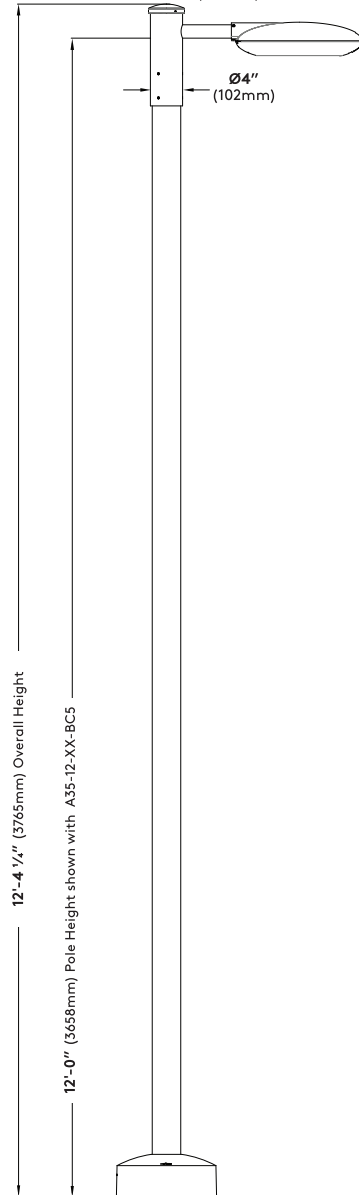
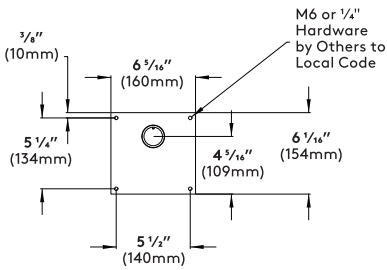
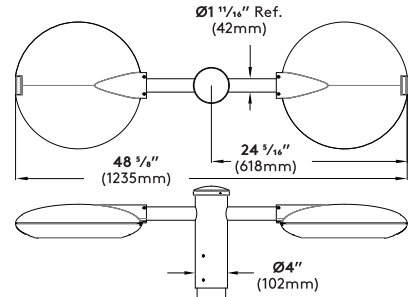
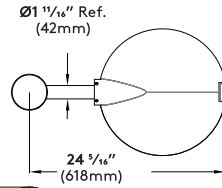
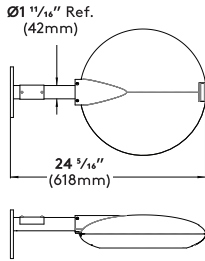

Catalog Information:

LUMINAIRE: DSC4L-R1-S1-5G350-35-[POWER CORD]-[FINISH]-UNV

POLE: A35-14-[FINISH]-T35

Date:01/27/2023
 Fixture Type:

P1

Mounting

LW Long Wall Mount
 EPA = 0.46ft² (0.05m²)
 Weight = 23 lbs. (10kg)

L1 Single Long Arm
 EPA = 0.83ft² (0.08m²)
 Weight = 52 lbs. (23.6kg)

L2 Double Long Arm
 EPA = 1.32ft² (0.13m²)
 Weight = 69.7 lbs. (31.7kg)

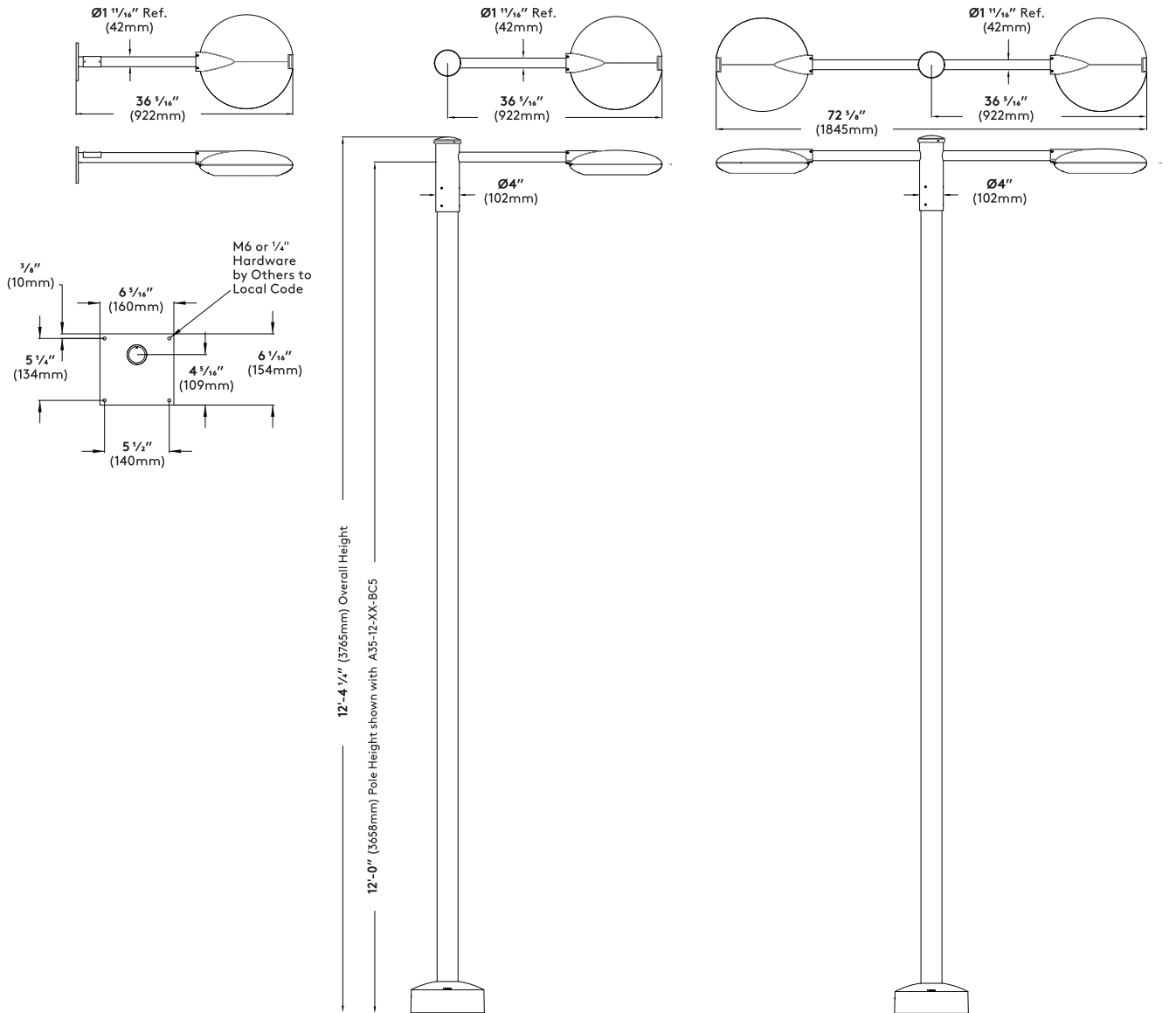

Catalog Information:

LUMINAIRE: DSC4L-R1-S1-5G350-35-[POWER CORD]-[FINISH]-UNV

POLE: A35-14-[FINISH]-T35

Date:01/27/2023
 Fixture Type:

P1

LGW Long Wall Mount with gusset
 EPA = 0.66ft² (0.06m²)
 Weight = 23.5 lbs. (10.7kg)

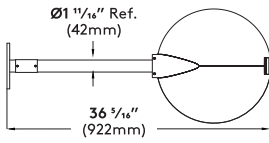

LG1 Single Long Arm with gusset
 EPA = 1.03ft² (0.10m²)
 Weight = 52.5 lbs. (23.8kg)

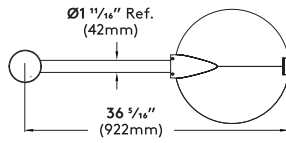

LG2 Double Long Arm with gusset
 EPA = 1.72ft² (0.13m²)
 Weight = 70.7 lbs. (32.1kg)

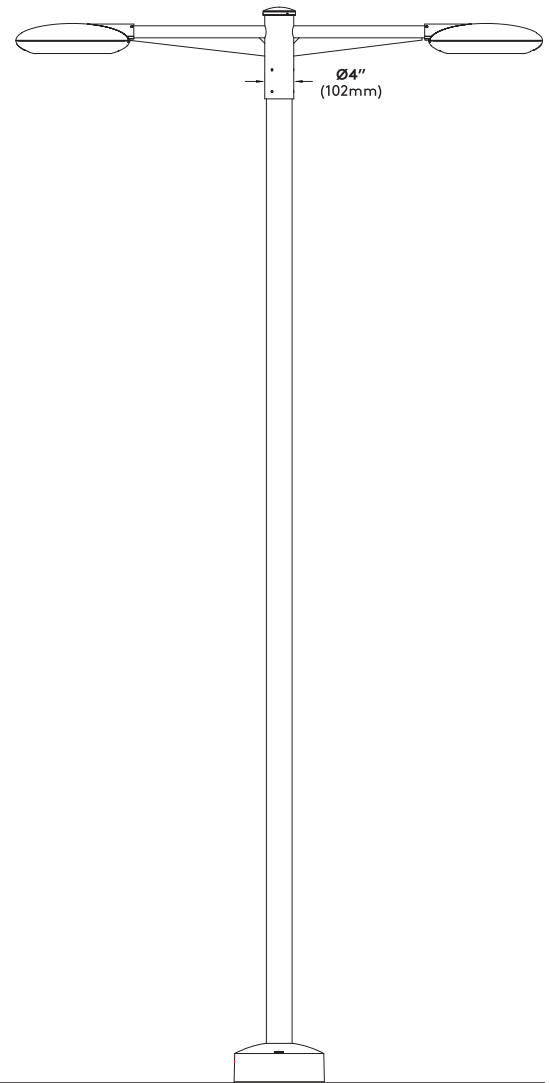
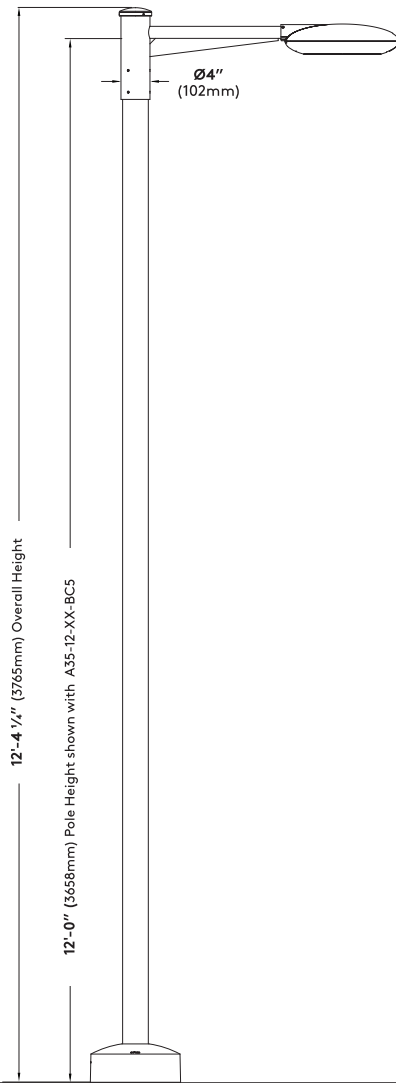
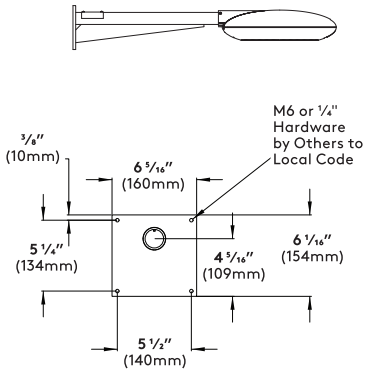
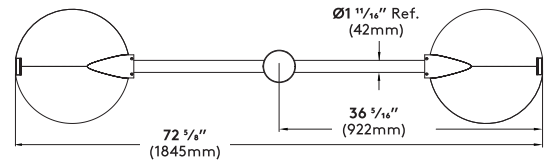

C1 Single Citalys Arm
EPA = .73ft²

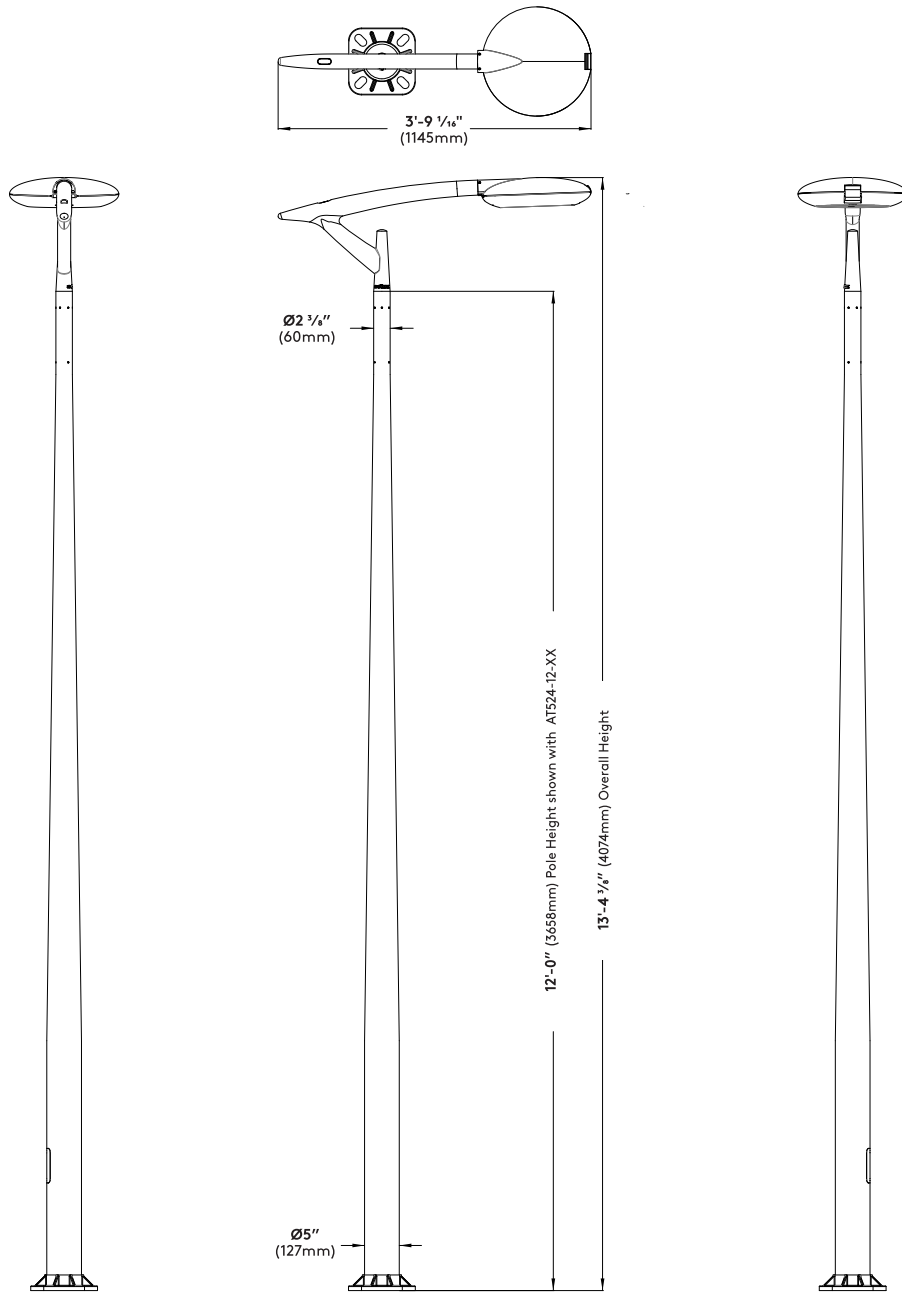

Catalog
Information:

LUMINAIRE: DSC4L-R1-S1-5G350-35-[POWER
CORD]-[FINISH]-UNV

POLE: A35-14-[FINISH]-T35

Date:01/27/2023
Fixture Type:

P1

Pole Information

Refer to pole specification sheets for construction details, anchorage information and additional options.

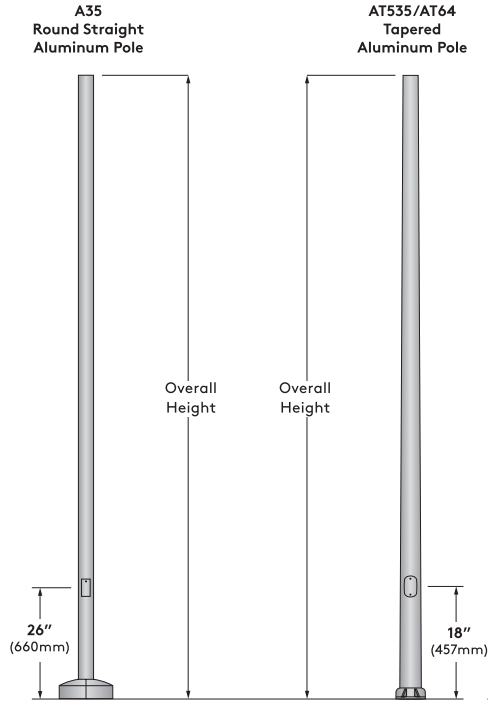

Bolt Circle for A35

Use caution when setting anchor bolts. Bolts must be vertically straight and centered on dimensions shown.

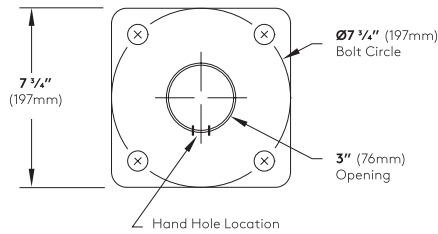

Note: Adequate drainage must be provided in concrete foundation or grout.

Optional Base Covers for Poles

Die cast aluminum, one or two-piece field installable base covers.

BC5 Standard Base Cover (A35)

Die cast aluminum, two-piece field installable base cover.

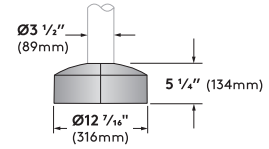

BC9 Optional Base Cover (AT64)

Die cast aluminum, two-piece field installable base cover.

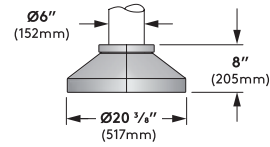

BC3 Optional Base Cover (AT535)

Die cast aluminum, two-piece field installable base cover.

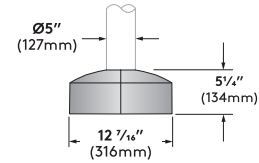

Bolt Circle for AT535

Use caution when setting anchor bolts. Bolts must be vertically straight and centered on dimensions shown.

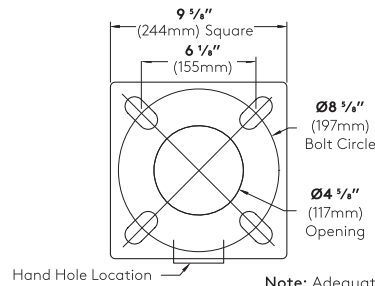

Note: Adequate drainage must be provided in concrete foundation or grout.

Bolt Circle for AT64

Use caution when setting anchor bolts. Bolts must be vertically straight and centered on dimensions shown

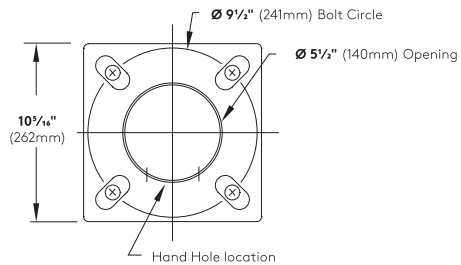

Note: Adequate drainage must be provided in concrete foundation or grout.

Pole Data Chart

Pole Series	Bolt Circle	EPA Information (ft2)											Pole Height	Finish	Options
		85 mph	90 mph	100 mph	110 mph	120 mph	130 mph	140 mph	150 mph	160 mph	170 mph	180 mph			
A35 3 1/2" Round Straight Aluminum Pole	7-3/4"	7.4	6.4	4.9	3.8	2.9	2.2	1.8	1.5	1.2	1.0	0.9	10 10ft	WH White	BC3 Decorative Cast Aluminum Base Cover (AT535 poles only)
A35 3 1/2" Round Straight Aluminum Pole	7-3/4"	5.6	4.8	3.5	2.6	1.8	1.3	0.9	0.7	0.6	-	-	12 12ft	BK Black	BC5 Decorative Cast Aluminum Base Cover (A35 pole only)
AT535 5" to 3 1/2" Round Tapered Aluminum Pole	8-5/8"	15.2	13.4	10.5	8.4	6.9	5.8	4.9	4.2	3.6	3.2	2.8	12 12ft	BL Semi-Matte Black	BC9 Decorative Cast Aluminum Base Cover (AT64 poles only)
A35 3 1/2" Round Straight Aluminum Pole	7-3/4"	4.2	3.5	2.4	1.6	1.0	0.5	-	-	-	-	-	14 14ft	BZ Bronze	REC GFCI Receptacle with weatherproof cover
AT535 5" to 3 1/2" Round Tapered Aluminum Pole	8-5/8"	12.8	11.2	8.7	6.9	5.5	4.6	3.8	3.3	2.8	2.4	2.1	14 14ft	SV Silver	REC2 GFCI Receptacle with padlockable in-use cover
A35 3 1/2" Round Straight Aluminum Pole	7-3/4"	2.7	2.1	1.2	0.6	-	-	-	-	-	-	-	16 16ft	SP Specify Pre-mium Color	REC3 USB & Duplex Receptacle with weatherproof cover
AT535 5" to 3 1/2" Round Tapered Aluminum Pole	8-5/8"	10.5	9.1	6.9	5.4	4.3	3.4	2.9	2.4	2.0	1.7	1.5	16 16ft		REC4 USB & Duplex Receptacle with weatherproof padlockable in-use cover
AT535 5" to 3 1/2" Round Tapered Aluminum Pole	8-5/8"	10.7	9.2	7.0	5.4	4.2	3.4	2.8	2.3	2.0	1.7	1.4	18 18ft		MS* Motion Sensor with Optional Photocell (Meets Title 24 Requirements)
AT64 6" to 4" Round Tapered Aluminum Pole	9-1/2"	13.6	11.9	9.2	7.3	6.0	4.9	4.2	3.5	3.0	2.6	2.2	18 18ft		T35 3 1/2" Tenon (Required for AT64 poles for arm mounting)
AT64 6" to 4" Round Tapered Aluminum Pole	9-1/2"	11.4	9.9	7.5	5.9	4.7	3.9	3.2	2.7	2.3	1.9	1.6	20 20ft		* See page 10 to specify motion sensor details * Weatherproof cover intended for portable tools or other portable equipment connected to the outlet only when attended. For other requirements please consult factory.

Notes:

1. Maximum basic wind speed certified in accordance with AASHTO 2013 (LTS-6).
2. Values are nominal 3-s gust wind speeds in accordance with ASCE 7-05 for Allowable Stress Design (ASD) analysis.



Catalog Information:

LUMINAIRE: DSC4L-R1-S1-5G350-35-[POWER CORD]-[FINISH]-UNV

POLE: A35-14-[FINISH]-T35

Date:01/27/2023
Fixture Type:

P1

Pole Information

Refer to pole specification sheets for construction details, anchorage information and additional options.

AT524 Tapered Aluminum Pole

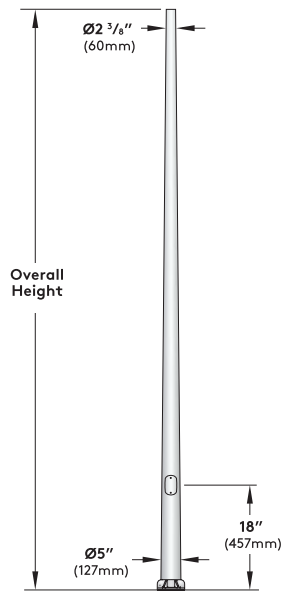

Bolt Circle

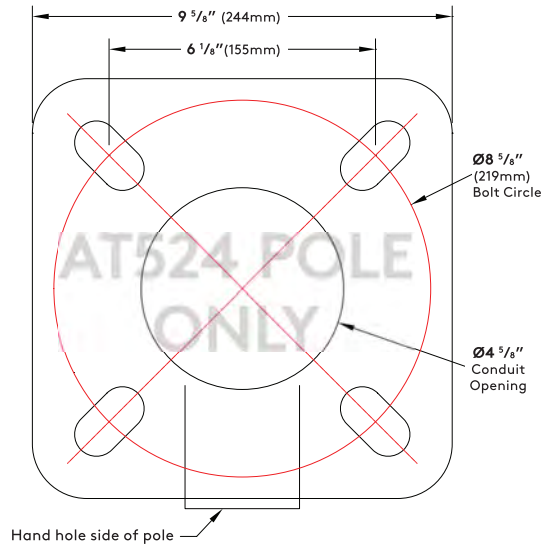

BC3 Optional Base Cover

Die cast aluminum, two piece field installable base cover

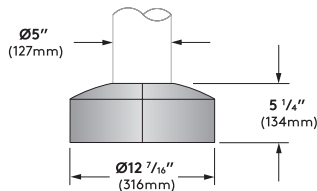

Anchor Bolt Detail

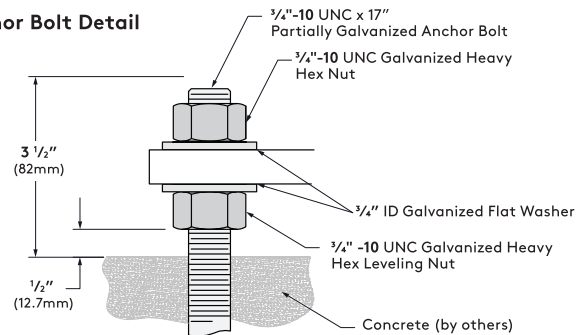

Pole Data Chart

Pole Series	Bolt Circle	Wall	EPA Information (ft ²)											Height	Finish	Options
			85 mph	90 mph	100 mph	110 mph	120 mph	130 mph	140 mph	150 mph	160 mph	170 mph	180 mph			
AT524 5" to 2.4" Round Tapered Aluminium Pole	8 5/8"	.188"	12.6	11.2	9.0	7.4	6.1	5.2	4.4	3.8	3.3	2.9	2.5	10 10ft	WH White BK Black BL Sem-Matte Black BZ Bronze SV Silver SP Specify Premium Color	BC3 Die Cast Two-Piece Aluminum decorative Base Cover REC GFCI Receptacle with weatherproof cover REC2 GFCI Receptacle with padlockable in-use cover REC3 USB & Duplex Receptacle with weatherproof cover REC4 USB & Duplex Receptacle with weatherproof padlockable in-use cover * Weatherproof cover intended for portable tools or other portable equipment connected to the outlet only when attended. For other requirements please consult factory.
			12.6	11.2	9.0	7.4	6.1	5.2	4.4	3.8	3.3	2.9	2.5	12 12ft		
			12.6	11.2	9.0	7.4	6.1	5.2	4.4	3.8	3.3	2.9	2.5	14 14ft		
			12.6	11.2	9.0	7.4	5.8	4.7	3.9	3.2	2.7	2.3	1.9	16 16ft		
			11.2	9.8	7.5	5.8	4.6	3.7	3.0	2.4	2.0	-	-	18 18ft		
			9.4	8.1	6.1	4.7	3.6	2.8	2.2	1.7	1.3	-	-	20 20ft		

Notes:

- 1) Maximum EPA ratings certified in accordance with AASHTO 2013 (LTS-6) for 3-s gust wind speeds based on Allowable Stress Design (ASD) analysis.
- 2) Consult factory for equivalent Load and Resistance Factor Design (LRFD) wind speeds.
- 3) Rated performance is dependant upon the pole being properly attached to a supporting foundation of adequate design.

Selux Corporation © 2022, T 845-834-1400, 800-735-8927, F 845-834-1401, www.selux.us

In a continuing effort to offer the best product possible, we reserve the right to change, without notice, specifications or materials that in our opinion will not alter the function of the product. Specification sheets found at www.selux.us are the most recent versions and supercede all other printed or electronic versions.

Page 9 of 14
(Rev. 04/2022)
DSC4L_SS_v3.0



Catalog Information:

LUMINAIRE: DSC4L-R1-S1-5G350-35-[POWER CORD]-[FINISH]-UNV

POLE: A35-14-[FINISH]-T35

Date:01/27/2023

Fixture Type:

P1

Page: 9 of 14

Round Pole Motion Sensor

The Selux outdoor rated sensor incorporates Passive Infrared (PIR) Technology for motion sensing and also includes built-in photocell. Sensor comes pre-installed in cast aluminum housing painted to match pole finish.

Series	Hand Hole Orientation	Dim Level	Photocell Feature	Voltage
MS Motion Sensor	00 0° Clockwise from Hand Hole	D0 (Off)	Y Yes	UNV (100-347VAC single phase or 208/230/480VAC phase-to-phase)
	09 90° Clockwise from Hand Hole	D1 (1V=10%)		
	18 180° Clockwise from Hand Hole	D3 (3V=30%)	N No	
	27 270° Clockwise from Hand Hole	D5 (5V=50%)		

Factory Defaults:

- Delay to Dim: 5 minutes
- Delay to Off: 1 hour
- Sensitivity: Max
- Custom Programming: Consult Factory

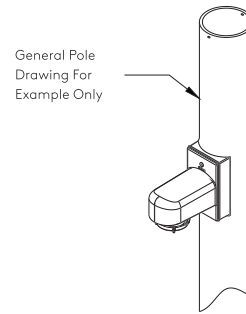
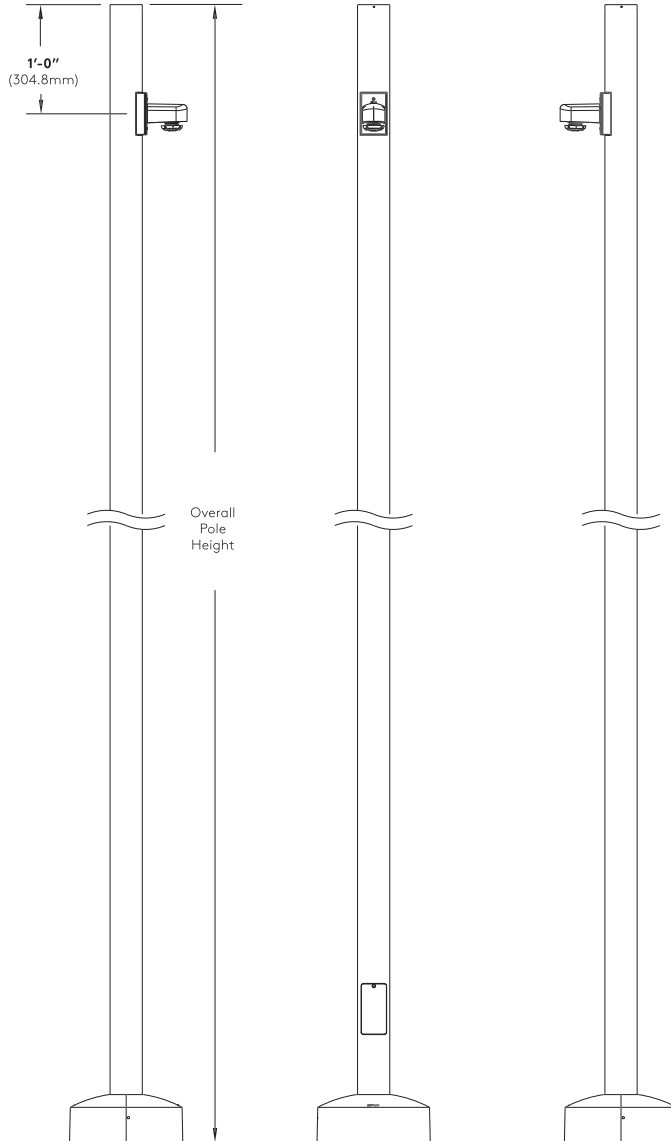

Sensor angular orientation from hand hole 0°
90° increments clockwise around pole (Type 00, 09, 18, 27)

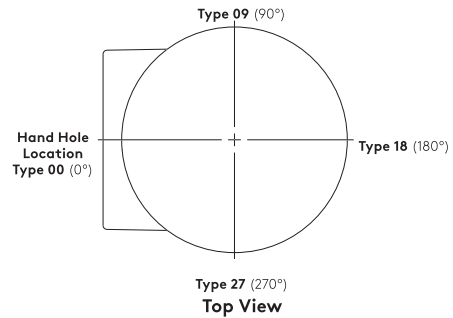

Motion Sensor Features

- Customize programming using smartphone application (Refer to the FSP-321 at www.wattstopper.com)
 - 5 Year Warranty
 - 100% Digital PIR Detection, excellent RF Immunity
 - 270° coverage pattern
 - IP66 Rated for outdoor applications
 - Made for LED light source
 - Adjustable time delays, max/min dim levels, and ramp rates
 - Suitable for Title 24 applications
- (For coverage details refer to wattstopper FSP-321 spec sheet at www.wattstopper.com)

Wiring Diagrams

Standard Wiring (120V-277V)

**When dimming is not required cap dimming wires.

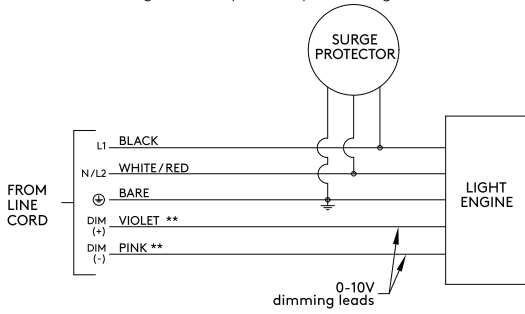

Standard Wiring (347/480V with Step-down Transformer)

**When dimming is not required cap dimming wires.

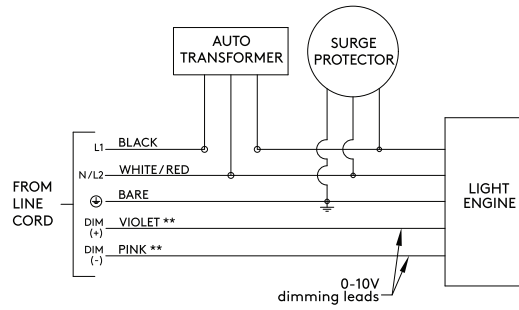

Hi-Lo Switching Option (HL) Wiring HL30 & HL50 Only

120V, 240V, 277V. When blue is energized, light output will be at "Lo" level. Specify low-level by using one of the 2 levels listed below (i.e. HL30 or HL50). For other combinations, consult factory

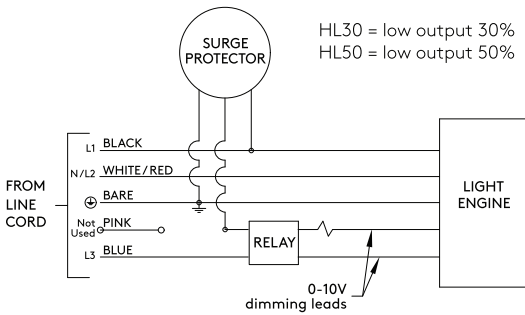

Photocell Option (TLRP) Wiring

**When dimming is not required cap dimming wires.

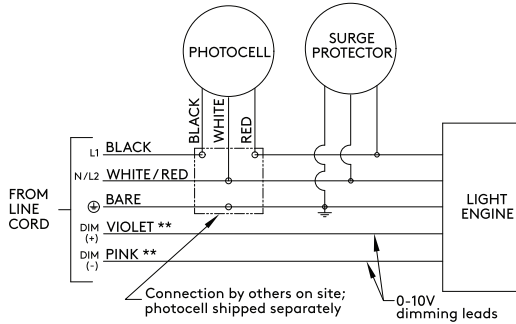

7-Pin Twist Lock Receptacle Option (TLR) Wiring

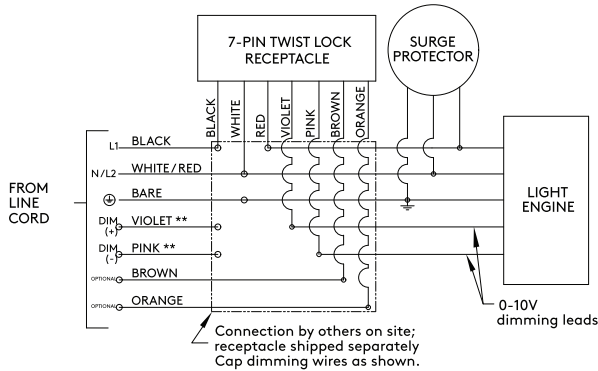

Motion Sensor Option (MS) Wiring (120-480V)

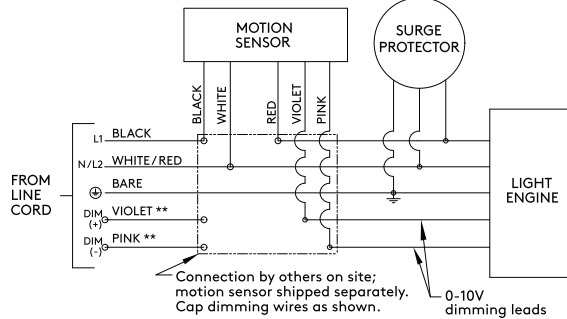

Wire Designation Table		
Source Voltage (VAC)	Wire Color	Wire Designation
120V, 277V, or 347V	Black	L1
	White	Neutral
208V, 240V, or 480V	Black	L1
	Red	L2
UNV (120V-277V)	Black	L1
	White	Neutral (120/277V) or L2 (208/240V)

Optional Accessories

TLRP,TLR, and TLRL

3-pin twist-lock receptacle with photocell, 7-pin twist-lock receptacle with shorting cap, and 7-pin twist-lock receptacle with Lutron Limelight module.

Note: TLR,TLRL and TLRP are available for all arm mounting configurations except Wall and Citalys mount (SW, LW, and C1).

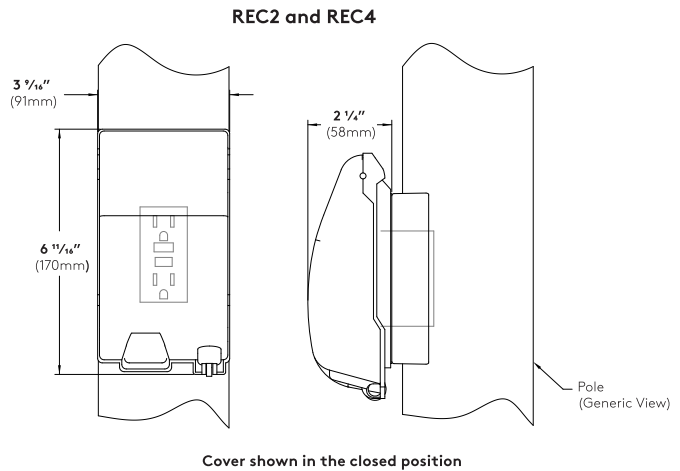
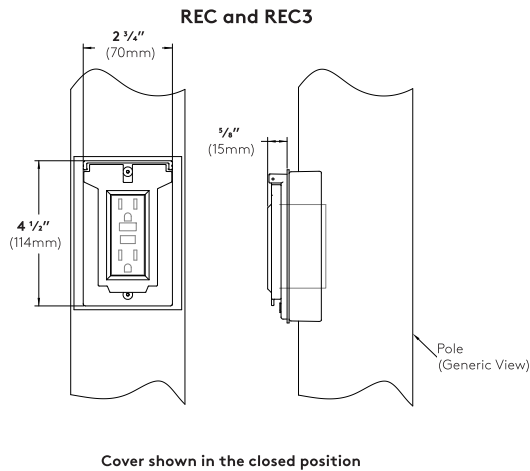
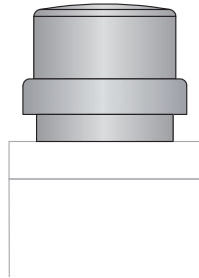

GFCI Receptacle (REC) - 120V 15A GFCI duplex receptacle with weatherproof, self-closing cover; located 36" (915mm) o.c. from base of pole, in-line with hand hole. Receptacle is intended only for portable tools or other portable equipment to be connected to outlet only when attended by operating personnel (120V only).

USB & Duplex Receptacle (REC3) (not shown) - 120V 20A duplex receptacle with USB combination ports. (1) type A and (1) type C high power 5A, 5V USB outlets. With weatherproof, self-closing cover; located 36" (915mm) o.c. from base of pole, in-line with hand hole. Receptacle is intended only for portable tools or other portable equipment to be connected to outlet only when attended by operating personnel.

REC3 does not incorporate GFCI (Ground Fault Circuit Interrupter) protection, and shall be powered by a GFCI protected branch circuit (by others).

GFCI Receptacle (REC2) - 120V 15A GFCI duplex receptacle with weatherproof, self-closing, padlockable in-use cover; located 36" (915mm) o.c. from base of pole, in-line with hand hole. Receptacle is intended only for portable tools or other portable equipment to be connected to outlet only when attended by operating personnel (120V only).

USB & Duplex Receptacle (REC4) (not shown) - 120V 20A duplex receptacle with USB combination ports. (1) type A and (1) type C high power 5A, 5V USB outlets. With weatherproof, self-closing padlockable in-use cover; located 36" (915mm) o.c. from base of pole, in-line with hand hole. Receptacle is intended only for portable tools or other portable equipment to be connected to outlet only when attended by operating personnel.

REC4 does not incorporate GFCI (Ground Fault Circuit Interrupter) protection, and shall be powered by a GFCI protected branch circuit (by others).

Photometry



R1 - Gen5 Distribution Type I/II					
Light Engine	Lumens	CCT	Input Watts	lm/W	
5G350	3,357	3000K	32	105	
5G530	4,875	3000K	47	104	
5G700	6,325	3000K	62	102	
5G900	7,548	3000K	78	97	



R2 - Gen5 Distribution Type II					
Light Engine	Lumens	CCT	Input Watts	lm/W	
5G350	3,355	3000K	32	105	
5G530	4,854	3000K	47	103	
5G700	6,321	3000K	62	102	
5G900	7,543	3000K	78	97	



R3 - Gen5 Distribution Type III					
Light Engine	Lumens	CCT	Input Watts	lm/W	
5G350	3,533	3000K	32	110	
5G530	4,875	3000K	47	104	
5G700	6,657	3000K	62	107	
5G900	7,943	3000K	78	102	



R3W - Gen5 Distribution Type III (Wide)					
Light Engine	Lumens	CCT	Input Watts	lm/W	
5G350	3,409	3000K	32	107	
5G530	4,932	3000K	47	105	
5G700	6,423	3000K	62	104	
5G900	7,664	3000K	78	98	



R4 - Gen5 Distribution Type III/IV					
Light Engine	Lumens	CCT	Input Watts	lm/W	
5G350	3,342	3000K	32	104	
5G530	4,835	3000K	47	103	
5G700	6,297	3000K	62	102	
5G900	7,513	3000K	78	96	



R5R - Gen5 Distribution Type V (Round)					
Light Engine	Lumens	CCT	Input Watts	lm/W	
5G350	3,624	3000K	32	113	
5G530	5,243	3000K	47	112	
5G700	6,297	3000K	62	102	
5G900	7,513	3000K	78	96	



DG - Diffuse Glass Distribution Type V (Round)					
Light Engine	Lumens	CCT	Input Watts	lm/W	
MP350	3,399	3000K	33	103	
MP530	4,944	3000K	48	103	
MP700	6,283	3000K	61	103	
MP900	7,943	3000K	77	103	



Catalog Information: LUMINAIRE: DSC4L-R1-S1-5G350-35-[POWER CORD]-[FINISH]-UNV
POLE: A35-14-[FINISH]-T35

Date:01/27/2023
Fixture Type:

P1

Photometry

CCT Multiplier	
2700K	0.962
3000K	1.000
3500K	1.000
4000K	1.063
5000K	1.070

TM-21 Lifetime Calculation					
Light Engine ²	Ambient Temp (°C)	Lumen Maintenance (% at hours)			Reported L ₉₀ ¹
		25K	50K	60K	
5G350	25°C	99.8%	99.8%	99.8%	L ₉₀ (12K) > 70,000 hours
	40°C	99.8%	99.8%	99.8%	L ₉₀ (12K) > 70,000 hours
5G530	25°C	99.8%	99.8%	99.8%	L ₉₀ (12K) > 70,000 hours
	40°C	99.1%	98.5%	98.0%	L ₉₀ (12K) > 73,000 hours
5G700	25°C	99.8%	99.8%	99.8%	L ₉₀ (12K) > 70,000 hours
	40°C	99.1%	98.5%	98.0%	L ₉₀ (12K) > 73,000 hours
5G900	25°C	99.1%	98.5%	98.0%	L ₉₀ (12K) > 73,000 hours
	40°C	96.6%	95.0%	93.8%	L ₉₀ (12K) > 73,000 hours

¹ Calculated in accordance with IESNA TM-21-11, projected values are within six times (6x) the IESNA LM-80-08 test duration
² Thermal measurements based on Order Code: DSC4L-R4-xx-5Gxxx-30-xx-SV-xx-UNV

TM-21 Lifetime Calculation						
Light Engine ²	Ambient Temp (°C)	Lumen Maintenance (% at hours)				Reported L ₇₀ ¹
		25K	50K	75K	90K	
MP350	25°C	97.4%	94.5%	91.8%	90.2%	L ₇₀ (15K) > 90,000 hours
	40°C	96.0%	92.2%	88.5%	86.4%	L ₇₀ (15K) > 90,000 hours
MP530	25°C	96.3%	92.8%	89.4%	87.5%	L ₇₀ (15K) > 90,000 hours
	40°C	94.9%	90.1%	85.5%	82.9%	L ₇₀ (15K) > 90,000 hours
MP700	25°C	95.2%	90.8%	86.5%	84.0%	L ₇₀ (15K) > 90,000 hours
	40°C	92.7%	85.3%	78.6%	74.8%	L ₇₀ (15K) > 90,000 hours
MP900	25°C	93.1%	86.1%	79.6%	76.0%	L ₇₀ (15K) > 90,000 hours
	40°C	83.1%	68.6%	56.7%	50.5%	L ₇₀ (15K) > 47,000 hours

¹ Calculated in accordance with IESNA TM-21-11, projected values are within six times (6x) the IESNA LM-80-08 test duration
² Thermal measurements based on Order Code: DSC4L-DG-X-MPxxx-30-XX-BL-UNV



Catalog Information:

LUMINAIRE: DSC4L-R1-S1-5G350-35-[POWER CORD]-[FINISH]-UNV

POLE: A35-14-[FINISH]-T35

Date:01/27/2023
 Fixture Type:

P1

Date: _____ Customer: _____

Project: _____

Type: _____ Qty: _____



Discera 4



Order Code: DSC4L - - - - -

Pole Order Code: _____ * See pages 8 and 9

<u>DSC4L</u>	Series	DSC4L Discera 4										
	Optics	R1 Type I	R2 Type II	R3 Type III	R3W Type III (Wide)	R4 Type IV	R5R Type V (Round)	DG Diffuse Flat Glass				
	Mounting	S1 Single Short Arm Mount	S2 Double Short Arm (180° Mount	L1 Single Long Arm Mount	L2 Double Long Arm Mount (180°)	SW Short Arm Wall Mount	LW Long Arm Wall Mount	LG1 Single Long Arm Mount with Gusset	LG2 Double Long Arm Mount with Gusset (180°)	LGW Long Arm Wall Mount with Gusset	C1 Catalys Arm Mount	* See page 8 and 9 for available poles and options. AT524 pole only available for C1 mounting.
	Comfort Light Engine (DG)	MP350 nominal 33W/2965lm	MP530 nominal 48W/4443lm	MP700 nominal 61W/5613lm	MP900 nominal 79W/6951lm	* Based on 3000K CCT * Wattage based on ac input, 347/480V are 8.3% higher						
	Technical Light Engine (R1-R5R)	5G350 nominal 32W/3357lm	5G530 nominal 47W/4875lm	5G700 nominal 62W/6325lm	5G900 nominal 78W/7548lm	* Based on R1 optics and 3000K CCT * Wattage based on ac input, 347/480V are 8.3% higher						
	CCT	27 ¹ 2700K	30 ¹ 3000K	35 3500K	40 4000K	50 5000K	¹ 2700K and 3000K IDA Approved * Consult factory for lead time					
	Power Cord Length	12 12'	15 15'	18 18'	20 20'	25 25'	XX ² XX'	² Add length of arm and height of pole to determine power cord length.				
	Finish	WH White	BL Semi-Matte Black	BK Black	BZ Bronze	SV Silver	SP Specify Premium Color					
	Voltage	UNV 120-277V	120 120V	240 240V	277 277V	347 ³ 347V	480 ³ 480V	³ Step down transformer provided. 5G900 and MP900 not available at 480V.				
	Options	DM ⁴ Dimming (0-10V)	HL30 ^{4,6} Hi-Lo Switching Low Output 30%	HL50 ^{4,5} Hi-Lo Switching Low Output 50%	HS ⁶ House Side Shield (180°)	TLR ^{5,7} 7-pin NEMA socket with shorting cap	TLRP ^{5,7} Twist Lock Receptacle 3-Pin with Photocell	TLRLL ^{5,7} Twist Lock Receptacle 7-Pin with Lutron Limelight Sensor	⁴ 120V, 240V, 277V only ⁵ DM, HLXX, TLR, TLRLL or MS only. Cannot be combined. TLRP or MS only. Cannot be combined. ⁶ Type I, II, III and IV only ⁷ Not available with wall or catalys mountings.			



Selux Corporation © 2022, T 845-834-1400, 800-735-8927, F 845-834-1401, www.selux.us
In a continuing effort to offer the best product possible, we reserve the right to change, without notice, specifications or materials that in our opinion will not alter the function of the product. Specification sheets found at www.selux.us are the most recent versions and supercede all other printed or electronic versions.

Page 1 of 14
(Rev. 04/2022)
DSC4L_SS_v3.0



Catalog Information: LUMINAIRE: DSC4L-R3W-S1-5G350-35-[POWER CORD]-[FINISH]-UNV
POLE: A35-14-[FINISH]-T35

Date: 01/27/2023
Fixture Type:

P1A

Page: 1 of 14

DSC4L

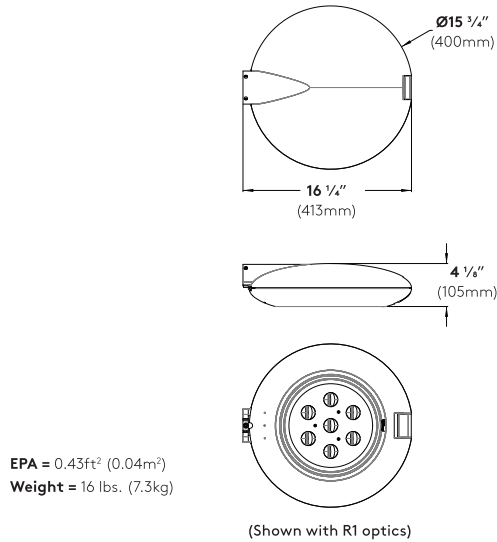

Specifications

Fixture Housing - Made from high pressure die cast, low copper aluminum alloy.

Gasketing - Continuous silicone gasket provides weatherproofing, dust and insect control at all luminaire connections.

LED Array - LEDs mounted to PC boards and attached to aluminum heat sink for maximum LED performance and life. CCT tolerance 3-step binning for 2700K, 3000K, 3500K, 4000K, and 5000K. CRI minimum 80. Complete light engine can be removed easily for future upgrade.

LED Optics - Technical Optics (R1, R2, R3, R3W, R4, and R5R) use Selux signature light pattern acrylic lens holder to secure proprietary silicone optics. Internal micro house side shield available for distributions types I, II, III & IV. Comfort Optics (DG) use mid-power LEDs and highly diffuse dish for uniformity and glare control.

LED Driver - LEDs are driven by RoHS compliant constant current programmable LED driver. Driver includes 0-10V dimming to 10%, meets the requirements of IP65. Driver assembly located inside the head.

Glass Lens - Tempered glass lens protects and seals optical chamber to IP65.

Toolless Latch - Toolless stainless steel latch for easy access to light engine.

Access Door - Lower casting features a stainless steel hinge that attaches to upper casting on mounting arm side. Other side is secured with toolless latch for ease of maintenance.

Surge Protection - Designed to protect luminaire from electrical surge (20kA).

Exterior Luminaire Finish - Selux utilizes a high quality Polyester Powder Coating. All Selux luminaires and poles are finished in our Tiger Drylac certified facility and undergo a five stage intensive pretreatment process where product is thoroughly cleaned, phosphated and sealed. Selux powder coated products provide excellent salt and humidity resistance as well as ultra violet resistance for color retention. All products are tested in accordance with test specifications for coatings from ASTM and PCI.

Standard exterior colors are White (WH), Black (BK), Semi-Matte Black (BL), Bronze (BZ), and Silver (SV). Selux premium colors (SP) are available, please specify from your Selux color selection guide.

5 Year Limited LED Luminaire Warranty - Selux offers a 5 Year Limited Warranty to the original purchaser that the Selux LED luminaire shall be free from defects in material and workmanship for up to five (5) years from date of shipment. This limited warranty covers the fixture, LED driver, and LED light engine when installed and operated according to Selux instructions. Fixture suitable for ambient temperatures between -40°C (-40°F) and 40°C (104°F). For details and exclusions, see "Selux Terms and Condition of Sale."

Listings and Ratings: Luminaire and LEDs tested to IP65, IK09, and IESNA LM-79-08 standards. LEDs tested to LM-80 standards.

Visit selux.us for our LED End of Life recycling policy.

For Buy American compliance on poles, please consult the factory.

Mounting

SW Short Arm Wall
 EPA = 0.39ft² (0.04m²)
 Weight = 23 lbs. (10kg)

S1 Single Short Arm
 EPA = 0.47ft² (0.05m²)
 Weight = 23 lbs. (10kg)

S2 Double Short Arm
 EPA = 1.05ft² (0.10m²)
 Weight = 46 lbs. (21kg)

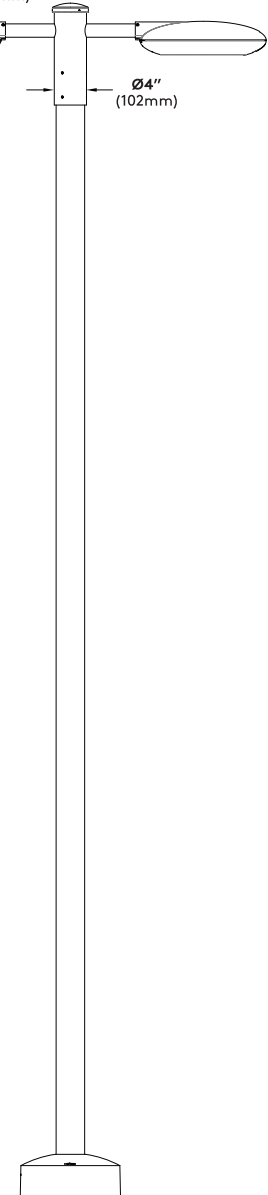
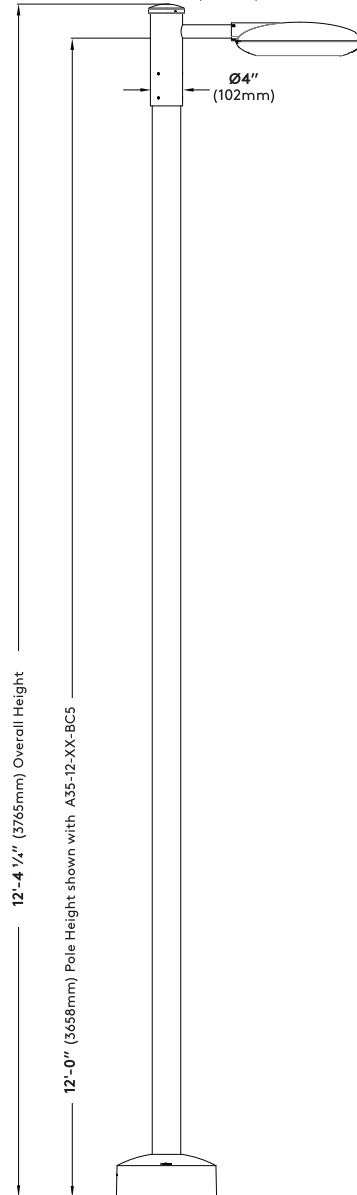
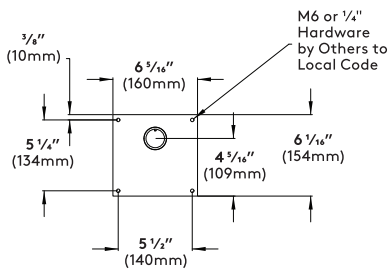
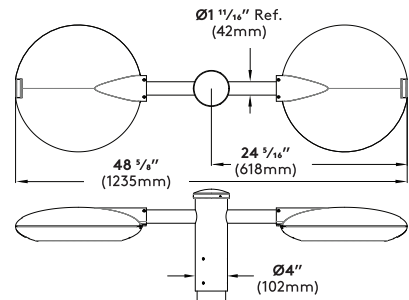
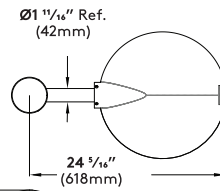
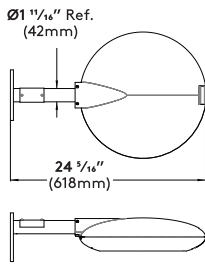

Mounting

LW Long Wall Mount
 EPA = 0.46ft² (0.05m²)
 Weight = 23 lbs. (10kg)

L1 Single Long Arm
 EPA = 0.83ft² (0.08m²)
 Weight = 52 lbs. (23.6kg)

L2 Double Long Arm
 EPA = 1.32ft² (0.13m²)
 Weight = 69.7 lbs. (31.7kg)

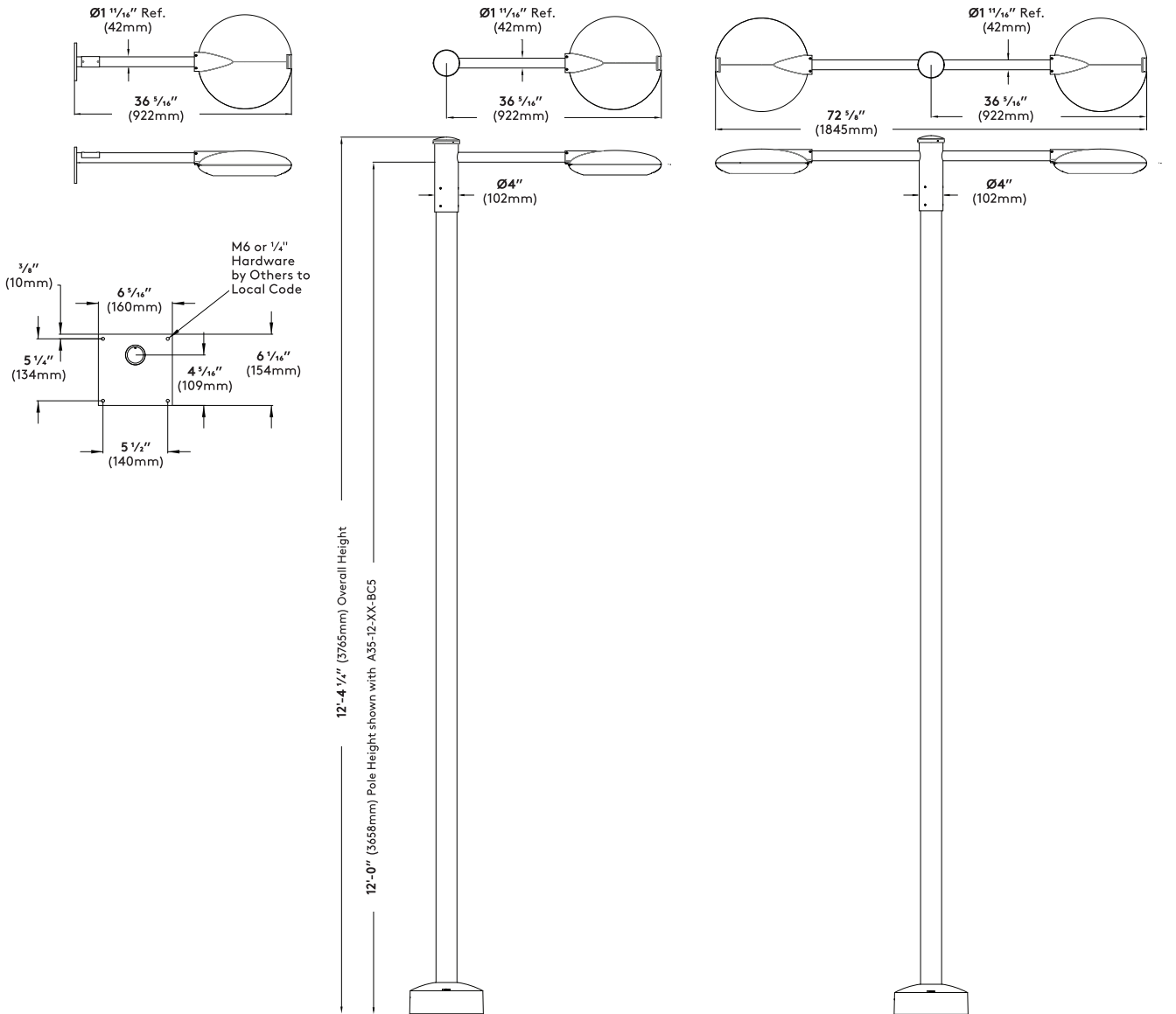

Catalog
 Information:

LUMINAIRE: DSC4L-R3W-S1-5G350-35-[POWER
 CORD]-[FINISH]-UNV

POLE: A35-14-[FINISH]-T35

Date:01/27/2023
 Fixture Type:

P1A

LGW Long Wall Mount with gusset
 EPA = 0.66ft² (0.06m²)
 Weight = 23.5 lbs. (10.7kg)

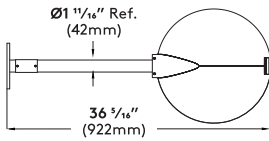

LG1 Single Long Arm with gusset
 EPA = 1.03ft² (0.10m²)
 Weight = 52.5 lbs. (23.8kg)

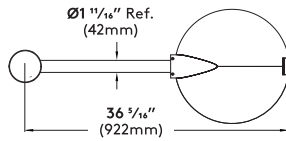

LG2 Double Long Arm with gusset
 EPA = 1.72ft² (0.13m²)
 Weight = 70.7 lbs. (32.1kg)

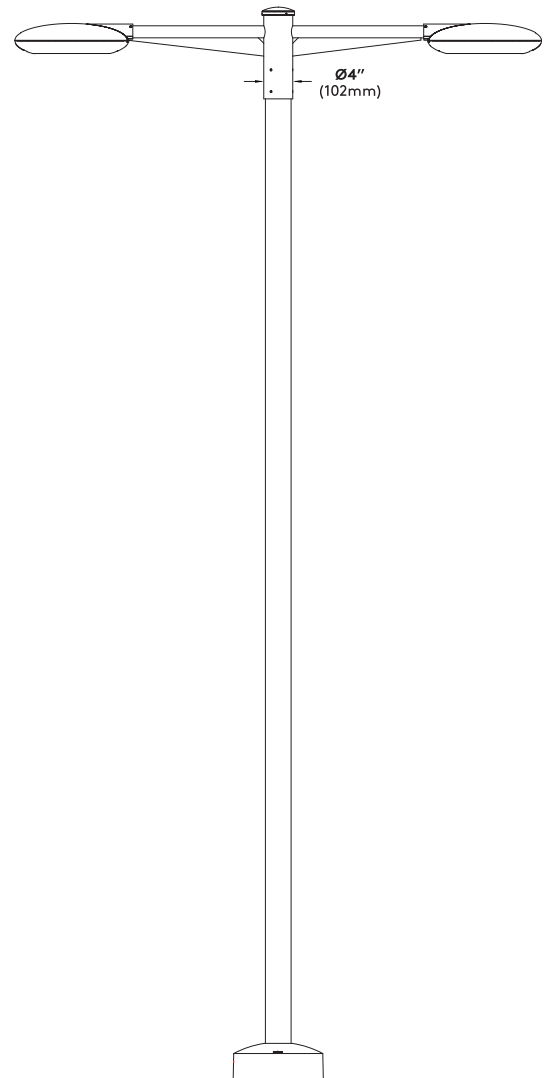
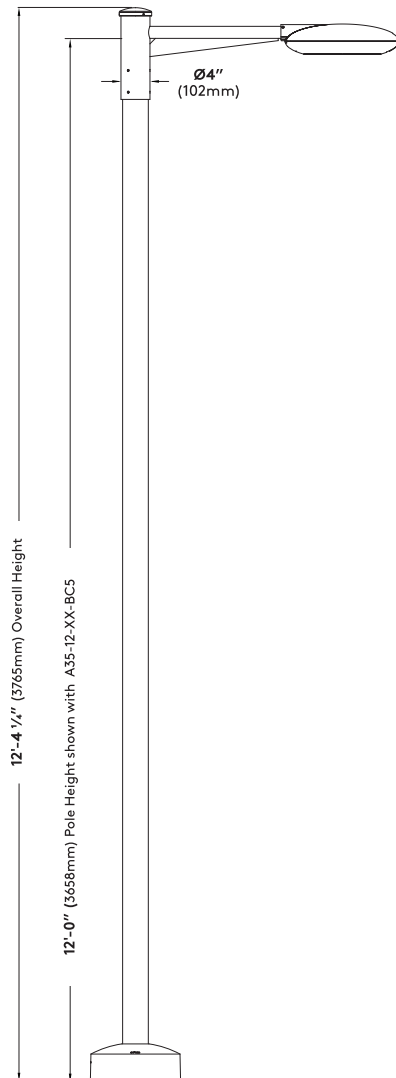
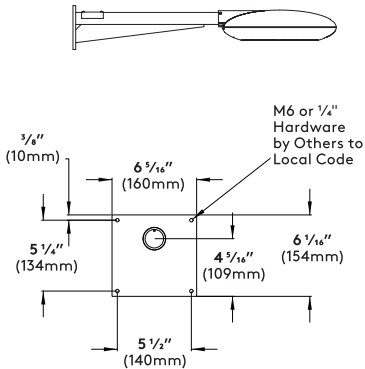
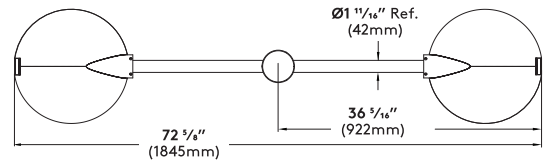

Catalog
 Information:

LUMINAIRE: DSC4L-R3W-S1-5G350-35-[POWER
 CORD]-[FINISH]-UNV

POLE: A35-14-[FINISH]-T35

Date:01/27/2023
 Fixture Type:

P1A

C1 Single Citalys Arm
EPA = .73ft²

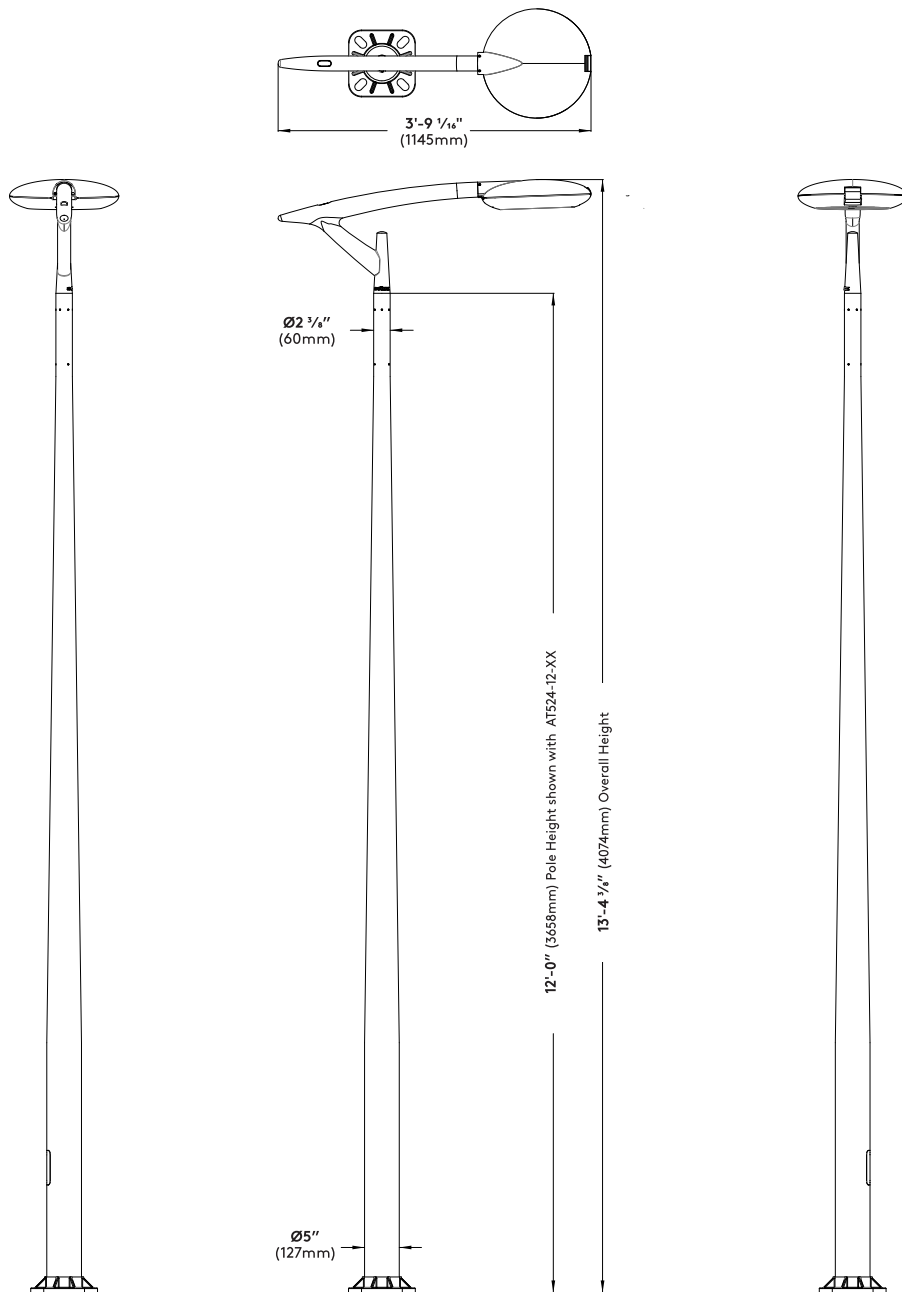

Pole Information

Refer to pole specification sheets for construction details, anchorage information and additional options.

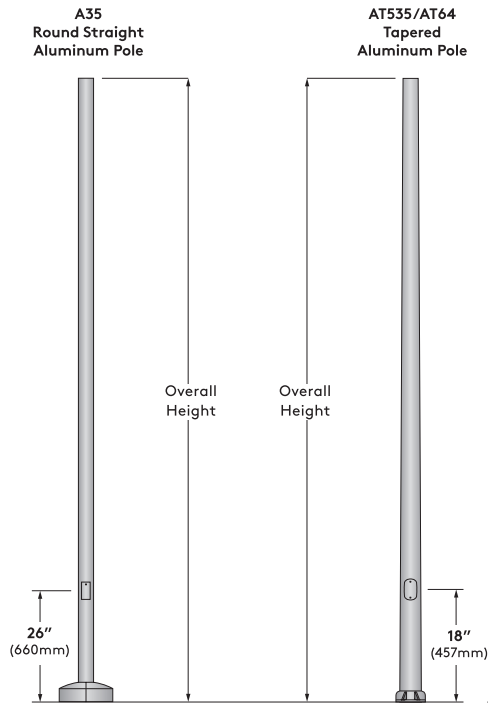

Bolt Circle for A35

Use caution when setting anchor bolts. Bolts must be vertically straight and centered on dimensions shown.

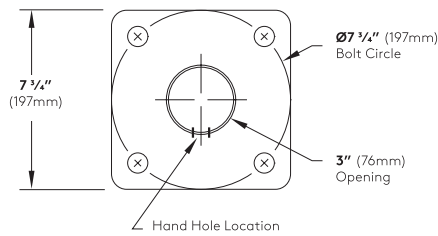

Note: Adequate drainage must be provided in concrete foundation or grout.

Optional Base Covers for Poles

Die cast aluminum, one or two-piece field installable base covers.

BC5 Standard Base Cover (A35)

Die cast aluminum, two-piece field installable base cover.

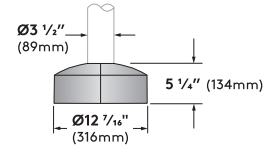

BC9 Optional Base Cover (AT64)

Die cast aluminum, two-piece field installable base cover.

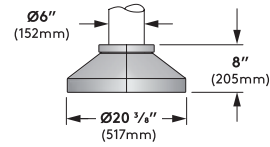

BC3 Optional Base Cover (AT535)

Die cast aluminum, two-piece field installable base cover.

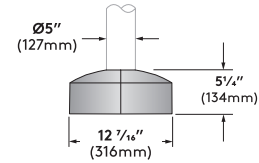

Bolt Circle for AT535

Use caution when setting anchor bolts. Bolts must be vertically straight and centered on dimensions shown.

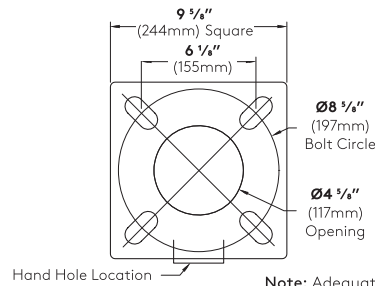

Note: Adequate drainage must be provided in concrete foundation or grout.

Bolt Circle for AT64

Use caution when setting anchor bolts. Bolts must be vertically straight and centered on dimensions shown

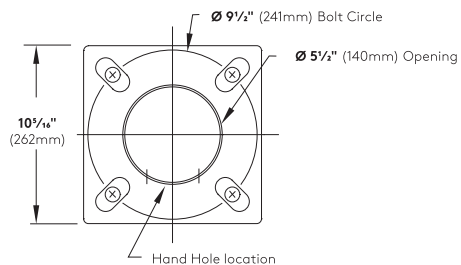

Note: Adequate drainage must be provided in concrete foundation or grout.

Pole Data Chart

Pole Series	Bolt Circle	EPA Information (ft2)											Pole Height	Finish	Options
		85 mph	90 mph	100 mph	110 mph	120 mph	130 mph	140 mph	150 mph	160 mph	170 mph	180 mph			
A35 3 1/2" Round Straight Aluminum Pole	7-3/4"	7.4	6.4	4.9	3.8	2.9	2.2	1.8	1.5	1.2	1.0	0.9	10 10ft	WH White	BC3 Decorative Cast Aluminum Base Cover (AT535 poles only)
A35 3 1/2" Round Straight Aluminum Pole	7-3/4"	5.6	4.8	3.5	2.6	1.8	1.3	0.9	0.7	0.6	-	-	12 12ft	BK Black	BC5 Decorative Cast Aluminum Base Cover (A35 pole only)
AT535 5" to 3 1/2" Round Tapered Aluminum Pole	8-5/8"	15.2	13.4	10.5	8.4	6.9	5.8	4.9	4.2	3.6	3.2	2.8	12 12ft	BL Semi-Matte Black	BC9 Decorative Cast Aluminum Base Cover (AT64 poles only)
A35 3 1/2" Round Straight Aluminum Pole	7-3/4"	4.2	3.5	2.4	1.6	1.0	0.5	-	-	-	-	-	14 14ft	BZ Bronze	REC GFCI Receptacle with weatherproof cover
AT535 5" to 3 1/2" Round Tapered Aluminum Pole	8-5/8"	12.8	11.2	8.7	6.9	5.5	4.6	3.8	3.3	2.8	2.4	2.1	14 14ft	SV Silver	REC2 GFCI Receptacle with padlockable in-use cover
A35 3 1/2" Round Straight Aluminum Pole	7-3/4"	2.7	2.1	1.2	0.6	-	-	-	-	-	-	-	16 16ft	SP Specify Pre-mium Color	REC3 USB & Duplex Receptacle with weatherproof cover
AT535 5" to 3 1/2" Round Tapered Aluminum Pole	8-5/8"	10.5	9.1	6.9	5.4	4.3	3.4	2.9	2.4	2.0	1.7	1.5	16 16ft		REC4 USB & Duplex Receptacle with weatherproof padlockable in-use cover
AT535 5" to 3 1/2" Round Tapered Aluminum Pole	8-5/8"	10.7	9.2	7.0	5.4	4.2	3.4	2.8	2.3	2.0	1.7	1.4	18 18ft		MS* Motion Sensor with Optional Photocell (Meets Title 24 Requirements)
AT64 6" to 4" Round Tapered Aluminum Pole	9-1/2"	13.6	11.9	9.2	7.3	6.0	4.9	4.2	3.5	3.0	2.6	2.2	18 18ft		T35 3 1/2" Tenon (Required for AT64 poles for arm mounting)
AT64 6" to 4" Round Tapered Aluminum Pole	9-1/2"	11.4	9.9	7.5	5.9	4.7	3.9	3.2	2.7	2.3	1.9	1.6	20 20ft		* See page 10 to specify motion sensor details * Weatherproof cover intended for portable tools or other portable equipment connected to the outlet only when attended. For other requirements please consult factory.

Notes:

1. Maximum basic wind speed certified in accordance with AASHTO 2013 (LTS-6).
2. Values are nominal 3-s gust wind speeds in accordance with ASCE 7-05 for Allowable Stress Design (ASD) analysis.



Catalog Information:

LUMINAIRE: DSC4L-R3W-S1-5G350-35-[POWER CORD]-[FINISH]-UNV

POLE: A35-14-[FINISH]-T35

Date:01/27/2023
Fixture Type:

P1A

Pole Information

Refer to pole specification sheets for construction details, anchorage information and additional options.

AT524 Tapered Aluminum Pole

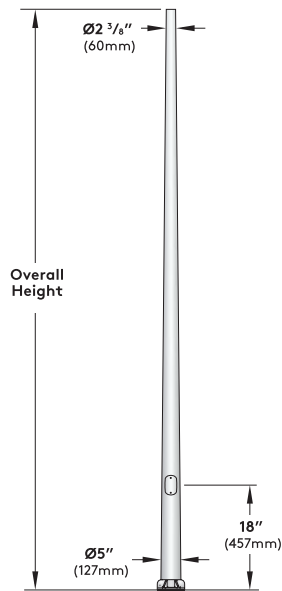

Bolt Circle

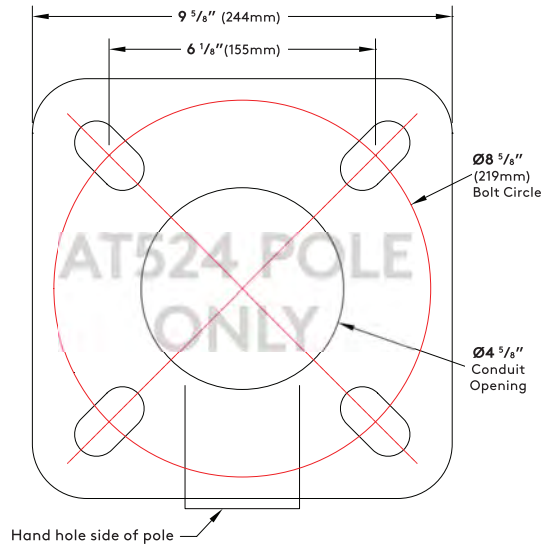

BC3 Optional Base Cover

Die cast aluminum, two piece field installable base cover

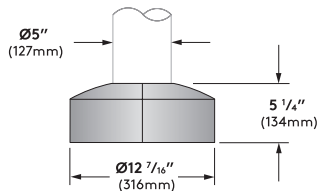

Anchor Bolt Detail

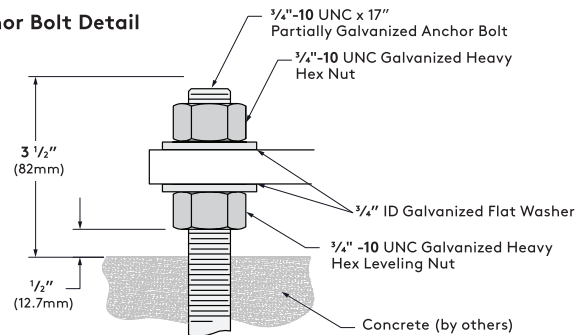

Pole Data Chart

Pole Series	Bolt Circle	Wall	EPA Information (ft ²)										Height	Finish	Options	
			85 mph	90 mph	100 mph	110 mph	120 mph	130 mph	140 mph	150 mph	160 mph	170 mph				180 mph
AT524 5" to 2.4" Round Tapered Aluminium Pole	8 5/8"	.188"	12.6	11.2	9.0	7.4	6.1	5.2	4.4	3.8	3.3	2.9	2.5	10 10ft	WH White BK Black BL Sem-Matte Black BZ Bronze SV Silver SP Specify Premium Color	BC3 Die Cast Two-Piece Aluminum decorative Base Cover REC GFCI Receptacle with weatherproof cover REC2 GFCI Receptacle with padlockable in-use cover REC3 USB & Duplex Receptacle with weatherproof cover REC4 USB & Duplex Receptacle with weatherproof padlockable in-use cover * Weatherproof cover intended for portable tools or other portable equipment connected to the outlet only when attended. For other requirements please consult factory.
			12.6	11.2	9.0	7.4	6.1	5.2	4.4	3.8	3.3	2.9	2.5	12 12ft		
			12.6	11.2	9.0	7.4	6.1	5.2	4.4	3.8	3.3	2.9	2.5	14 14ft		
			12.6	11.2	9.0	7.4	5.8	4.7	3.9	3.2	2.7	2.3	1.9	16 16ft		
			11.2	9.8	7.5	5.8	4.6	3.7	3.0	2.4	2.0	-	-	18 18ft		
			9.4	8.1	6.1	4.7	3.6	2.8	2.2	1.7	1.3	-	-	20 20ft		

Notes:

- 1) Maximum EPA ratings certified in accordance with AASHTO 2013 (LTS-6) for 3-s gust wind speeds based on Allowable Stress Design (ASD) analysis.
- 2) Consult factory for equivalent Load and Resistance Factor Design (LRFD) wind speeds.
- 3) Rated performance is dependant upon the pole being properly attached to a supporting foundation of adequate design.



Catalog Information:

LUMINAIRE: DSC4L-R3W-S1-5G350-35-[POWER CORD]-[FINISH]-UNV

POLE: A35-14-[FINISH]-T35

Date:01/27/2023

Fixture Type:

P1A

Round Pole Motion Sensor

The Selux outdoor rated sensor incorporates Passive Infrared (PIR) Technology for motion sensing and also includes built-in photocell. Sensor comes pre-installed in cast aluminum housing painted to match pole finish.

Series	Hand Hole Orientation	Dim Level	Photocell Feature	Voltage
MS Motion Sensor	00 0° Clockwise from Hand Hole	D0 (Off)	Y Yes	UNV (100-347VAC single phase or 208/230/480VAC phase-to-phase)
	09 90° Clockwise from Hand Hole	D1 (1V=10%)		
	18 180° Clockwise from Hand Hole	D3 (3V=30%)	N No	
	27 270° Clockwise from Hand Hole	D5 (5V=50%)		

Factory Defaults:

- Delay to Dim: 5 minutes
- Delay to Off: 1 hour
- Sensitivity: Max
- Custom Programming: Consult Factory

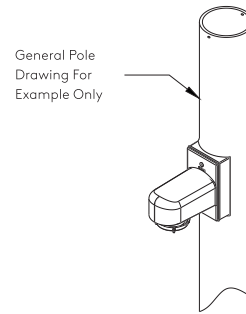
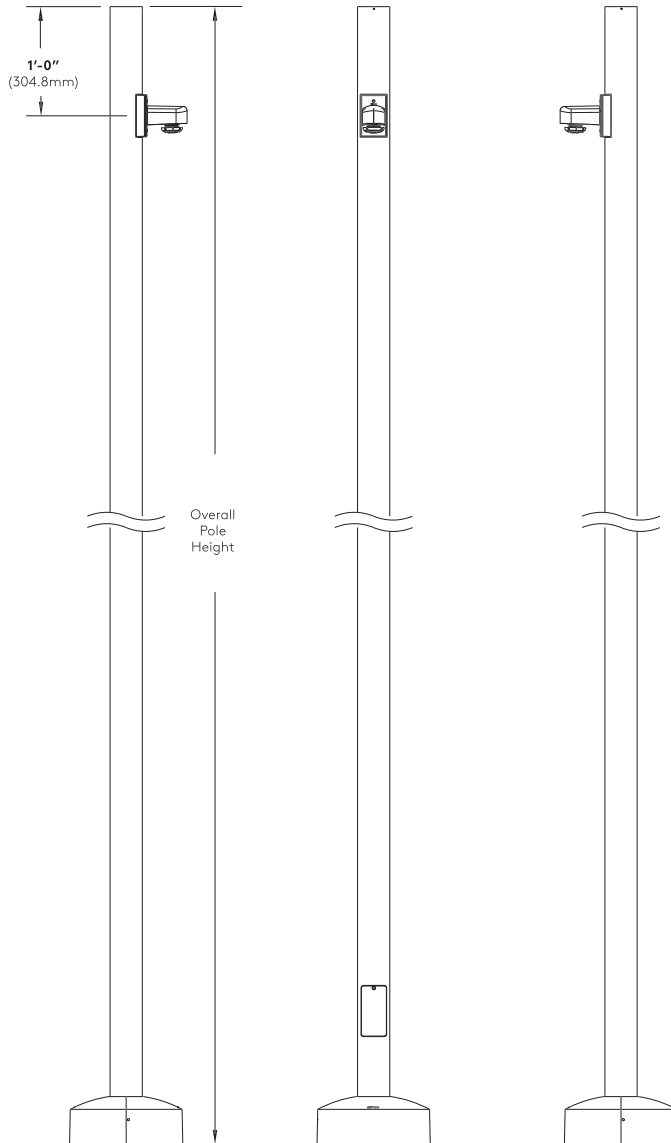

Sensor angular orientation from hand hole 0°
90° increments clockwise around pole (Type 00, 09, 18, 27)

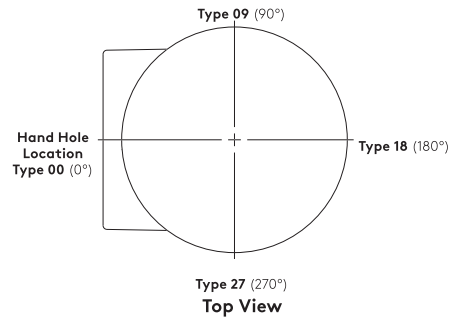

Motion Sensor Features

- Customize programming using smartphone application (Refer to the FSP-321 at www.wattstopper.com)
 - 5 Year Warranty
 - 100% Digital PIR Detection, excellent RF Immunity
 - 270° coverage pattern
 - IP66 Rated for outdoor applications
 - Made for LED light source
 - Adjustable time delays, max/min dim levels, and ramp rates
 - Suitable for Title 24 applications
- (For coverage details refer to wattstopper FSP-321 spec sheet at www.wattstopper.com)

Wiring Diagrams

Standard Wiring (120V-277V)

**When dimming is not required cap dimming wires.

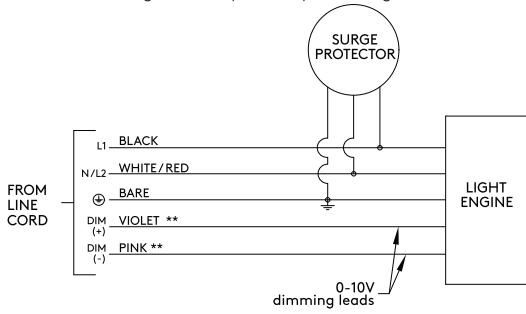

Standard Wiring (347/480V with Step-down Transformer)

**When dimming is not required cap dimming wires.

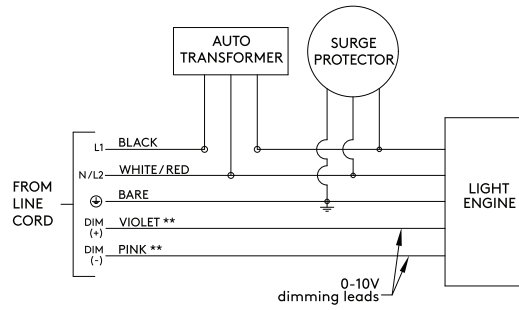

Hi-Lo Switching Option (HL) Wiring HL30 & HL50 Only

120V, 240V, 277V. When blue is energized, light output will be at "Lo" level. Specify low-level by using one of the 2 levels listed below (i.e. HL30 or HL50). For other combinations, consult factory

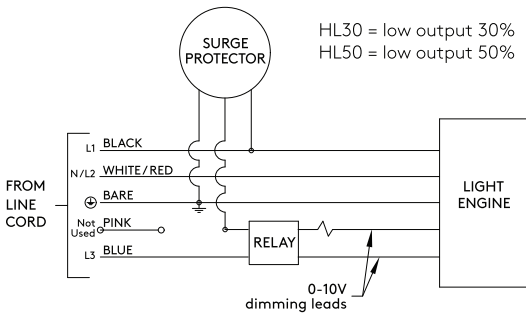

Photocell Option (TLRP) Wiring

**When dimming is not required cap dimming wires.

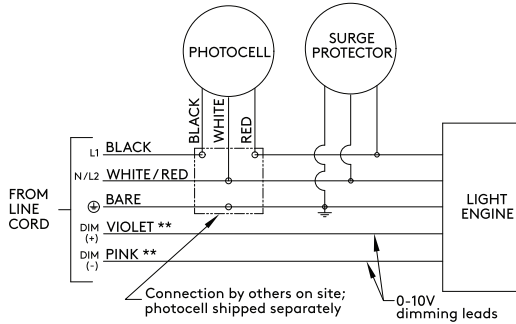

7-Pin Twist Lock Receptacle Option (TLR) Wiring

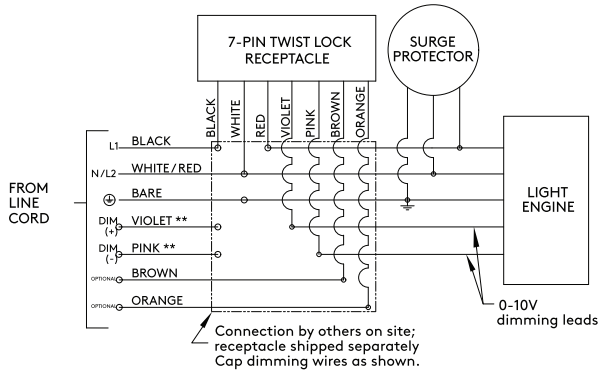

Motion Sensor Option (MS) Wiring (120-480V)

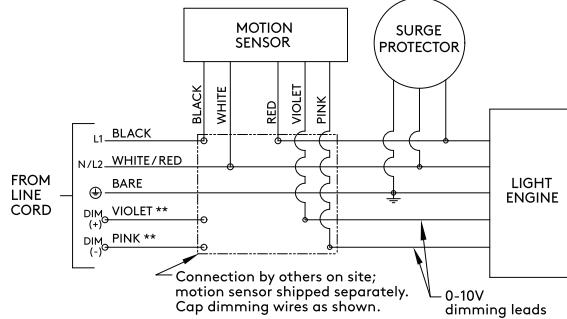

Wire Designation Table		
Source Voltage (VAC)	Wire Color	Wire Designation
120V, 277V, or 347V	Black	L1
	White	Neutral
208V, 240V, or 480V	Black	L1
	Red	L2
UNV (120V-277V)	Black	L1
	White	Neutral (120/277V) or L2 (208/240V)

Optional Accessories

TLRP,TLR, and TLRL

3-pin twist-lock receptacle with photocell, 7-pin twist-lock receptacle with shorting cap, and 7-pin twist-lock receptacle with Lutron Limelight module.

Note: TLR,TLRL and TLRP are available for all arm mounting configurations except Wall and Citalys mount (SW, LW, and C1).

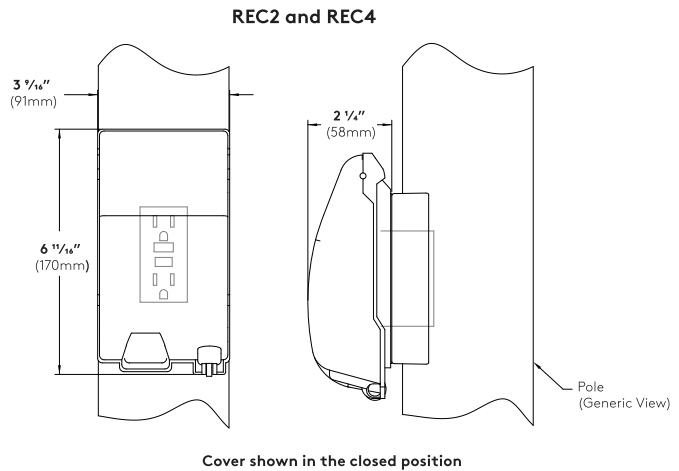
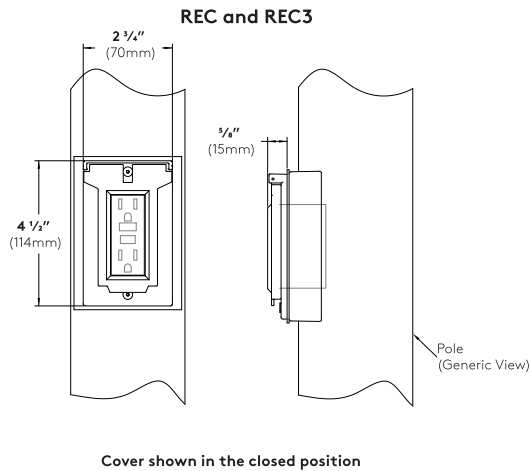
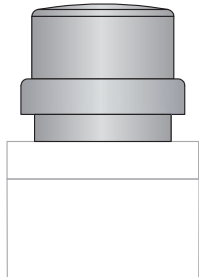

GFCI Receptacle (REC) - 120V 15A GFCI duplex receptacle with weatherproof, self-closing cover; located 36" (915mm) o.c. from base of pole, in-line with hand hole. Receptacle is intended only for portable tools or other portable equipment to be connected to outlet only when attended by operating personnel (120V only).

USB & Duplex Receptacle (REC3) (not shown) - 120V 20A duplex receptacle with USB combination ports. (1) type A and (1) type C high power 5A, 5V USB outlets. With weatherproof, self-closing cover; located 36" (915mm) o.c. from base of pole, in-line with hand hole. Receptacle is intended only for portable tools or other portable equipment to be connected to outlet only when attended by operating personnel.

REC3 does not incorporate GFCI (Ground Fault Circuit Interrupter) protection, and shall be powered by a GFCI protected branch circuit (by others).

GFCI Receptacle (REC2) - 120V 15A GFCI duplex receptacle with weatherproof, self-closing, padlockable in-use cover; located 36" (915mm) o.c. from base of pole, in-line with hand hole. Receptacle is intended only for portable tools or other portable equipment to be connected to outlet only when attended by operating personnel (120V only).

USB & Duplex Receptacle (REC4) (not shown) - 120V 20A duplex receptacle with USB combination ports. (1) type A and (1) type C high power 5A, 5V USB outlets. With weatherproof, self-closing padlockable in-use cover; located 36" (915mm) o.c. from base of pole, in-line with hand hole. Receptacle is intended only for portable tools or other portable equipment to be connected to outlet only when attended by operating personnel.

REC4 does not incorporate GFCI (Ground Fault Circuit Interrupter) protection, and shall be powered by a GFCI protected branch circuit (by others).

Photometry



R1 - Gen5 Distribution Type I/II				
Light Engine	Lumens	CCT	Input Watts	lm/W
5G350	3,357	3000K	32	105
5G530	4,875	3000K	47	104
5G700	6,325	3000K	62	102
5G900	7,548	3000K	78	97



R2 - Gen5 Distribution Type II				
Light Engine	Lumens	CCT	Input Watts	lm/W
5G350	3,355	3000K	32	105
5G530	4,854	3000K	47	103
5G700	6,321	3000K	62	102
5G900	7,543	3000K	78	97



R3 - Gen5 Distribution Type III				
Light Engine	Lumens	CCT	Input Watts	lm/W
5G350	3,533	3000K	32	110
5G530	4,875	3000K	47	104
5G700	6,657	3000K	62	107
5G900	7,943	3000K	78	102



R3W - Gen5 Distribution Type III (Wide)				
Light Engine	Lumens	CCT	Input Watts	lm/W
5G350	3,409	3000K	32	107
5G530	4,932	3000K	47	105
5G700	6,423	3000K	62	104
5G900	7,664	3000K	78	98



R4 - Gen5 Distribution Type III/IV				
Light Engine	Lumens	CCT	Input Watts	lm/W
5G350	3,342	3000K	32	104
5G530	4,835	3000K	47	103
5G700	6,297	3000K	62	102
5G900	7,513	3000K	78	96



R5R - Gen5 Distribution Type V (Round)				
Light Engine	Lumens	CCT	Input Watts	lm/W
5G350	3,624	3000K	32	113
5G530	5,243	3000K	47	112
5G700	6,297	3000K	62	102
5G900	7,513	3000K	78	96



DG - Diffuse Glass Distribution Type V (Round)				
Light Engine	Lumens	CCT	Input Watts	lm/W
MP350	3,399	3000K	33	103
MP530	4,944	3000K	48	103
MP700	6,283	3000K	61	103
MP900	7,943	3000K	77	103



Catalog Information: LUMINAIRE: DSC4L-R3W-S1-5G350-35-[POWER CORD]-[FINISH]-UNV
POLE: A35-14-[FINISH]-T35

Date:01/27/2023
Fixture Type:

P1A

Photometry

CCT Multiplier	
2700K	0.962
3000K	1.000
3500K	1.000
4000K	1.063
5000K	1.070

TM-21 Lifetime Calculation					
Light Engine ²	Ambient Temp (°C)	Lumen Maintenance (% at hours)			Reported L ₉₀ ¹
		25K	50K	60K	
5G350	25°C	99.8%	99.8%	99.8%	L ₉₀ (12K) > 70,000 hours
	40°C	99.8%	99.8%	99.8%	L ₉₀ (12K) > 70,000 hours
5G530	25°C	99.8%	99.8%	99.8%	L ₉₀ (12K) > 70,000 hours
	40°C	99.1%	98.5%	98.0%	L ₉₀ (12K) > 73,000 hours
5G700	25°C	99.8%	99.8%	99.8%	L ₉₀ (12K) > 70,000 hours
	40°C	99.1%	98.5%	98.0%	L ₉₀ (12K) > 73,000 hours
5G900	25°C	99.1%	98.5%	98.0%	L ₉₀ (12K) > 73,000 hours
	40°C	96.6%	95.0%	93.8%	L ₉₀ (12K) > 73,000 hours

¹ Calculated in accordance with IESNA TM-21-11, projected values are within six times (6x) the IESNA LM-80-08 test duration

² Thermal measurements based on Order Code: DSC4L-R4-xx-5Gxxx-30-xx-SV-xx-UNV

TM-21 Lifetime Calculation						
Light Engine ²	Ambient Temp (°C)	Lumen Maintenance (% at hours)				Reported L ₇₀ ¹
		25K	50K	75K	90K	
MP350	25°C	97.4%	94.5%	91.8%	90.2%	L ₇₀ (15K) > 90,000 hours
	40°C	96.0%	92.2%	88.5%	86.4%	L ₇₀ (15K) > 90,000 hours
MP530	25°C	96.3%	92.8%	89.4%	87.5%	L ₇₀ (15K) > 90,000 hours
	40°C	94.9%	90.1%	85.5%	82.9%	L ₇₀ (15K) > 90,000 hours
MP700	25°C	95.2%	90.8%	86.5%	84.0%	L ₇₀ (15K) > 90,000 hours
	40°C	92.7%	85.3%	78.6%	74.8%	L ₇₀ (15K) > 90,000 hours
MP900	25°C	93.1%	86.1%	79.6%	76.0%	L ₇₀ (15K) > 90,000 hours
	40°C	83.1%	68.6%	56.7%	50.5%	L ₇₀ (15K) > 47,000 hours

¹ Calculated in accordance with IESNA TM-21-11, projected values are within six times (6x) the IESNA LM-80-08 test duration

² Thermal measurements based on Order Code: DSC4L-DG-X-MPxxx-30-XX-BL-UNV



Catalog Information:

LUMINAIRE: DSC4L-R3W-S1-5G350-35-[POWER CORD]-[FINISH]-UNV

POLE: A35-14-[FINISH]-T35

Date:01/27/2023
Fixture Type:

P1A

Date: _____ Customer: _____

Project: _____

Type: _____ Qty: _____



Discera 4



Order Code: DSC4L - - - - -

Pole Order Code: _____ * See pages 8 and 9

<u>DSC4L</u>	Series	DSC4L Discera 4											
	Optics	R1 Type I	R2 Type II	R3 Type III	R3W Type III (Wide)	R4 Type IV	R5R Type V (Round)	DG Diffuse Flat Glass					
	Mounting	S1 Single Short Arm Mount	S2 Double Short Arm (180° Mount)	L1 Single Long Arm Mount	L2 Double Long Arm Mount (180°)	SW Short Arm Wall Mount	LW Long Arm Wall Mount	LG1 Single Long Arm Mount with Gusset	LG2 Double Long Arm Mount with Gusset (180°)	LGW Long Arm Wall Mount with Gusset	C1 Catalys Arm Mount	* See page 8 and 9 for available poles and options. AT524 pole only available for C1 mounting.	
	Comfort Light Engine (DG)	MP350 nominal 33W/2965lm	MP530 nominal 48W/4443lm	MP700 nominal 61W/5613lm	MP900 nominal 79W/6951lm				* Based on 3000K CCT * Wattage based on ac input, 347/480V are 8.3% higher				
	Technical Light Engine (R1-R5R)	5G350 nominal 32W/3357lm	5G530 nominal 47W/4875lm	5G700 nominal 62W/6325lm	5G900 nominal 78W/7548lm				* Based on R1 optics and 3000K CCT * Wattage based on ac input, 347/480V are 8.3% higher				
	CCT	27 ¹ 2700K	30 ¹ 3000K	35 3500K	40 4000K	50 5000K				¹ 2700K and 3000K IDA Approved * Consult factory for lead time			
	Power Cord Length	12 12'	15 15'	18 18'	20 20'	25 25'	XX ² XX'						² Add length of arm and height of pole to determine power cord length.
	Finish	WH White	BL Semi-Matte Black	BK Black	BZ Bronze	SV Silver	SP Specify Premium Color						
	Voltage	UNV 120-277V	120 120V	240 240V	277 277V	347 ³ 347V	480 ³ 480V						³ Step down transformer provided. 5G900 and MP900 not available at 480V.
	Options	DM ⁴ Dimming (0-10V)	HL30 ^{4,6} Hi-Lo Switching Low Output 30%	HL50 ^{4,5} Hi-Lo Switching Low Output 50%	HS ⁶ House Side Shield (180°)	TLR ^{5,7} 7-pin NEMA socket with shorting cap	TLRP ^{5,7} Twist Lock Receptacle 3-Pin with Photocell	TLRLL ^{5,7} Twist Lock Receptacle 7-Pin with Lutron Limelight Sensor					⁴ 120V, 240V, 277V only ⁵ DM, HLXX, TLR, TLRLL or MS only. Cannot be combined. TLRP or MS only. Cannot be combined. ⁶ Type I, II, III and IV only ⁷ Not available with wall or catalys mountings.
		BS Bird Spikes (consult factory)	MS ^{5,7} Motion Sensor with Optional Photocell (Meets Title 24 requirements)										



Selux Corporation © 2022, T 845-834-1400, 800-735-8927, F 845-834-1401, www.selux.us
In a continuing effort to offer the best product possible, we reserve the right to change, without notice, specifications or materials that in our opinion will not alter the function of the product. Specification sheets found at www.selux.us are the most recent versions and supercede all other printed or electronic versions.

Page 1 of 14
(Rev. 04/2022)
DSC4L_SS_v3.0



Catalog Information: LUMINAIRE: DSC4L-R5R-S1-5G350-35-[POWER CORD]-[FINISH]-UNV
POLE: A35-14-[FINISH]-T35

Date: 01/27/2023
Fixture Type:

P1B

Page: 1 of 14

DSC4L

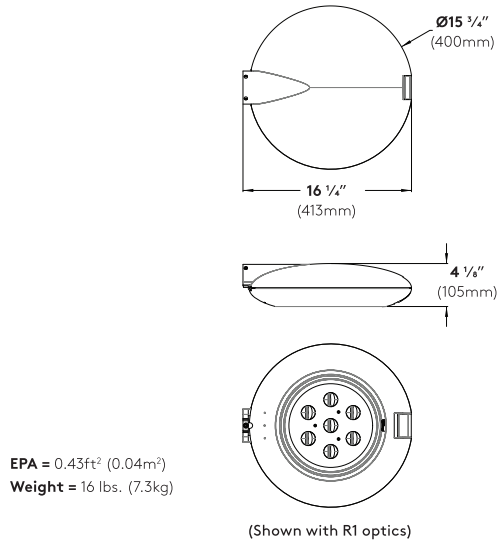

Specifications

Fixture Housing - Made from high pressure die cast, low copper aluminum alloy.

Gasketing - Continuous silicone gasket provides weatherproofing, dust and insect control at all luminaire connections.

LED Array - LEDs mounted to PC boards and attached to aluminum heat sink for maximum LED performance and life. CCT tolerance 3-step binning for 2700K, 3000K, 3500K, 4000K, and 5000K. CRI minimum 80. Complete light engine can be removed easily for future upgrade.

LED Optics - Technical Optics (R1, R2, R3, R3W, R4, and R5R) use Selux signature light pattern acrylic lens holder to secure proprietary silicone optics. Internal micro house side shield available for distributions types I, II, III & IV. Comfort Optics (DG) use mid-power LEDs and highly diffuse dish for uniformity and glare control.

LED Driver - LEDs are driven by RoHS compliant constant current programmable LED driver. Driver includes 0-10V dimming to 10%, meets the requirements of IP65. Driver assembly located inside the head.

Glass Lens - Tempered glass lens protects and seals optical chamber to IP65.

Toolless Latch - Toolless stainless steel latch for easy access to light engine.

Access Door - Lower casting features a stainless steel hinge that attaches to upper casting on mounting arm side. Other side is secured with toolless latch for ease of maintenance.

Surge Protection - Designed to protect luminaire from electrical surge (20kA).

Exterior Luminaire Finish - Selux utilizes a high quality Polyester Powder Coating. All Selux luminaires and poles are finished in our Tiger Drylac certified facility and undergo a five stage intensive pretreatment process where product is thoroughly cleaned, phosphated and sealed. Selux powder coated products provide excellent salt and humidity resistance as well as ultra violet resistance for color retention. All products are tested in accordance with test specifications for coatings from ASTM and PCI.

Standard exterior colors are White (WH), Black (BK), Semi-Matte Black (BL), Bronze (BZ), and Silver (SV). Selux premium colors (SP) are available, please specify from your Selux color selection guide.

5 Year Limited LED Luminaire Warranty - Selux offers a 5 Year Limited Warranty to the original purchaser that the Selux LED luminaire shall be free from defects in material and workmanship for up to five (5) years from date of shipment. This limited warranty covers the fixture, LED driver, and LED light engine when installed and operated according to Selux instructions. Fixture suitable for ambient temperatures between -40°C (-40°F) and 40°C (104°F). For details and exclusions, see "Selux Terms and Condition of Sale."

Listings and Ratings: Luminaire and LEDs tested to IP65, IK09, and IESNA LM-79-08 standards. LEDs tested to LM-80 standards.

Visit selux.us for our LED End of Life recycling policy.

For Buy American compliance on poles, please consult the factory.

Mounting

SW Short Arm Wall
 EPA = 0.39ft² (0.04m²)
 Weight = 23 lbs. (10kg)

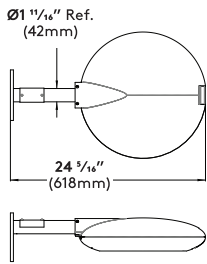

S1 Single Short Arm
 EPA = 0.47ft² (0.05m²)
 Weight = 23 lbs. (10kg)

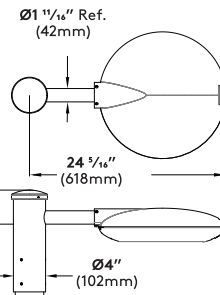

S2 Double Short Arm
 EPA = 1.05ft² (0.10m²)
 Weight = 46 lbs. (21kg)

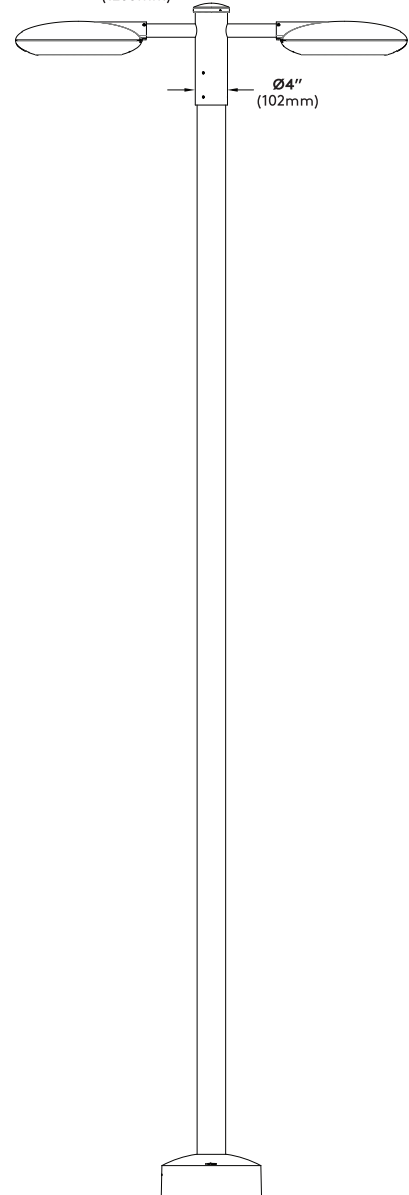
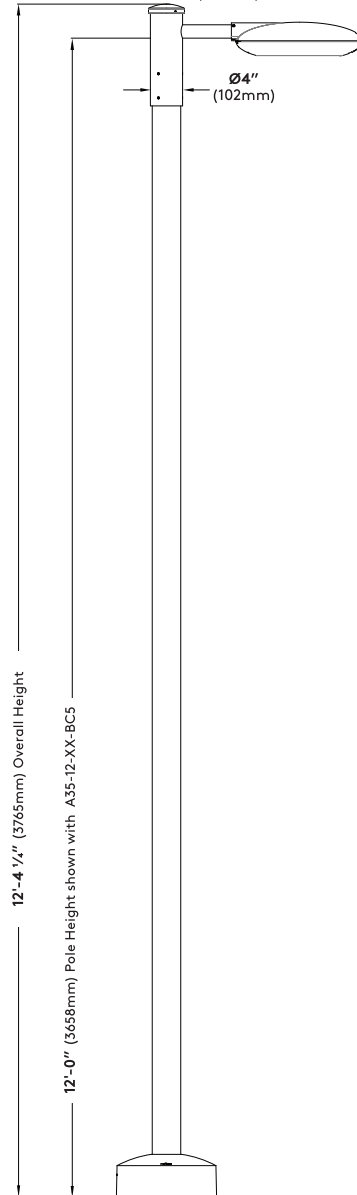
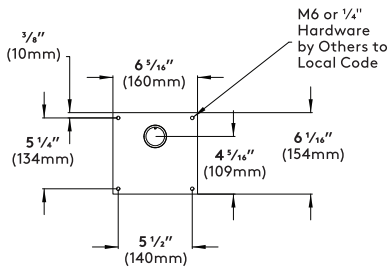
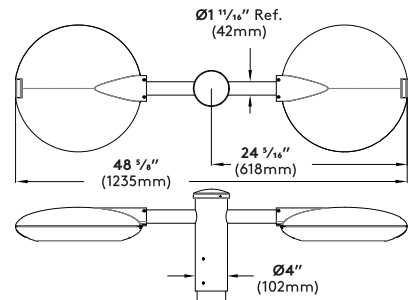

Mounting

LW Long Wall Mount
 EPA = 0.46ft² (0.05m²)
 Weight = 23 lbs. (10kg)

L1 Single Long Arm
 EPA = 0.83ft² (0.08m²)
 Weight = 52 lbs. (23.6kg)

L2 Double Long Arm
 EPA = 1.32ft² (0.13m²)
 Weight = 69.7 lbs. (31.7kg)

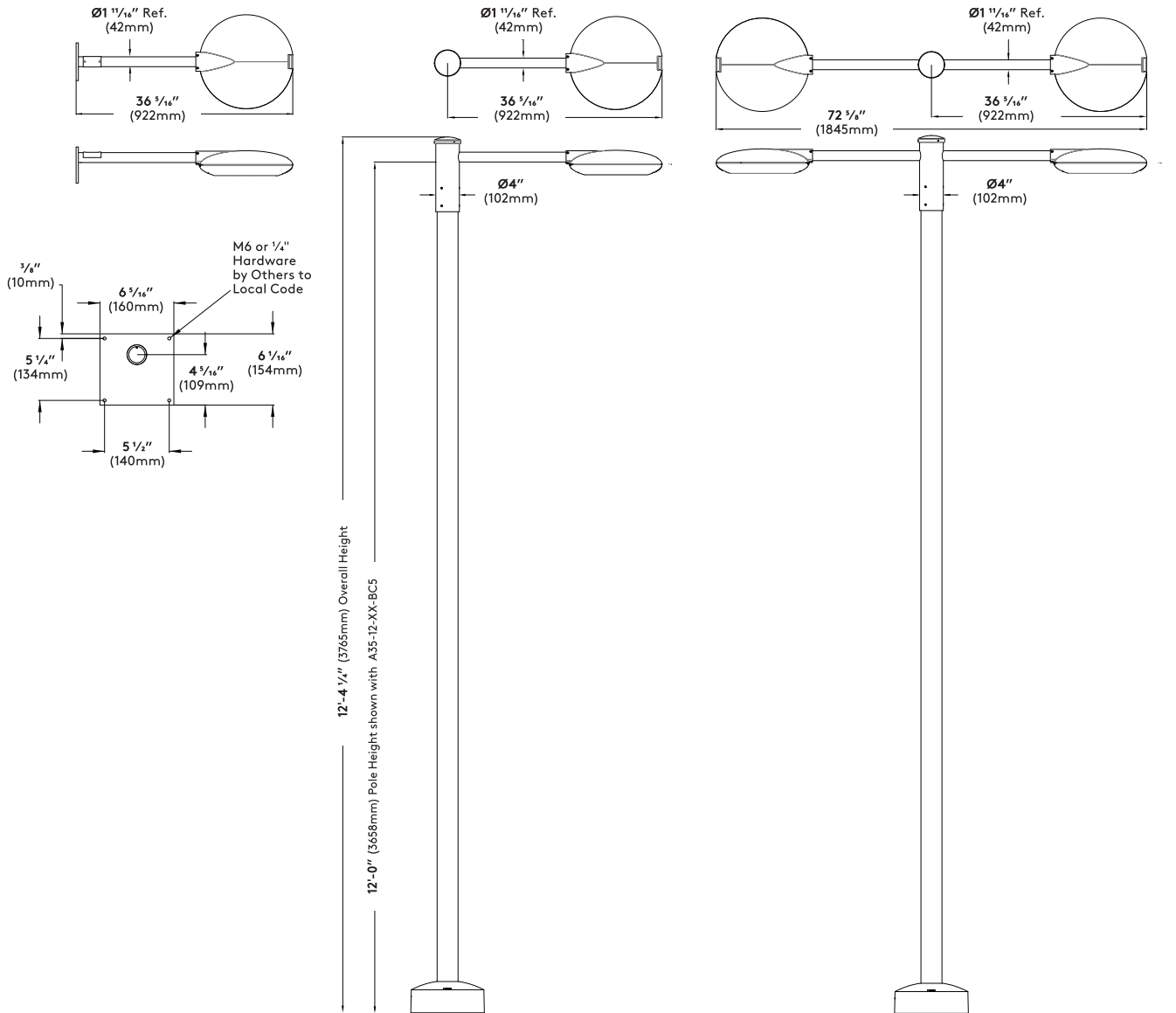

Catalog
 Information:

LUMINAIRE: DSC4L-R5R-S1-5G350-35-[POWER
 CORD]-[FINISH]-UNV

POLE: A35-14-[FINISH]-T35

Date:01/27/2023
 Fixture Type:

P1B

LGW Long Wall Mount with gusset
 EPA = 0.66ft² (0.06m²)
 Weight = 23.5 lbs. (10.7kg)

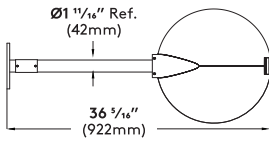

LG1 Single Long Arm with gusset
 EPA = 1.03ft² (0.10m²)
 Weight = 52.5 lbs. (23.8kg)

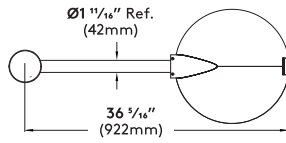

LG2 Double Long Arm with gusset
 EPA = 1.72ft² (0.13m²)
 Weight = 70.7 lbs. (32.1kg)

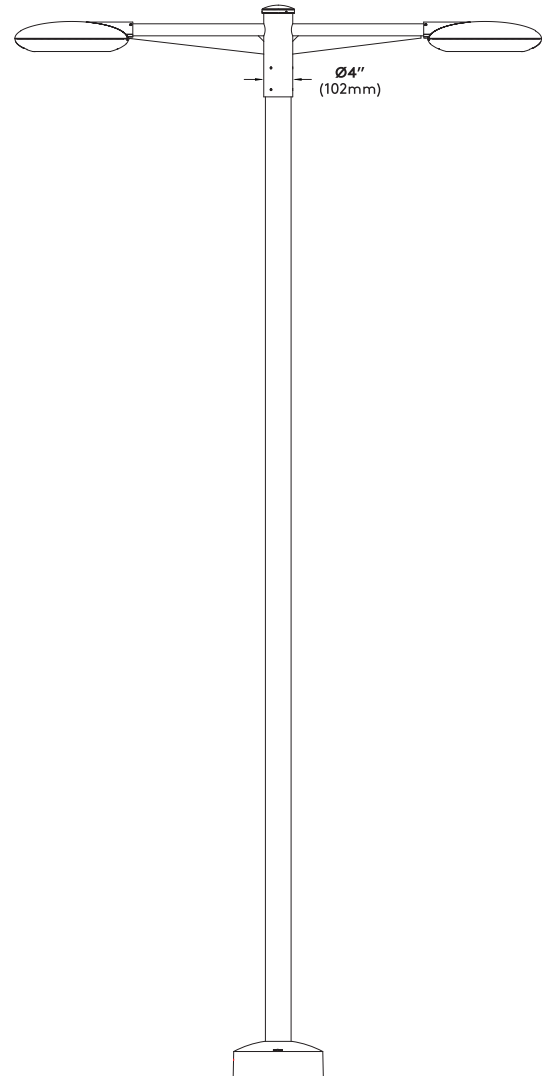
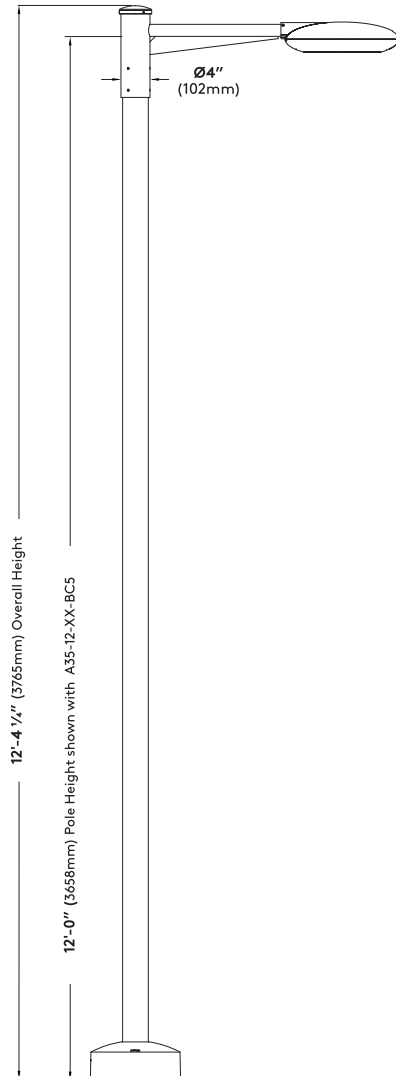
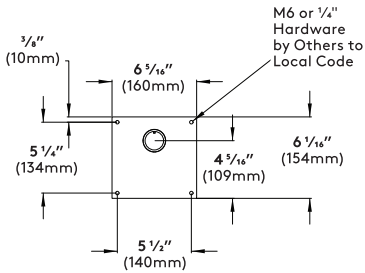
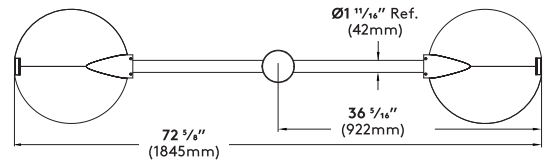

Catalog
 Information:

LUMINAIRE: DSC4L-R5R-S1-5G350-35-[POWER
 CORD]-[FINISH]-UNV

POLE: A35-14-[FINISH]-T35

Date:01/27/2023
 Fixture Type:

P1B

C1 Single Citalys Arm
EPA = .73ft²

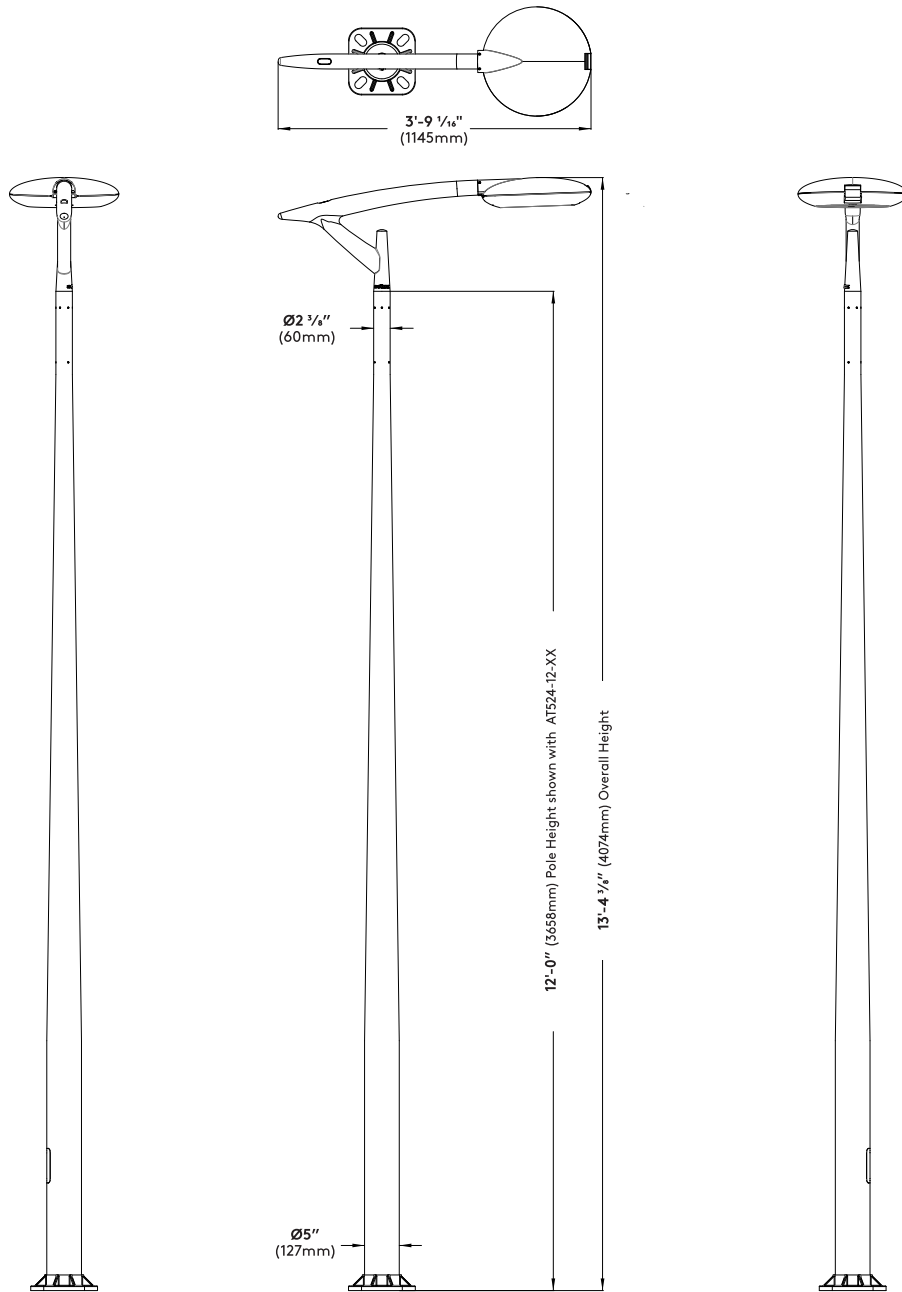

Catalog
Information:

LUMINAIRE: DSC4L-R5R-S1-5G350-35-[POWER
CORD]-[FINISH]-UNV

POLE: A35-14-[FINISH]-T35

Date:01/27/2023
Fixture Type:

P1B

Pole Information

Refer to pole specification sheets for construction details, anchorage information and additional options.

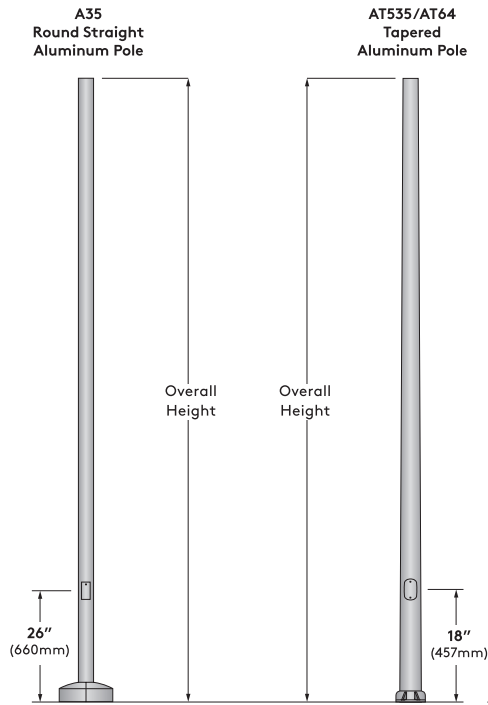

Bolt Circle for A35

Use caution when setting anchor bolts. Bolts must be vertically straight and centered on dimensions shown.

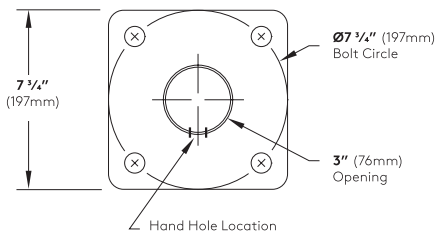

Note: Adequate drainage must be provided in concrete foundation or grout.

Optional Base Covers for Poles

Die cast aluminum, one or two-piece field installable base covers.

BC5 Standard Base Cover (A35)

Die cast aluminum, two-piece field installable base cover.

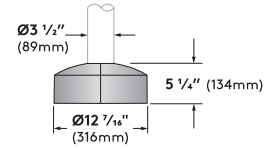

BC9 Optional Base Cover (AT64)

Die cast aluminum, two-piece field installable base cover.

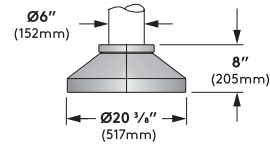

BC3 Optional Base Cover (AT535)

Die cast aluminum, two-piece field installable base cover.

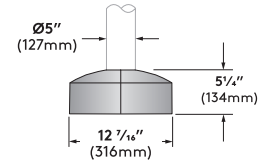

Bolt Circle for AT535

Use caution when setting anchor bolts. Bolts must be vertically straight and centered on dimensions shown.

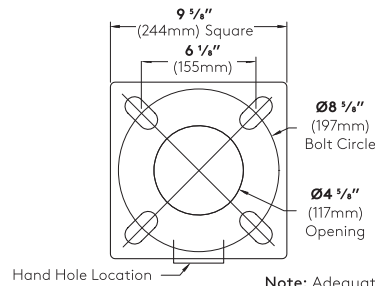

Note: Adequate drainage must be provided in concrete foundation or grout.

Bolt Circle for AT64

Use caution when setting anchor bolts. Bolts must be vertically straight and centered on dimensions shown

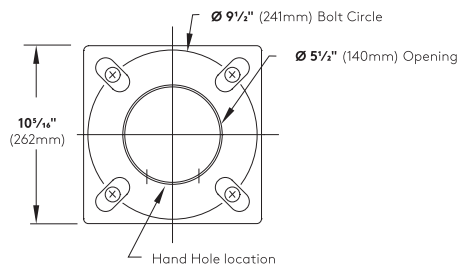

Note: Adequate drainage must be provided in concrete foundation or grout.

Pole Data Chart

Pole Series	Bolt Circle	EPA Information (ft2)											Pole Height	Finish	Options
		85 mph	90 mph	100 mph	110 mph	120 mph	130 mph	140 mph	150 mph	160 mph	170 mph	180 mph			
A35 3 1/2" Round Straight Aluminum Pole	7-3/4"	7.4	6.4	4.9	3.8	2.9	2.2	1.8	1.5	1.2	1.0	0.9	10 10ft	WH White	BC3 Decorative Cast Aluminum Base Cover (AT535 poles only)
A35 3 1/2" Round Straight Aluminum Pole	7-3/4"	5.6	4.8	3.5	2.6	1.8	1.3	0.9	0.7	0.6	-	-	12 12ft	BK Black	BC5 Decorative Cast Aluminum Base Cover (A35 pole only)
AT535 5" to 3 1/2" Round Tapered Aluminum Pole	8-5/8"	15.2	13.4	10.5	8.4	6.9	5.8	4.9	4.2	3.6	3.2	2.8	12 12ft	BL Semi-Matte Black	BC9 Decorative Cast Aluminum Base Cover (AT64 poles only)
A35 3 1/2" Round Straight Aluminum Pole	7-3/4"	4.2	3.5	2.4	1.6	1.0	0.5	-	-	-	-	-	14 14ft	BZ Bronze	REC GFCI Receptacle with weatherproof cover
AT535 5" to 3 1/2" Round Tapered Aluminum Pole	8-5/8"	12.8	11.2	8.7	6.9	5.5	4.6	3.8	3.3	2.8	2.4	2.1	14 14ft	SV Silver	REC2 GFCI Receptacle with padlockable in-use cover
A35 3 1/2" Round Straight Aluminum Pole	7-3/4"	2.7	2.1	1.2	0.6	-	-	-	-	-	-	-	16 16ft	SP Specify Pre-mium Color	REC3 USB & Duplex Receptacle with weatherproof cover
AT535 5" to 3 1/2" Round Tapered Aluminum Pole	8-5/8"	10.5	9.1	6.9	5.4	4.3	3.4	2.9	2.4	2.0	1.7	1.5	16 16ft		REC4 USB & Duplex Receptacle with weatherproof padlockable in-use cover
AT535 5" to 3 1/2" Round Tapered Aluminum Pole	8-5/8"	10.7	9.2	7.0	5.4	4.2	3.4	2.8	2.3	2.0	1.7	1.4	18 18ft		MS* Motion Sensor with Optional Photocell (Meets Title 24 Requirements)
AT64 6" to 4" Round Tapered Aluminum Pole	9-1/2"	13.6	11.9	9.2	7.3	6.0	4.9	4.2	3.5	3.0	2.6	2.2	18 18ft		T35 3 1/2" Tenon (Required for AT64 poles for arm mounting)
AT64 6" to 4" Round Tapered Aluminum Pole	9-1/2"	11.4	9.9	7.5	5.9	4.7	3.9	3.2	2.7	2.3	1.9	1.6	20 20ft		* See page 10 to specify motion sensor details * Weatherproof cover intended for portable tools or other portable equipment connected to the outlet only when attended. For other requirements please consult factory.

Notes:

1. Maximum basic wind speed certified in accordance with AASHTO 2013 (LTS-6).
2. Values are nominal 3-s gust wind speeds in accordance with ASCE 7-05 for Allowable Stress Design (ASD) analysis.



Catalog Information:

LUMINAIRE: DSC4L-R5R-S1-5G350-35-[POWER CORD]-[FINISH]-UNV

POLE: A35-14-[FINISH]-T35

Date:01/27/2023
Fixture Type:

P1B

Pole Information

Refer to pole specification sheets for construction details, anchorage information and additional options.

AT524 Tapered Aluminum Pole

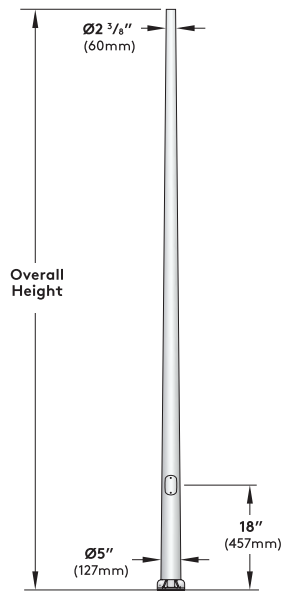

Bolt Circle

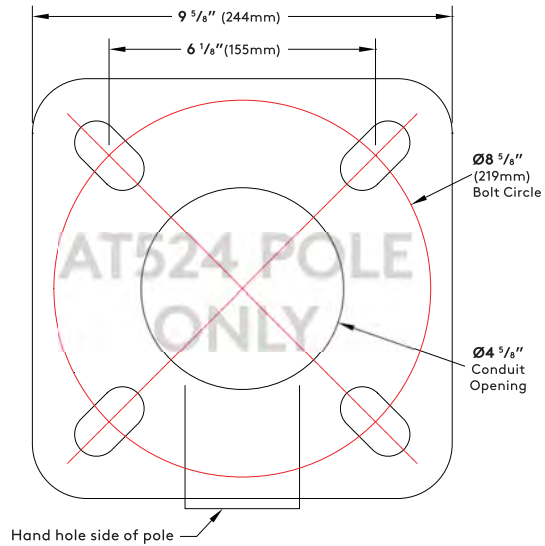

BC3 Optional Base Cover

Die cast aluminum, two piece field installable base cover

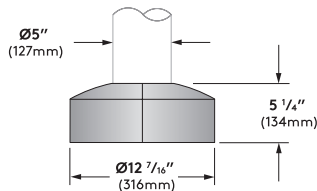

Anchor Bolt Detail

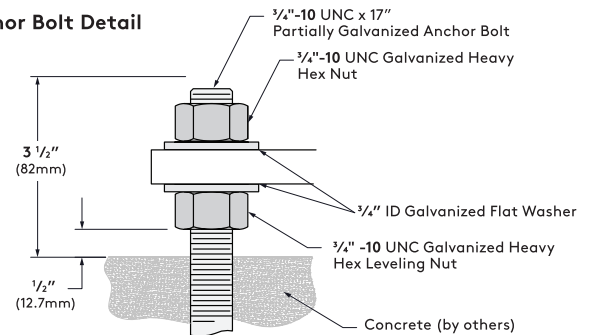

Pole Data Chart

Pole Series	Bolt Circle	Wall	EPA Information (ft ²)										Height	Finish	Options	
			85 mph	90 mph	100 mph	110 mph	120 mph	130 mph	140 mph	150 mph	160 mph	170 mph				180 mph
AT524 5" to 2.4" Round Tapered Aluminium Pole	8 5/8"	.188"	12.6	11.2	9.0	7.4	6.1	5.2	4.4	3.8	3.3	2.9	2.5	10 10ft	WH White BK Black BL Sem-Matte Black BZ Bronze SV Silver SP Specify Premium Color	BC3 Die Cast Two-Piece Aluminum decorative Base Cover REC GFCI Receptacle with weatherproof cover REC2 GFCI Receptacle with padlockable in-use cover REC3 USB & Duplex Receptacle with weatherproof cover REC4 USB & Duplex Receptacle with weatherproof padlockable in-use cover * Weatherproof cover intended for portable tools or other portable equipment connected to the outlet only when attended. For other requirements please consult factory.
			12.6	11.2	9.0	7.4	6.1	5.2	4.4	3.8	3.3	2.9	2.5	12 12ft		
			12.6	11.2	9.0	7.4	6.1	5.2	4.4	3.8	3.3	2.9	2.5	14 14ft		
			12.6	11.2	9.0	7.4	5.8	4.7	3.9	3.2	2.7	2.3	1.9	16 16ft		
			11.2	9.8	7.5	5.8	4.6	3.7	3.0	2.4	2.0	-	-	18 18ft		
			9.4	8.1	6.1	4.7	3.6	2.8	2.2	1.7	1.3	-	-	20 20ft		

Notes:

- 1) Maximum EPA ratings certified in accordance with AASHTO 2013 (LTS-6) for 3-s gust wind speeds based on Allowable Stress Design (ASD) analysis.
- 2) Consult factory for equivalent Load and Resistance Factor Design (LRFD) wind speeds.
- 3) Rated performance is dependant upon the pole being properly attached to a supporting foundation of adequate design.



Catalog Information:

LUMINAIRE: DSC4L-R5R-S1-5G350-35-[POWER CORD]-[FINISH]-UNV

POLE: A35-14-[FINISH]-T35

Date:01/27/2023

Fixture Type:

P1B

Round Pole Motion Sensor

The Selux outdoor rated sensor incorporates Passive Infrared (PIR) Technology for motion sensing and also includes built-in photocell. Sensor comes pre-installed in cast aluminum housing painted to match pole finish.

Series	Hand Hole Orientation	Dim Level	Photocell Feature	Voltage
MS Motion Sensor	00 0° Clockwise from Hand Hole	D0 (Off)	Y Yes	UNV (100-347VAC single phase or 208/230/480VAC phase-to-phase)
	09 90° Clockwise from Hand Hole	D1 (1V=10%)		
	18 180° Clockwise from Hand Hole	D3 (3V=30%)	N No	
	27 270° Clockwise from Hand Hole	D5 (5V=50%)		

Factory Defaults:

- Delay to Dim: 5 minutes
- Delay to Off: 1 hour
- Sensitivity: Max
- Custom Programming: Consult Factory

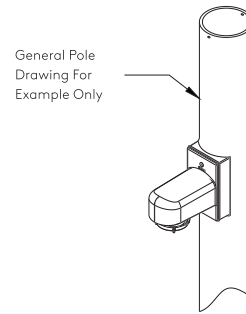
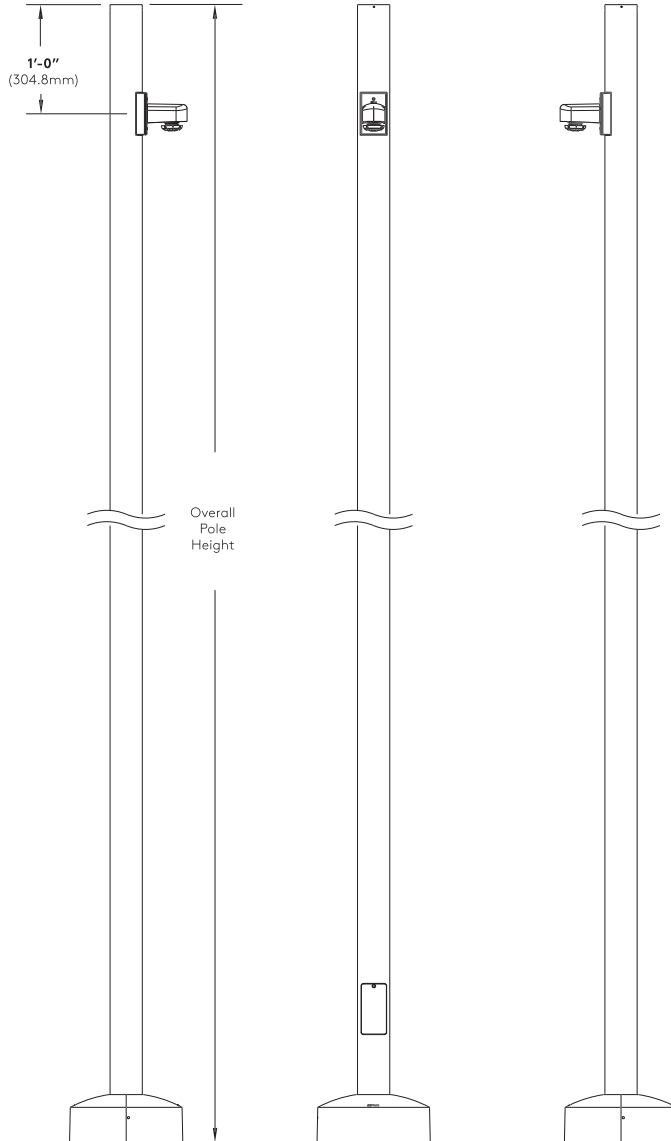

Sensor angular orientation from hand hole 0°
90° increments clockwise around pole (Type 00, 09, 18, 27)

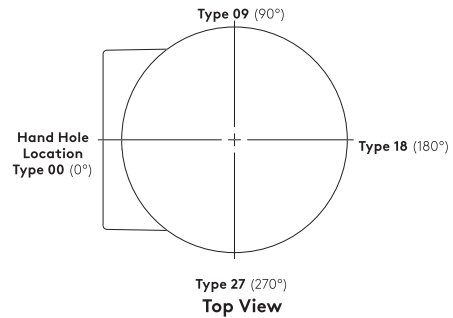

Motion Sensor Features

- Customize programming using smartphone application (Refer to the FSP-321 at www.wattstopper.com)
 - 5 Year Warranty
 - 100% Digital PIR Detection, excellent RF Immunity
 - 270° coverage pattern
 - IP66 Rated for outdoor applications
 - Made for LED light source
 - Adjustable time delays, max/min dim levels, and ramp rates
 - Suitable for Title 24 applications
- (For coverage details refer to wattstopper FSP-321 spec sheet at www.wattstopper.com)

Wiring Diagrams

Standard Wiring (120V-277V)

**When dimming is not required cap dimming wires.

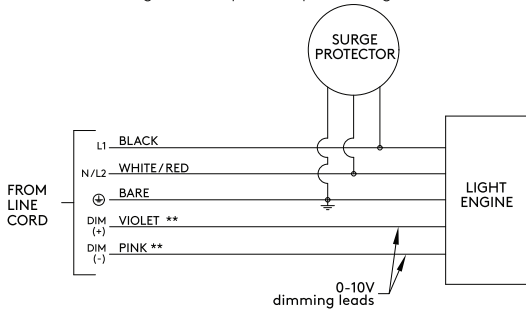

Standard Wiring (347/480V with Step-down Transformer)

**When dimming is not required cap dimming wires.

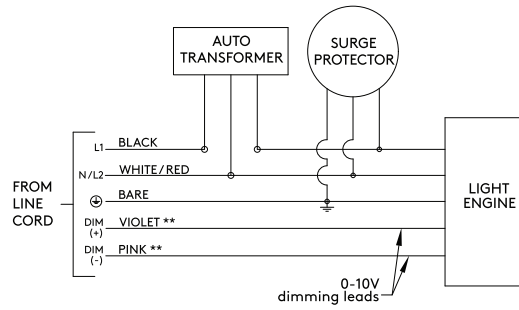

Hi-Lo Switching Option (HL) Wiring HL30 & HL50 Only

120V, 240V, 277V. When blue is energized, light output will be at "Lo" level. Specify low-level by using one of the 2 levels listed below (i.e. HL30 or HL50). For other combinations, consult factory

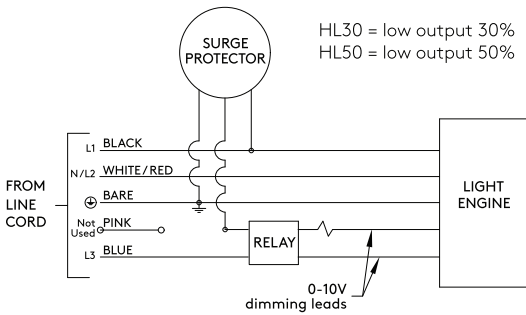

Photocell Option (TLRP) Wiring

**When dimming is not required cap dimming wires.

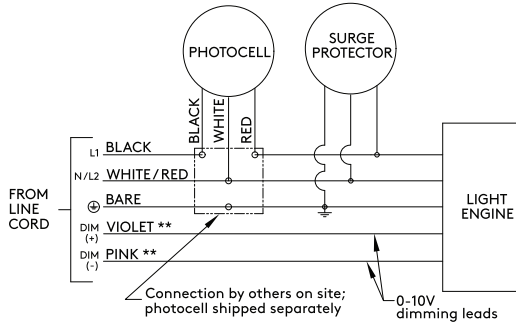

7-Pin Twist Lock Receptacle Option (TLR) Wiring

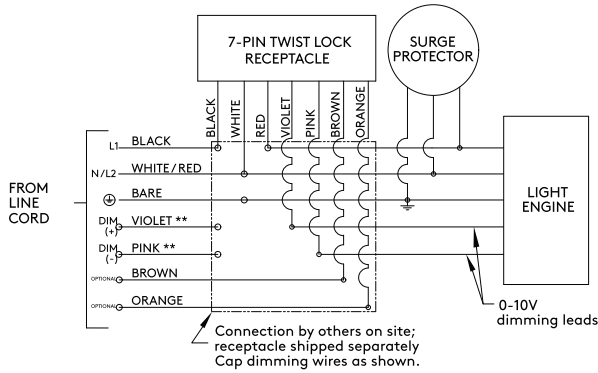

Motion Sensor Option (MS) Wiring (120-480V)

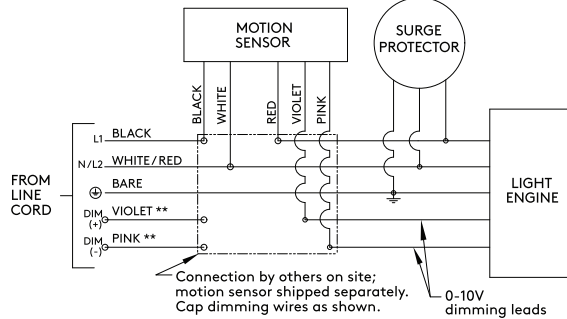

Wire Designation Table		
Source Voltage (VAC)	Wire Color	Wire Designation
120V, 277V, or 347V	Black	L1
	White	Neutral
208V, 240V, or 480V	Black	L1
	Red	L2
UNV (120V-277V)	Black	L1
	White	Neutral (120/277V) or L2 (208/240V)

Optional Accessories

TLRP,TLR, and TLRL

3-pin twist-lock receptacle with photocell, 7-pin twist-lock receptacle with shorting cap, and 7-pin twist-lock receptacle with Lutron Limelight module.

Note: TLR,TLRL and TLRP are available for all arm mounting configurations except Wall and Citalys mount (SW, LW, and C1).

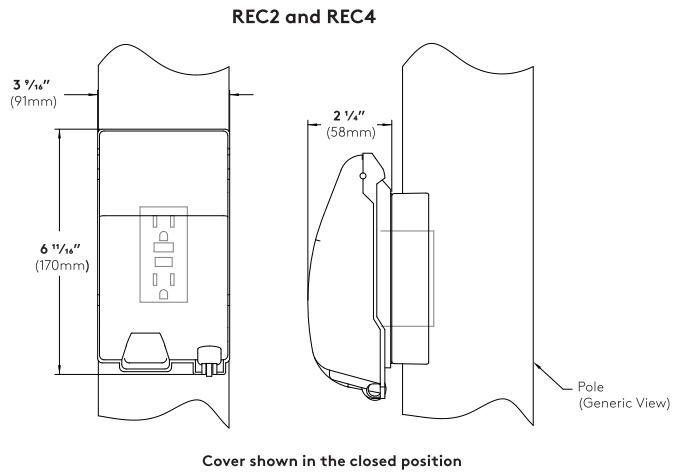
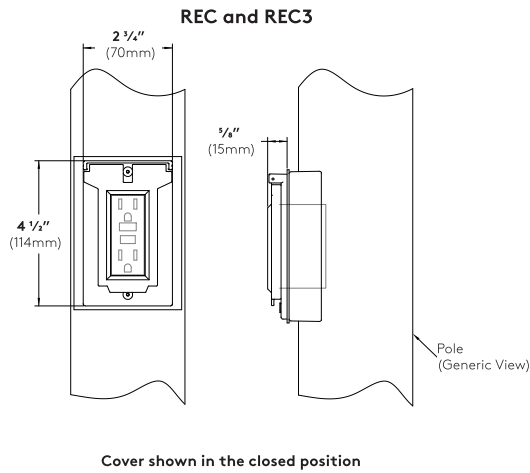
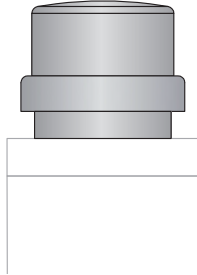

GFCI Receptacle (REC) - 120V 15A GFCI duplex receptacle with weatherproof, self-closing cover; located 36" (915mm) o.c. from base of pole, in-line with hand hole. Receptacle is intended only for portable tools or other portable equipment to be connected to outlet only when attended by operating personnel (120V only).

USB & Duplex Receptacle (REC3) (not shown) - 120V 20A duplex receptacle with USB combination ports. (1) type A and (1) type C high power 5A, 5V USB outlets. With weatherproof, self-closing cover; located 36" (915mm) o.c. from base of pole, in-line with hand hole. Receptacle is intended only for portable tools or other portable equipment to be connected to outlet only when attended by operating personnel.

REC3 does not incorporate GFCI (Ground Fault Circuit Interrupter) protection, and shall be powered by a GFCI protected branch circuit (by others).

GFCI Receptacle (REC2) - 120V 15A GFCI duplex receptacle with weatherproof, self-closing, padlockable in-use cover; located 36" (915mm) o.c. from base of pole, in-line with hand hole. Receptacle is intended only for portable tools or other portable equipment to be connected to outlet only when attended by operating personnel (120V only).

USB & Duplex Receptacle (REC4) (not shown) - 120V 20A duplex receptacle with USB combination ports. (1) type A and (1) type C high power 5A, 5V USB outlets. With weatherproof, self-closing padlockable in-use cover; located 36" (915mm) o.c. from base of pole, in-line with hand hole. Receptacle is intended only for portable tools or other portable equipment to be connected to outlet only when attended by operating personnel.

REC4 does not incorporate GFCI (Ground Fault Circuit Interrupter) protection, and shall be powered by a GFCI protected branch circuit (by others).

Photometry



R1 - Gen5 Distribution Type I/II					
Light Engine	Lumens	CCT	Input Watts	lm/W	
5G350	3,357	3000K	32	105	
5G530	4,875	3000K	47	104	
5G700	6,325	3000K	62	102	
5G900	7,548	3000K	78	97	



R2 - Gen5 Distribution Type II					
Light Engine	Lumens	CCT	Input Watts	lm/W	
5G350	3,355	3000K	32	105	
5G530	4,854	3000K	47	103	
5G700	6,321	3000K	62	102	
5G900	7,543	3000K	78	97	



R3 - Gen5 Distribution Type III					
Light Engine	Lumens	CCT	Input Watts	lm/W	
5G350	3,533	3000K	32	110	
5G530	4,875	3000K	47	104	
5G700	6,657	3000K	62	107	
5G900	7,943	3000K	78	102	



R3W - Gen5 Distribution Type III (Wide)					
Light Engine	Lumens	CCT	Input Watts	lm/W	
5G350	3,409	3000K	32	107	
5G530	4,932	3000K	47	105	
5G700	6,423	3000K	62	104	
5G900	7,664	3000K	78	98	



R4 - Gen5 Distribution Type III/IV					
Light Engine	Lumens	CCT	Input Watts	lm/W	
5G350	3,342	3000K	32	104	
5G530	4,835	3000K	47	103	
5G700	6,297	3000K	62	102	
5G900	7,513	3000K	78	96	

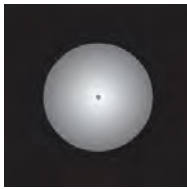

R5R - Gen5 Distribution Type V (Round)					
Light Engine	Lumens	CCT	Input Watts	lm/W	
5G350	3,624	3000K	32	113	
5G530	5,243	3000K	47	112	
5G700	6,297	3000K	62	102	
5G900	7,513	3000K	78	96	



DG - Diffuse Glass Distribution Type V (Round)					
Light Engine	Lumens	CCT	Input Watts	lm/W	
MP350	3,399	3000K	33	103	
MP530	4,944	3000K	48	103	
MP700	6,283	3000K	61	103	
MP900	7,943	3000K	77	103	



Catalog Information: LUMINAIRE: DSC4L-R5R-S1-5G350-35-[POWER CORD]-[FINISH]-UNV
POLE: A35-14-[FINISH]-T35

Date:01/27/2023
Fixture Type:

P1B

Photometry

CCT Multiplier	
2700K	0.962
3000K	1.000
3500K	1.000
4000K	1.063
5000K	1.070

TM-21 Lifetime Calculation					
Light Engine ²	Ambient Temp (°C)	Lumen Maintenance (% at hours)			Reported L ₉₀ ¹
		25K	50K	60K	
5G350	25°C	99.8%	99.8%	99.8%	L ₉₀ (12K) > 70,000 hours
	40°C	99.8%	99.8%	99.8%	L ₉₀ (12K) > 70,000 hours
5G530	25°C	99.8%	99.8%	99.8%	L ₉₀ (12K) > 70,000 hours
	40°C	99.1%	98.5%	98.0%	L ₉₀ (12K) > 73,000 hours
5G700	25°C	99.8%	99.8%	99.8%	L ₉₀ (12K) > 70,000 hours
	40°C	99.1%	98.5%	98.0%	L ₉₀ (12K) > 73,000 hours
5G900	25°C	99.1%	98.5%	98.0%	L ₉₀ (12K) > 73,000 hours
	40°C	96.6%	95.0%	93.8%	L ₉₀ (12K) > 73,000 hours

¹ Calculated in accordance with IESNA TM-21-11, projected values are within six times (6x) the IESNA LM-80-08 test duration

² Thermal measurements based on Order Code: DSC4L-R4-xx-5Gxxx-30-xx-SV-xx-UNV

TM-21 Lifetime Calculation						
Light Engine ²	Ambient Temp (°C)	Lumen Maintenance (% at hours)				Reported L ₇₀ ¹
		25K	50K	75K	90K	
MP350	25°C	97.4%	94.5%	91.8%	90.2%	L ₇₀ (15K) > 90,000 hours
	40°C	96.0%	92.2%	88.5%	86.4%	L ₇₀ (15K) > 90,000 hours
MP530	25°C	96.3%	92.8%	89.4%	87.5%	L ₇₀ (15K) > 90,000 hours
	40°C	94.9%	90.1%	85.5%	82.9%	L ₇₀ (15K) > 90,000 hours
MP700	25°C	95.2%	90.8%	86.5%	84.0%	L ₇₀ (15K) > 90,000 hours
	40°C	92.7%	85.3%	78.6%	74.8%	L ₇₀ (15K) > 90,000 hours
MP900	25°C	93.1%	86.1%	79.6%	76.0%	L ₇₀ (15K) > 90,000 hours
	40°C	83.1%	68.6%	56.7%	50.5%	L ₇₀ (15K) > 47,000 hours

¹ Calculated in accordance with IESNA TM-21-11, projected values are within six times (6x) the IESNA LM-80-08 test duration

² Thermal measurements based on Order Code: DSC4L-DG-X-MPxxx-30-XX-BL-UNV



Catalog Information:

LUMINAIRE: DSC4L-R5R-S1-5G350-35-[POWER CORD]-[FINISH]-UNV

POLE: A35-14-[FINISH]-T35

Date:01/27/2023
Fixture Type:

P1B

**Appendix C - Geotechnical Soils
Investigation Report**



Known for excellence.
Built on trust.



Geotechnical Engineering Report

Francis Myers Recreation Center
5801 Kingsessing Avenue
Philadelphia, PA

JULY 2022, REV OCTOBER 2022
File No. 14.0079893.00



PREPARED FOR:
DIGSAU
Philadelphia, PA

GZA GeoEnvironmental, Inc.

1515 Market Street, Suite 945 | Philadelphia, PA 19102
215-591-3800

32 Offices Nationwide
www.gza.com

Copyright© 2021 GZA GeoEnvironmental, Inc.



Known for excellence.
Built on trust.

GEOTECHNICAL
ENVIRONMENTAL
ECOLOGICAL
WATER
CONSTRUCTION
MANAGEMENT

1515 Market Street
Suite 945
Philadelphia, PA 19102
T: 215.591.3800
F: 267.319.1014
www.gza.com



July 29, 2022, Rev October 26, 2022
File No. 14.0079893.00

Mr. Michael Goldberg, AIA, LEED AP
DIGSAU
340 North 12th Street, Suite 421
Philadelphia, PA 19107
mgoldberg@DIGSAU.com

Re: Geotechnical Engineering Report
Francis Myers Recreation Center
5801 Kingsessing Avenue
Philadelphia, PA 19130

Dear Mr. Goldberg:

GZA is pleased to submit our revised Geotechnical Engineering Report for the above-referenced property ("Site"), which is being upgraded as part of the Rebuild Philadelphia portfolio of projects. GZA completed this Geotechnical Engineering Report using information provided by you and information independently obtained from the subsurface exploration program described within the text of the attached report. The revision to this Report pertains to the use of on-site, predominately granular soils within the planned new development building footprint.

We trust this report satisfies your present requirements. However, if you need additional information, please contact Edward Phelps at 267-464-3639 or edward.phelps@gza.com.

Very truly yours,
GZA GeoEnvironmental, Inc.

Edward Phelps, P.E. (NY)
Project Manager

Ernest Hanna, P.E.
Senior Principal

Andrew Rizk, P.E. (NY, NJ)
Consultant/Reviewer



1.0 INTRODUCTION1

2.0 BACKGROUND1

 2.1 SITE DESCRIPTION 1

 2.2 SCOPE OF WORK 1

3.0 LOCAL GEOLOGICAL SETTINGS.....2

4.0 SUBSURFACE EXPLORATION2

5.0 LABORATORY TESTING3

6.0 SUBSURFACE CONDITIONS4

 6.1 OVERBURDEN SOILS..... 4

 6.2 GROUNDWATER..... 5

7.0 FOUNDATION DESIGN RECOMMENDATIONS5

 7.1 KEY GEOTECHNICAL ISSUES 6

 7.2 SOIL DESIGN PARAMETERS 7

 7.3 SEISMIC SITE CLASS..... 7

 7.4 FOUNDATION RECOMMENDATIONS..... 8

 7.5 SLAB-ON-GRADE 8

 7.6 SETTLEMENT 8

 7.7 LATERAL EARTH PRESSURES 9

 7.8 STORMWATER MANAGEMENT AREAS 9

8.0 CONSTRUCTION RECOMMENDATIONS10

 8.1 EXCAVATIONS 10

 8.2 TEMPORARY SUPPORT OF EXCAVATION 10

 8.3 SUBGRADE PREPARATION 11

 8.3.1 Subgrade Protection 13

 8.4 FILL MATERIAL AND COMPACTION..... 13



8.5 GROUNDWATER CONTROL..... 13

8.6 REUSE OF EXISTING MATERIAL 13

8.7 RECOMMENDED ADDITIONAL GEOTECHNICAL EXPLORATION 14

8.8 QUALITY ASSURANCE AND QUALITY CONTROL (SPECIAL INSPECTIONS) 14

8.9 RECOMMENDED ADDITIONAL SERVICES 14

TABLES

TABLE 1 LABORATORY TESTING RESULTS

TABLE 2 RECOMMENDED DESIGN INDEX PROPERTIES

TABLE 3 CASED BOREHOLE INFILTRATION TEST RESULTS

TABLE 4 TYPICAL MATERIAL PROPERTIES FOR CONSTRUCTION USE

TABLE 5 COMPACTION METHODS

FIGURES

FIGURE 1 SITE LOCATION PLAN

FIGURE 2A EXPLORATION LOCATIONS ON EXISTING CONDITIONS PLAN

FIGURE 2B EXPLORATION LOCATIONS ON PROPOSED CONDITIONS PLAN

APPENDICES

APPENDIX A LIMITATIONS

APPENDIX B TEST BORING LOGS

APPENDIX C CASED BOREHOLE INFILTRATION TEST DATA

APPENDIX D LABORATORY TEST DATA

APPENDIX E EAST COAST GEOPHYSICS GEOPHYSICAL REPORT



1.0 INTRODUCTION

This report presents GZA's subsurface exploration results and foundation recommendations for the proposed new gymnasium addition at the Site in Philadelphia, PA. Our scope of services was performed in accordance with our revised proposal, dated May 6, 2022. The work was authorized by DIGSAU ("the Client"/DIGSAU). Our services are subject to the limitations presented in **Appendix A**.

On June 27 through June 29, 2022, GZA evaluated the subsurface conditions at nine locations (three soil borings and six cased borehole infiltration cased borehole infiltration tests) selected by GZA and the project civil engineer, David Mason & Associates, Inc. (David Mason).

2.0 BACKGROUND

2.1 SITE DESCRIPTION

The Site is located in the border of the Kingsessing and Southwest Philadelphia neighborhoods in the City of Philadelphia, PA, and is bound to the northwest by Chester Avenue, to the northeast by South 58th Street, to the southwest by residential homes adjacent to South Redfield Street, and to the southeast by Kingsessing Avenue. The property consists of an existing approximate 30,000 gross square feet (GSF), three-story masonry structure with a basement extending one level below existing grade. A Site Location Plan is included as **Figure 1**.

Site grades gradually slope downward from the southeast towards the general northwest, with elevations ranging between approximately El. 82 to El. 70 feet. The planned renovations include selective demolition of the existing recreation building, including the existing health annex and gymnasium. A new approximate 10,000 GSF one-story gymnasium attached to the main recreation building will be constructed to replace the existing gymnasium; first floor elevations (FFE) of the planned new construction have not been provided, and we assume that below grade structures are not planned. In addition, the construction of two subsurface detention basins (designated as Basin 1 and Basin 2) and redevelopment of the pavement and playground areas are planned. Basin 1 and Basin 2 consist of approximate footprint areas of 700 square feet (SF) and 2,470 SF, respectively. Site elevations were obtained from an Existing Conditions Plan, Sheet Number C-100, provided by the Client. The Existing Conditions Plan is part of a 100% Schematic Design Civil Drawing Set. All elevations are referenced to Philadelphia City Datum.

Cased borehole infiltration tests for stormwater control structures Basin 1 and Basin 2 were performed at El. 72 and El. 70, respectively, corresponding to depths of approximately 6.5 feet to 7 feet below ground surface (bgs). We expect cuts at those depths will be feasible.

2.2 SCOPE OF WORK

Our services included the following:

- Layout of the test borings at the Site, as selected by GZA and David Mason;
- Preparation of a Site-specific health and safety plan;
- Coordination and observation of the subsurface exploration program;
- Observation of water levels in the test borings following completion;



- Performing in-situ cased borehole infiltration testing;
- Laboratory testing of selected recovered soil samples;
- Evaluation of the subsurface conditions encountered and laboratory test data results;
- Conducting engineering analyses as a basis for our geotechnical recommendations; and
- Preparation of this report summarizing the work and recommendations.

3.0 LOCAL GEOLOGICAL SETTINGS

The Site is on the boundary between the Wissahickon Formation and Pensauken and Bridgeton Formations. The Wissahickon Formation contains oligoclase-mica schist, some hornblende gneiss, some augen gneiss, and some quartz-rich and feldspar-rich members. The Pensauken Formation overlies the Bridgeton Formation and consists of yellow to dark-reddish-brown, cemented, extensively crossbedded, feldspathic quartz sand with interbedded coarse gravel and boulders. The Bridgeton Formation is composed of extensively crossbedded, clayey, feldspathic quartz sand, stained reddish brown at its top, and either yellow or white below.

The Site lies within the Piedmont Physiographic Province in the Piedmont Upland Section. The Geologic Map of Pennsylvania indicates that the Site is between the formations consisting of Schist and Gneiss bedrock and tertiary deposits of sand and gravel that also contain silt and clay. The United States Department of Agriculture (USDA) Natural Resource Conservation Service (NRCS) Web Soil Survey indicates the soil overburden is typically urban land described as pavement, buildings and other artificially covered areas. A Site Locus Map is attached as **Figure 1**.

4.0 SUBSURFACE EXPLORATION

GZA coordinated a subsurface exploration program consisting of a total of nine (9) explorations including three (3) soil borings (designated as B-1 through B-3) and six (6) cased borehole infiltration tests (designated as IT-1 through IT-6). The exploration locations are shown on the attached **Figure 2A**. The cased borehole infiltration tests were performed in groups of three and at the general locations of the two planned detention basins (designated as Basin 1 and Basin 2). Cased borehole infiltration tests IT-1 through IT-3 were performed in the vicinity of Basin 1. Cased borehole infiltration tests IT-4 through IT-6 were performed within the Basin 2 footprint. Cased borehole infiltration tests performed for Basin 1 were offset to the north from the planned footprint due to utility conflicts. Prior to subsurface sampling at the Site, GZA retained a private utility locating subcontractor, East Coast Geophysical, Inc. (ECG), to perform ground penetrating radar (GPR) services to locate and mark-out existing utilities in the vicinity of the planned exploration locations and to field locate existing water and sewer lines behind the recreation building as requested by the Client. Water, storm sewer, and unknown subsurface utility lines were identified within the area of interest specified by the Client. A storm drain was identified in the baseball field west of the spray ground pavement area. A copy of the ECG mark-out report, showing utilities within the area of interest, is attached as **Appendix E**.

GZA subcontracted Cascade Remediation Services, LLC (Cascade) of Jackson, New Jersey, who mobilized to the Site on June 27 and completed the nine explorations over a three-day time period under full-time observation of a GZA field engineer. Utility conflicts were identified at the B-2 and IT-2 locations. Consequently, the offset location of B-2 to avoid the utility conflict resulted in the offsetting of IT-4 through IT-6 in order to maintain conformance to the Philadelphia Water Department (PWD) cased borehole infiltration testing requirements.



The borings were logged by a GZA field engineer. The three soil borings were completed to depths between approximately 12 and 20 feet bgs and the six cased borehole infiltration tests were completed to depths between approximately 6.5 and 7 feet bgs.

Cascade used a Geoprobe® 7822DT track-mounted drill rig to advance the explorations. Direct push techniques were used to advance the three test borings and hollow stem augers were used to advance the six cased borehole infiltration tests to depth. For the test borings, split spoon samples were obtained in accordance with ASTM D-1586, the Standard Penetration Test (SPT). Samples were obtained at frequent intervals as noted on the attached test boring logs. The split spoon sampler was driven 24 inches with blows from a 140-pound automatic hammer, falling 30 inches; the number of blows required to drive the sampler for each six-inch interval was recorded. The number of blows required to drive the sampler from 6 inches to 18 inches is the SPT N-value, a commonly used indicator of soil density and consistency. The SPT N-values at various depths are recorded on the boring logs. Soil samples collected from the spoons were described in accordance with a modified Burmister soil classification system, and the Unified Soil Classification System (USCS), with the USCS symbol provided on the logs. The description of each soil sample was based on visual and manual identification.

Cased borehole infiltration tests were performed in general accordance with the procedures outlined in the Philadelphia Stormwater Management Guidance Manual, which complies with the Philadelphia Water Department (PWD) Stormwater Regulations. Cased borehole infiltration test locations IT-1 through IT-6 were advanced to the depth of the proposed infiltration basin inverts. The basins are designated as Basin 1 and Basin 2, with invert elevations at approximately El. 72 feet and El. 70 feet. A 4-inch inner diameter PVC pipe was installed through the inside of the hollow-stem augers, and the augers were removed. A one-hour presoak, performed over two 30-minute intervals, was performed prior to testing. Following the presoak, cased borehole infiltration test measurements were made either on a ten-minute or thirty-minute timed interval, depending on the rate of infiltration.

Upon completion of drilling, boreholes performed in grassed areas were backfilled with soil cuttings to the ground surface and boreholes performed in paved locations were backfilled with soil cuttings to within 6 inches of surface grades and then capped with either cold asphalt patch or quick-setting concrete to match existing ground surface materials and grades.

The explorations were located by tape measurements from existing site features. The approximate as-drilled locations are shown on **Figure 2A and Figure 2B**. The test boring logs are included in **Appendix B**. Refer to the Log Key in **Appendix B** for definitions of symbols and terms used in our test boring logs. Results of the field cased borehole infiltration testing are included in **Appendix C**.

5.0 LABORATORY TESTING

Selected soil samples were sent to our soil mechanics laboratory in South Bound Brook, NJ, for water content, Atterberg Limits, and sieve analysis testing. Laboratory test results are presented in **Table 1** below, and test data sheets are included in **Appendix D**.



Table 1: Laboratory Testing Results

Sample ID (Boring, Sample)	Sample Depth (feet)	Stratum	Percent Passing No. 200 Sieve	Moisture Content
B-1, S-1T	0-1	Silty Sand [FILL]	---	10.7%
B-1, S-1B	1-2	Silt [FILL]	---	22.3%
B-1, S-2	2-4	Silty Sand	---	14.4%
B-1, S-3	4-6	Silty Sand	15.2%	8.2%
B-1, S-4	6-8	Silty Sand	29.4%	14.3%
B-1, S-5	8-10	Silty Sand	27.2%	16.5%
B-1, S-6	13-15	Weathered Rock (Silty Sand)	---	14.8%
B-1, S-7	15-17	Weathered Rock (Silty Sand)	---	9.6%
B-1, S-8	17.5-19.5	Weathered Rock (Silty Sand)	---	8.9%
B-2, S-1	0-2	Silty Sand [FILL]	---	22.4%
B-2, S-2	2-4	Sand [FILL]	---	12.9%
B-2, S-3T	4-5	Gravel and Sand [FILL]	---	13.6%
B-2, S-3B	5-6	Sand and Silt	---	34.4%
B-2, S-4	6-8	Sand and Clayey Silt	42.5%	32.8%
B-2, S-5	8-10	Weathered Rock (Silty Sand)	19.9%	12.2%
B-2, S-6	10-11.8	Weathered Rock (Silty Sand)	---	7.3%
B-3, S-6	13-15	Weathered Rock (Silty Sand)	11.8%	15.2%

6.0 SUBSURFACE CONDITIONS

6.1 OVERBURDEN SOILS

The following generalized subsurface profile summarizes the observations made at the test boring locations.

SURFACE MATERIALS – Asphalt pavement was encountered in boring locations B-1 and B-3, measuring at approximately 4 inches in thickness. The asphalt pavement at B-3 was underlain by a layer of coarse to fine GRAVEL, some fine to coarse Sand to an approximate depth of 1.5 feet bgs. Topsoil was encountered in boring B-2 at the ground surface at a thickness of approximately 3 inches and generally consisting of grayish brown, fine SAND, little Silt, roots and grass.

EXISTING FILL – Existing Fill was encountered in B-1 and B-2 immediately beneath the asphalt and topsoil, respectively, to depths of approximately 2 feet and 5 feet bgs. The Existing Fill was predominately granular and generally consisted of either brown, grayish brown, gray and brown, fine to coarse SAND, little Silt, trace to some fine to medium Gravel, trace roots, and grading to fine to medium GRAVEL and fine to coarse SAND, trace Silt to little Clayey Silt, brick fragments with depth. The Existing Fill consisted of orange-brown SILT in B-1 from approximately 1-foot to 2 feet bgs. Uncorrected SPT N-values ranged between 6 and 12 blows per foot (bpf), indicating loose to medium dense relative density for the sand and gravel and medium stiff consistency for the Silt. The Existing Fill was not observed in B-3.



SILTY SAND / SAND AND SILT – A layer of Silty Sand / Sand and Silt was encountered in the explorations at different depths:

- Below the existing fill in B-1 to an approximate depth of 13 feet bgs, for a thickness of about 11 feet;
- Below the existing fill in B-2 to an approximate depth of 8 feet bgs, for a thickness of about 3 feet; and
- Below the Surface Materials in B-3 to an approximate depth of 13 feet bgs, for a thickness of about 11 feet.

The Silty Sand / Sand and Silt layer generally consisted of either:

- Yellowish brown, dark brown, dark reddish brown, fine to coarse SAND, trace to little fine Gravel, trace to some Silt/Clay (USCS: SP-SM, SM), with laboratory test results on select samples indicating fine-grained soils percentage, by weight, from approximately 15% to 30%; and
- Yellowish brown, reddish brown, fine to coarse SAND and SILT to Clayey SILT, mica specks (USCS: SM) with laboratory test results on one sample indicating fine-grained soils percentage, by weight, of approximately 43%.

Uncorrected SPT N-values of this stratum ranged from 8 to 15 bpf, with an average of about 11 bpf, indicating medium dense material.

WEATHERED BEDROCK – Weathered Bedrock was encountered below the Silty Sand / Sand and Silt stratum at each of the three boring locations. The top of Weathered Bedrock was encountered at depths between approximately 8 and 13 feet bgs. Test borings continued into the Weathered Bedrock to depths ranging between approximately 11.8 feet and 20 feet bgs, corresponding to a thickness explored between about 3.8 feet and 6.5 feet. Boring B-2 encountered equipment refusal on apparent top of bedrock at a depth of about 11.8 feet, however, the Weathered Bedrock was not fully penetrated in B-1 and B-3. Weathered Bedrock generally consisted of yellowish brown, reddish brown, gray, white, brown, Mica Schist rock fragments friable to Sand, Gravel, and Silt (USCS: SP-SM, SM, GM). Laboratory test results on select samples indicated fine-grained soils percentage, by weight, from approximately 12% to 20%. Uncorrected SPT N-values measured in the Weathered Bedrock ranged from 20 bpf to greater than 50 bpf or spoon refusal (50 blows for less than 6-inch penetration), indicating medium dense to very dense material.

6.2 GROUNDWATER

The samples obtained in the borings at the time of drilling and sampling were observed to be moist, not wet, however apparent groundwater was encountered in B-1 at a depth of approximately 18 feet bgs after drilling completion following a 15-minute stabilization period. Groundwater levels will fluctuate due to changes in temperature, precipitation, season, and other factors not prevalent at the time of our readings.

7.0 FOUNDATION DESIGN RECOMMENDATIONS

Geotechnical analyses and recommendations were generally based on the 2018 International Building Code which is adopted as the Philadelphia Building Code.



7.1 KEY GEOTECHNICAL ISSUES

We have identified the following geotechnical issues that will impact design and construction of the proposed development:

- The soils beneath the proposed gymnasium footprint were unexplored and were not directly characterized via the test borings due to the following reasons:
 - The test boring locations could not be placed within the proposed gymnasium footprint due to the restricted access within existing public playground areas;
 - The location of the planned stormwater basin structures governed the placement of B-1 and B-2 due to the PWD requirements for cased borehole infiltration test proximity to exploratory borings; and
 - GZA was requested to locate boring B-2 further north from the original proposed location to within the estimated footprint of a historical 2 ½ story building that was demolished during the 1960's renovations to collect information and characterize possible buried fill material from the former construction. Utility conflicts in the field also caused the boring to be relocated slightly further away from the proposed building addition.

Existing Fill material was encountered in boring B-2 where there was a former 2 ½ story building that was demolished. Similarly, there was another former 2 ½ story building that was demolished, located within the planned building footprint, as shown in **Figure 2A**. We anticipate that Existing Fill material will be encountered at that location, but due to the above limitations, a test boring was not performed within the footprint. We recommend that additional explorations (test pits or test borings) be performed within the unexplored building footprint to confirm subsurface conditions. This could consist of test pit excavations at the time of construction, however, we would recommend that access provided and additional borings performed during design development to reduce the potential for unanticipated subsurface conditions resulting in considerable redesign efforts.

- Unsuitable existing fill or natural soils with loose soils were encountered at depths of up to approximately 8 feet bgs at the boring locations. The existing fill soils encountered in the proposed building area are not suitable for shallow foundation or floor slab support and will require either undercutting, excavation and replacement in a controlled manner, or soil improvement. Undercutting of the unsuitable bearing material shall consist of excavating and replacing with structural fill or granular fill, and compacted in a controlled manner. Unsuitable materials (existing fill, loose natural soils, or demolition debris) should be removed within the lateral extent of the proposed building footprint and adjacent improvements, up to 10 feet beyond the limits of the proposed building and improvement areas. Unsuitable soils that are deleterious may not be reused under the building footprint; however, other unsuitable soils excavated may be reused to raise grades if placed in a controlled manner as recommended within this report. Foundations should bear on medium dense and stable native soils or weathered bedrock or controlled compacted structural fill or granular fill placed atop of these materials. Alternatively, consideration could be made for ground improvement beneath the building areas consisting of compacted or rammed aggregate piers (RAPs) or rigid inclusions, such as controlled modulus columns (CMCs).
- Refusal on apparent top of bedrock was encountered in boring B-2 at 11.8 feet bgs (El. 65.0), which is the site of the Basin 2 construction. This should be considered by the stormwater designers.
- The urban fill encountered in B-2 contained miscellaneous man-made materials. Brick fragments were encountered at boring location B-2. The existing urban fill that contains deleterious materials (wood, organics, etc.) is not suitable for reuse as structural fill, granular fill or controlled compacted fill.



- The laboratory test results determined that the Silty Sand / Sand and Silt (Silty Sand) stratum contain a moderate percentage, by weight, of fines (ranges from 15% to 43%) and are generally poorly graded above 8 feet bgs. These materials are expected to be excavated for the construction of shallow foundations. These materials and more granular portions of the Silty Sand would provide a suitable source of granular fill or controlled compacted fill/backfill if moisture conditioned and deleterious materials are removed. Existing Fill can be reused for pavement, courtyard, and landscaping areas following our recommendations in the Construction Considerations section of our report. The Clayey Silt strata and portions of the existing urban fill, with higher fines content will be more susceptible to strength degradation when exposed to moisture, less stable, and are generally not suitable for reuse as structural fill. These materials may also be reused in landscape areas or other non-structural areas, if applicable.

7.2 SOIL DESIGN PARAMETERS

We anticipate that pavement subgrades and shallow foundation excavations will encounter the Silty Sand / Sand and Silt stratum. The following properties of subsurface materials, in their unimproved state, are recommended for design purposes.

Table 2: Recommended Design Index Properties

Soil Parameters	Units	Existing Fill	Silty Sand / Sand and Silt	Weathered Rock	New Compacted Granular Fill
Friction Angle, ϕ	degrees	30	32	36	36
Unit Weight- Moist, Unsaturated, γ_m	pcf	115	115	125	125
Passive Lateral Earth Pressure Coefficient	K_p	0.33	0.31	3.85	3.85
Active Lateral Earth Pressure Coefficient	K_a	3.00	3.25	0.26	0.26
At-Rest Lateral Earth Pressure Coefficient	K_0	0.50	0.47	0.41	0.41
Net Allowable Bearing Capacity	psf	---	3,000	4,000	4,000
Vertical Modulus of Subgrade Reaction	pci	---	100	125	130
Friction Coefficient Against Sliding Resistance	Unitless	---	0.35	0.45	0.55

Table Notes: pcf = pounds per cubic foot, deg = degree, psf = pounds per square foot.

- It is assumed that Structural Fill will consist of importing readily available nearby sources of granular materials consistent with our recommendations, or reuse of suitable, granular portions of the onsite soils as mentioned above.
- Assumes New Granular Fill placed over medium dense granular soils or weathered bedrock.
- Allowable bearing capacity is based on the settlement criteria below.

7.3 SEISMIC SITE CLASS

GZA recommends an overall designation of Site Class D – Stiff soil profile. Using a Site Class D, the corresponding spectral response for 0.2 second (S_0) and 1.0 second (S_1) acceleration is 0.18g and 0.047g respectively. The resulting Site coefficient F_a and F_v is 1.6 and 2.4, respectively.



7.4 FOUNDATION RECOMMENDATIONS

The test borings indicated that the site is favorable for use of shallow foundation and slab on grade construction. However, depending on the first-floor elevation of the planned new gymnasium, some subsurface soil improvement could be needed. Over excavation of fill encountered below foundation bearing grades (foundation subgrades) will be required, as well as, the possible need to improve unsuitable natural soils via placement in controlled lift thickness and compaction. Soils that are unsuitable will require removal and replacement with controlled compacted structural fill or granular fill, or the bottom of the foundation could be lowered as needed to reach the intended suitable bearing stratum. The lateral extent of soil removal should extend a minimum of one foot beyond the outside edges of the footing for every one foot of over-excavation depth required to remove the existing fill or the loose natural materials from below the footing subgrade level. The over excavations should be backfilled with granular fill, structural fill or suitable on-site materials meeting the gradation criteria of either fill type. The proposed shallows foundations should bear on:

1. A compacted suitable natural overburden soil bearing grade that consist of at least a medium dense granular soil (Silty Sand / Sand and Silt or Weathered Rock); or
2. Granular or structural fill placed over (atop) the materials provided above.

Spread footings can be sized based on the maximum allowable net bearing pressures provided in **Table 2** above, assuming the recommendations provided within this Report are followed. Foundations should be embedded to a minimum of 3-feet below lowest adjacent grades for frost protection, or more if required by local building codes.

Foundations subject to eccentric loading, as the result of lateral loads and overturning moments, should be sized such that the resultant of the loads, is within the middle third of the foundation and that no portion of the footing is in tension. Maximum edge bearing pressures, for eccentrically loaded footings, should not exceed the above net allowable bearing pressure.

Consideration can also include excavation of the unsuitable soils and replacement of those excavated soils that do not contain wood and/or organics in a controlled, compacted manner to raise site grades under the building footprint. Based on the test borings, the soils are predominately granular (sandy), with up to about 40% by weight of fine-grained soils. Soils with a percentage of fine-grained particles greater than 15% by weight are more difficult to place due to its tendency to degrade with excess moisture. So, in wet and/or cool weather, these materials are more difficult to place and compact. However, if properly placed in accordance with the recommendations herein, granular (sandy) soils would be suitable for slab-on-grade or shallow foundation support.

7.5 SLAB-ON-GRADE

Slab-on-Grades must bear on either new compacted granular fill placed after excavation of unsuitable soils, or on natural medium dense granular soil. The slab-on-grade may be designed using a modulus of subgrade reaction of 130 pounds per cubic inch (pci) for slabs bearing on these materials, referenced to a 1-foot by 1-foot plate area. The recommended modulus value is contingent on subgrade preparation work being performed as described in the Construction Recommendations section of this report. We recommend a minimum 6-inch-thick porous bedding layer be provided below the slab to provide a capillary break between the underlying subgrade soils and the concrete slab.

7.6 SETTLEMENT

It is estimated that foundations bearing on the materials described above and sized and constructed in accordance with GZA's recommendations presented in this report will undergo total settlement of 1-inch or less, with the majority



occurring during compaction and initial loading. The maximum expected differential settlement between footings is expected to be up to ½ inch.

Provided unsuitable materials (existing fill and loose silty sands) are removed, and small increases in site grades (less than 2 feet of fill) are planned, then long term settlement is not anticipated to exceed 1-inch. Planned site grades appear to require minor cuts and fills such that the long-term settlement will likely not occur.

7.7 LATERAL EARTH PRESSURES

All below grade walls (below the existing slab on grade elevation), foundations, and slabs should be designed to resist lateral earth pressures and full hydrostatic pressure. An equivalent soil fluid unit weight of 60 pounds per cubic foot (pcf) should be used for the design of all rigid, fixed walls that are fully drained. An equivalent soil fluid pressure of 40 pcf should be used for the design of all flexible walls or walls which are free to rotate that are fully drained and 30 pcf should be used below the water table, plus hydrostatic forces. Where the calculated earth pressure behind walls is less than 250 pounds per square foot (psf), it should be increased to 250 psf to account for stresses created by compaction or work activities within 5 feet of the wall.

An additional uniform horizontal pressure should be used for design of temporary and permanent walls where surcharges are anticipated due to, for example, pedestrian or vehicular traffic, foundations loads, etc. Such additional uniform horizontal pressure should be equal to one-half of the anticipated uniform vertical surcharge load which, at a minimum, shall include a 250 psf horizontal load where adjacent to access / travel ways and/or machine foundations, and a 50 psf nominal horizontal pressure elsewhere.

Backfill placed against walls should consist of on-Site granular soils or imported granular fill meeting the requirements of **Table 4** below. For the granular values to be valid, the granular backfill should extend out from the base of the wall at an angle of at least 45° and 60° from vertical for the active and passive cases, respectively. Additional design considerations are required where these conditions are not met.

7.8 STORMWATER MANAGEMENT AREAS

GZA performed six (6) cased borehole infiltration test (designated as IT-1 through IT-6) concurrently with the subsurface exploration to evaluate in-situ infiltration rates at the two basin locations. The two planned subsurface stormwater basins, Basin 1 and Basin 2, are shown to have a footprint of 700 SF and 2470 SF, respectively. Cased borehole infiltration tests were performed in groupings of three, where IT-1 through IT-3 and IT-4 through IT-6 were performed within 10 feet of boring locations B-1 and B-2, respectively, as required under The Philadelphia Stormwater Management Guidance Manual. The two soil borings revealed the presence of existing urban fill underlain by a natural silty sand layer, and further underlain by a weathered rock layer than generally consisted of sand with varying amounts of gravel and silt.

The cased borehole infiltration testing depths were determined by David Mason, with Basin 1 and Basin 2 inverts at El. 72 feet and El. 70 feet, respectively. Groundwater was encountered in B-1 at a depth of about 18 feet bgs, which was below the infiltration testing depth and met the minimum requirements for distance to a limiting layer. Groundwater was not encountered at B-1.

The test hole locations are shown on the attached **Figure 2A** and **Figure 2B** and the corresponding infiltration test logs are attached as **Appendix C**. The unfactored permeability rates as determined by the PWD calculation methods are provided in **Table 3** below. Please note that an appropriate factor of safety should be applied to the calculated infiltration rates to determine design infiltration rates.



Table 3: Cased Borehole Infiltration Test Results

Location ID	Test Depth (feet)	Stratum	Approximate Cased borehole infiltration Rate (in/hr)
IT-1	6.3	Silty Sand	0.0
IT-2	6.5	Silty Sand	37.4
IT-3	6.5	Silty Sand	41.8
IT-4	6.5	Sand and Silt	15.8
IT-5	7	Sand and Silt	1.4
IT-6	7	Sand and Silt	7.2

8.0 CONSTRUCTION RECOMMENDATIONS

8.1 EXCAVATIONS

Excavations should be in accordance with current United States Department of Labor, Occupational Safety and Health Administration (OSHA) guidelines to protect workers and others during construction. Excavations must be shored, sloped, or benched, as required by the United States Department of Labor, Occupational Safety and Health Administration (OSHA). Per OSHA Standard 29 CFR 1926 Subpart P, the existing fill soils present at the Site should be classified as Type “C” soils. Excavations should also be in accordance with local, State, and Federal safety regulations. Due to the granular fill soils and overall loose relative density, excavations are expected to slough or cave rapidly. Exposed excavation slope faces should be protected. The geotechnical engineer should evaluate the stability of proposed slopes.

We are providing this information solely as a service to our Client. Under no circumstances should the information provided below be interpreted to mean that GZA is assuming responsibility for construction Site safety or the Contractor’s activities; such responsibility is not being implied and should not be inferred.

As a safety measure, it is recommended that all vehicles, construction equipment, and soil stockpiles be kept a minimum lateral distance from the crest of slopes equal to no less than the slope height. Exposed slope faces should also be protected against the elements.

8.2 TEMPORARY SUPPORT OF EXCAVATION

Temporary Support of Excavation (SOE) may be required for the construction of the subsurface stormwater basins or other below grade construction if close to nearby structures or improvements, or where there are site constraints. Specific details for the basins were not provided, however, based on infiltration testing elevations of El. 72 for Basin 1 and El. 70



for Basin 2, approximately 6 feet to 8 feet of excavation depth may be required. We anticipate most excavations can be sloped safely per OSHA guidelines, however, temporary SOE may be implemented. The excavation will likely occur in an area of existing fill and natural silty sand / sand and silt. SOE walls with unbalanced backfill levels on opposite sides should be designed for earth pressures. Earth pressures will be influenced by structural design of the SOE, conditions of wall restraint, methods of construction and/or compaction, and the strength of the materials being restrained. SOE should be designed to resist lateral earth pressures due to soil weight, neighboring foundation loads, groundwater pressure, and other surcharges. Recommended lateral earth pressure coefficients for SOE design are provided in **Table 2**.

Auger and split-spoon sampler refusal was encountered at approximately 11.8 feet bgs at boring location B-2, which is in the footprint of Basin 2. SOE wall design for Basin 2, if required, must consider the presence of apparent sound bedrock.

If SOE walls are not fully drained, the design must consider the possibility of hydrostatic loading against the wall. In addition, a uniform horizontal pressure equal to one-half of the anticipated vertical surcharge load should be used for design of permanent and temporary walls where surcharges are anticipated due to vehicular traffic, adjacent footings, etc.

8.3 SUBGRADE PREPARATION

All deleterious materials, surface materials, existing fill, loose silty sand / sand and silt, as well as materials resulting from the demolition of existing foundations, within the proposed developed areas and at least 10 feet beyond the building and improvement area should be removed as part of construction. For pavement and courtyard areas, these materials should be removed within 2 feet of the subgrade elevation. Following its removal and excavation to proposed subgrades, the exposed soil subgrades should be compacted with a vibratory, smooth steel drum roller to a firm and unyielding condition. The subgrade preparation and compaction should be observed by a qualified geotechnical representative. Any loose, soft, wet areas or disturbed areas of the soil subgrade which appear wet or unstable should be undercut and replaced with granular fill or compacted suitable soils. Demolition debris should be disposed of in accordance with local, state, and federal regulations.

All subsurface utility piping and structures and related fill or backfill should be completely removed from within the construction limits and the utilities rerouted beyond the proposed building limits. Where rerouted, the utilities should be moved an adequate distance so that the future utility excavation does not undermine proposed foundations and foundations do not impose load on the utilities. Any cutoff or abandoned utilities or porous bedding layers that may transmit water toward the proposed building should be cutoff and sealed. Any existing utilities to remain should be accommodated in the design. All existing foundations and building remnants shall be completely removed from the new building area during demolition and excavation to subgrade.

Excavation to the proposed foundation bearing grades should be performed using a method which reduces disturbance to the bearing subgrade. GZA recommends using a backhoe equipped with a smooth blade bucket for excavation to final subgrade elevations in soil. All loose, disturbed soil should be removed. Upon excavation to the proposed subgrade, the prepared subgrades should be observed and evaluated by a qualified geotechnical representative. Subgrades, which are not suitable, should be further undercut to a suitable grade. Controlled Granular Fill or compacted suitable soils beneath foundations should be placed and compacted on a suitable subgrade which has been observed and/or tested by a qualified geotechnical representative.

Over excavation to remove unsuitable material should be performed based on evaluation of the conditions by the on-site qualified geotechnical representative. Resulting over-excavations should be backfilled with a controlled structural fill (Sand-Gravel Fill, Granular Fill, or other approved Suitable Soil as noted below on **Table 4**) and compacted following the recommendations noted in **Table 5**. A separation geotextile can be used in undercut areas that are soft, wet or in an



otherwise deleterious condition. Compaction within utility trenches shall be done with a suitable walk-behind compactor and observed by an on-site qualified geotechnical representative.

Table 4: Typical Material Properties for Construction Use

Sieve Size	Percent Finer By Weight			
	Sand-Gravel Fill	Granular Fill	¾-Inch Crushed Stone	1½-Inch Crushed Stone
*	100	100	-	-
1½-inch	-	-	-	100
1-inch	-	-	-	85-100
¾-inch	-	-	90-100	10-40
½-inch	50-85	-	10-50	0-8
No. 4	40-75	-	0-5	-
No. 10	30-60	30-95	-	-
No. 40	10-35	10-70	-	-
No. 100	5-20**	-	-	-
No. 200	0-8	0-10	-	<1

* The maximum recommended stone size is 4 inches where used as a base course below slabs; elsewhere, maximum stone sizes should be 2/3 of the loose lift thickness.

** The amount passing the No. 100 sieve should be between forty percent (40%) and seventy percent (70%) of that amount passing the No. 40 sieve.

Table 5: Compaction Methods

Compaction Method	Max. Stone Size*	Maximum Loose Lift Thickness		Minimum Number of Passes	
		Below Structures and Pavement	Less Critical Area	Below Structures and Pavement	Less Critical Area
GRANULAR FILL, SAND-GRAVEL FILL, CRUSHED STONE					
Hand-operated vibratory plate or light roller in confined areas	4"	6"	8"	4	4
Hand-operated vibratory drum rollers weighing at least 1,000# in confined areas	6"	10"	12"	4	4
Light vibratory drum roller	8"	12"	18"	4	4
Min. weight at drum 3000# Min dynamic force 10,000#					
Medium vibratory drum roller	8"	18"	24"	6	6
Min. weight at drum 10,000# Min dynamic force 20,000#					

* Indicates not to exceed more than 2/3 the lift thickness.



8.3.1 Subgrade Protection

All bearing grades should be protected from precipitation, frost, and surface water. No water should be allowed to accumulate on bearing grades. GZA recommends that foundations be constructed promptly after excavation and observation of the bearing grade to limit the potential for bearing grade degradation. The use of a lean concrete "mud mat" to protect the subgrade should also be considered for protecting the foundation bearing grade. Foundation bearing grades should not be allowed to freeze, either prior to or after construction of foundations. If bearing grades are not protected and degrade, they must be undercut accordingly. Foundation excavations should be backfilled as soon as possible and should be backfilled prior to construction of the superstructure for bearing capacity reasons. It is recommended that foundation excavations, within slab-on-grade, be backfilled with a Granular Fill. The overburden soils will be sensitive to disturbance and strength degradation in the presence of excess moisture. Construction traffic over exposed subgrades should be minimized. The contractor should plan and conduct its operations in a manner which protects and considers the sensitivity of the soils to moisture and frost. A gravel-working mat, with underlying separation geotextile, may be appropriate to protect subgrades in these soils. If the exposed subgrades should become disturbed, they should be undercut accordingly.

It is expected that excavations for shallow foundations will not encounter groundwater conditions that would require implementation of a dewatering system. Refer to the *Groundwater Control* section of this report for additional recommendations.

8.4 FILL MATERIAL AND COMPACTION

Imported fill to be placed below foundations or slabs should consist of Structural Fill meeting the gradations outlined in **Table 4** for Sand-Gravel Fill or Granular Fill. All fill should be free from ice, snow, roots, sod, rubbish, and other deleterious or organic matter.

All fill should be compacted to at least 95 percent of its maximum dry density obtained from the modified Proctor Test (ASTM D-1557) in structural areas and 92 percent compaction in non-structural areas.

A minimum thickness of six inches of structural fill is recommended as bedding material beneath concrete slabs and should be compacted as recommended in Table 5.

Guidance for lift thickness versus compaction equipment is provided in **Table 5**. Lift thicknesses should be adjusted as required to achieve the minimum compaction requirements. The Contractor should reduce or stop vibration if pumping or weaving of the subgrade is observed and opt for static compaction efforts instead.

8.5 GROUNDWATER CONTROL

Groundwater is not expected to be encountered during shallow foundation excavations, but precipitation may accumulate in open excavations. The Contractor should be prepared to evacuate water that enters the excavations. We anticipate that this temporary groundwater control during construction can be achieved with submersible pumps.

Surface water should be diverted away from open excavations and prevented from accumulating on exposed subgrades. As noted earlier, the exposed soil subgrades will be susceptible to strength degradation in the presence of excess moisture.

8.6 REUSE OF EXISTING MATERIAL

The existing Site soils are predominantly granular but contain a moderate amount of fines, up to about 45% by weight. Site soils that are anticipated to be excavated for pavement, slab, and shallow foundation construction consist of the



Existing Fill, Silty Sand / Sand and Silt strata and can be generally classified under the Unified Soil Classification System as SM, SP-SM, SW-SM, and GM. The portions of the on-site soils consistent with natural Silty Sand material that is more closely consistent with “Granular Fill,” do not contain deleterious particles, and can be moisture conditioned to permit adequate placement and compaction may be re-used as fill or backfill to raise grades to subgrade level.

Poorly graded sand with moderate to high fines percentage provide relatively poor material for reuse as structural fill as they are highly sensitive to moisture related compaction and stability problems. As the percentage of fine-grained soils increases, the resulting soil matrix becomes more sensitive to the presence of moisture and its strength decreases. These materials can be reused below pavement and courtyard areas, landscape, berms, and other non-structural areas. The Site designer and/or contractor should consider this in determining the suitability of reusing on-Site soils.

The existing fill materials and portions of the overburden soil materials that are deemed to be unsuitable should be completely excavated and replaced with granular fill, placed and compacted in accordance with the recommendations presented in **Tables 4 and 5** of this report.

8.7 RECOMMENDED ADDITIONAL GEOTECHNICAL EXPLORATION

As mentioned above, our subsurface exploration indicated that unsuitable existing fill and loose natural material was encountered to a depth of 8 feet bgs. During the time of our field exploration, the test borings and cased borehole infiltration tests were strategically located to avoid trees, restricted access to the public playground areas, satisfy the requirements of the PWD manual for the proposed stormwater basins, and characterize possible existing fill material underlying the former 2 ½ story building (as requested by the Client) while still evaluating the information to provide foundation design and construction recommendations. As a result, the explorations were located outside of the proposed building footprint. When structural foundation design has been finalized, either before or during demolition activities, we recommend that additional explorations (either test pits and/or test borings) be performed within the building footprint when public access to the playground area is suspended to evaluate the subsurface soils and determine whether our recommendations herein require modification. In addition, another 2 ½ story former building is generally situated within the footprint, and is possibly underlain by existing fill, similarly to location B-2. Additional explorations would provide assessment of the quality of the existing fill and lateral and vertical extent of unsuitable fill and native soils.

8.8 QUALITY ASSURANCE AND QUALITY CONTROL (SPECIAL INSPECTIONS)

We recommend that GZA, who is knowledgeable in soils and foundations and with this project, be retained to review project construction documents and to observe subgrade preparation and required earthwork to reduce the potential for unexpected circumstances during the bidding and construction process and to expedite resolution should unanticipated conditions be encountered. Actual conditions exposed during construction should be observed and documented. This includes observing that the appropriate bearing stratum has been reached and that the subgrade has been properly prepared for foundation construction. We anticipate that the following construction observation activities will be required for work discussed in this report:

- Subgrade Inspection
- Subsurface Conditions – Fill Placement & In-Place Density

8.9 RECOMMENDED ADDITIONAL SERVICES

Due to our familiarity with the proposed development and the subsurface conditions at the site, we recommend that GZA be retained to perform the following additional services (in addition to those noted above):



- Supplemental explorations as described in this report
- Review of foundation related structural drawings
- Review of contractor foundation-related submittals
- Field observation of earthwork, foundation construction and excavation support (if needed)



Figures

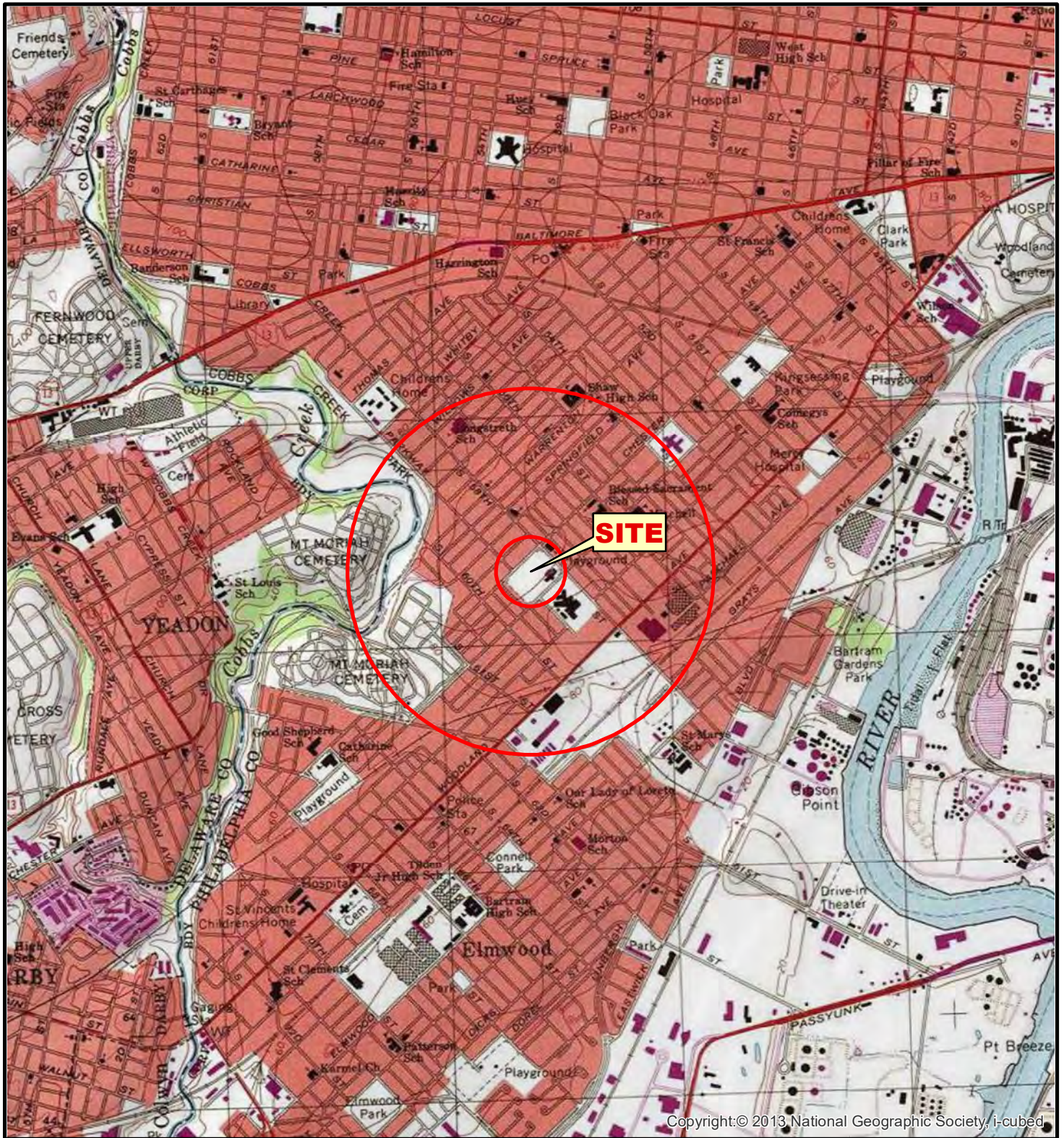

Copyright:© 2013 National Geographic Society, i-cubed

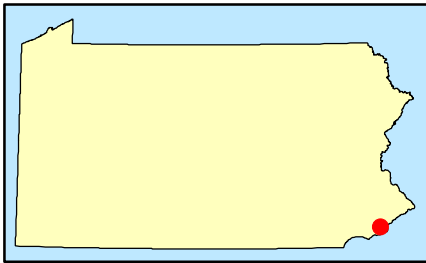

SOURCE : THIS MAP CONTAINS THE ESRI ARCGIS ONLINE USA TOPOGRAPHIC MAP SERVICE, PUBLISHED JUNE 19, 2019 BY ESRI ARCGIS SERVICES AND UPDATED AS NEEDED. THIS SERVICE USES UNIFORM NATIONALLY RECOGNIZED DATUM AND CARTOGRAPHY STANDARDS AND A VARIETY OF AVAILABLE SOURCES FROM SEVERAL DATA PROVIDERS.

Data Supplied by :



PROJ. MGR.: EP
 DESIGNED BY: AJP
 REVIEWED BY: EP
 OPERATOR: AJP
 DATE: JULY 2022

SITE LOCUS MAP
SHOWING 500 FOOT & 1/2 MILE OFFSETS
FRANCIS MYER RECREATION CENTER PROJECT
5801 KINGSESSING AVE
PHILADELPHIA, PENNSYLVANIA

JOB NO.
 14.0079893.00
 FIGURE NO.
1

© 2022 - GZA GeoEnvironmental, Inc.
 GZA-1407989300-Exploration Location Plan.dwg [Existing Conditions] July 25, 2022 - 10:08am alexander.perez

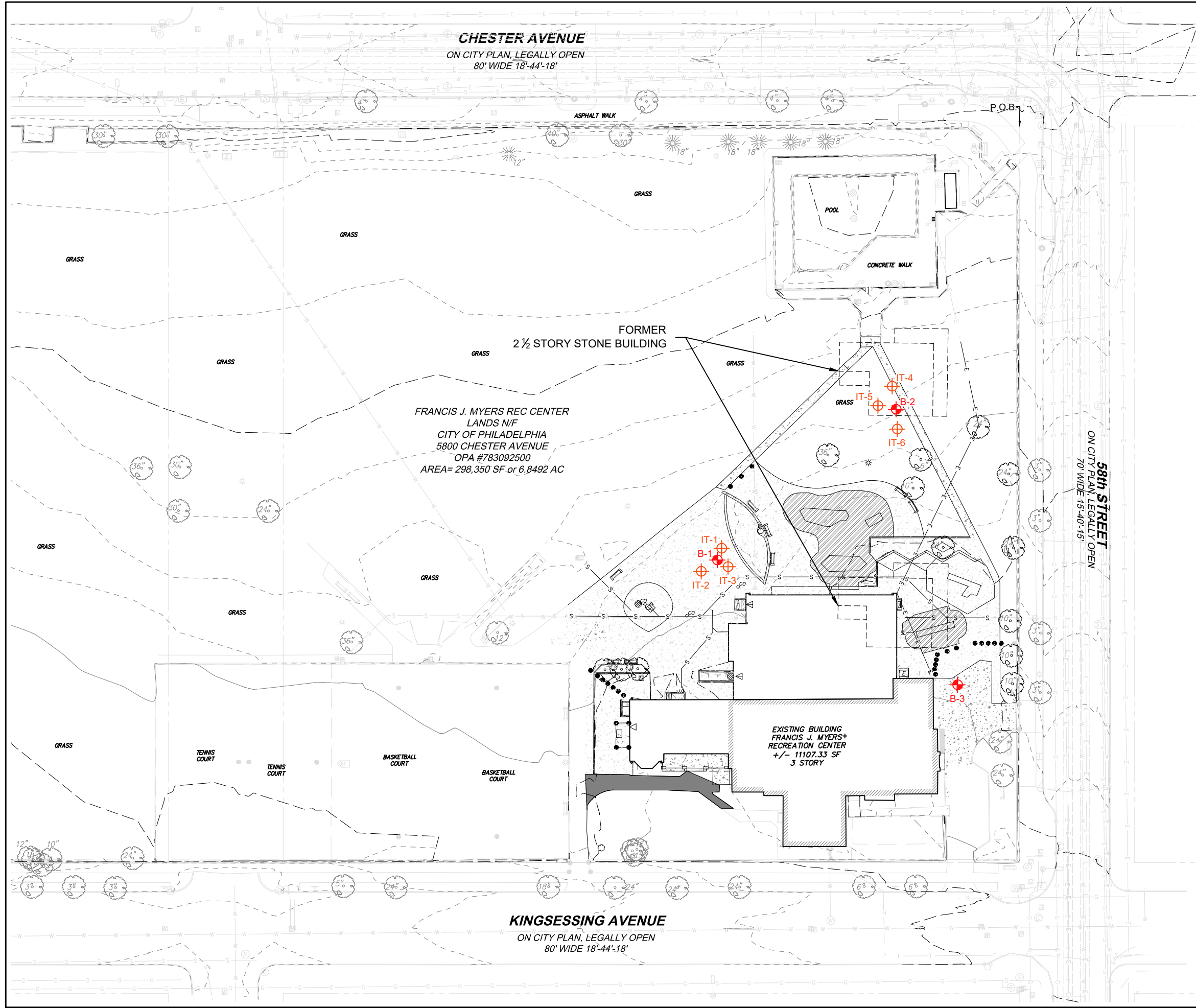

LEGEND

- GEOTECHNICAL SOIL BORING (FEBRUARY 2022)
- CASED BOREHOLE PERCOLATION TEST (FEBRUARY 2022)

SOURCE:

1. THE BASE PLAN WAS OBTAIN FROM ELECTRONIC FILES PROVIDED BY DIGSAU AND PREPARED BY DAVID MASON & ASSOCIATES ENTITLED "EXISTING CONDITIONS PLAN", DATED: 05/13/2022, ORIGINAL SCALE: 1"=20', DRAWING NO.: C-100, FILE: 2022-05-11_FJM-100%SD-CIVIL-SET.PDF.

FORMER 2½ STORY BUILDINGS WERE TRACED FROM "SITE PLAN FOR DEMOLITION WORK AT FORMER PRESBYTERIAN ORPHANAGE", CITY OF PHILADELPHIA-DEPARTMENT OF RECREATION, MARCH 29 1963.
2. THE LOCATION, AND ELEVATIONS OF THE BORINGS, AND INFILTRATION TEST LOCATIONS WERE APPROXIMATELY DETERMINED BY TAPE MEASUREMENTS AND LINE OF SIGHT FROM EXISTING SITE FEATURES. THE DATA SHOULD BE CONSIDERED ACCURATE ONLY TO THE DEGREE IMPLIED BY THE METHOD USED.

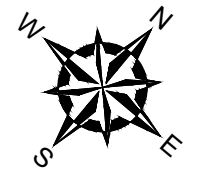

UNLESS SPECIFICALLY STATED BY WRITTEN AGREEMENT, THIS DRAWING IS THE SOLE PROPERTY OF GZA GEOENVIRONMENTAL, INC. (GZA). THE INFORMATION SHOWN ON THE DRAWING IS SOLELY FOR USE BY GZA'S CLIENT OR THE CLIENT'S DESIGNATED REPRESENTATIVE FOR THE SPECIFIC PROJECT AND LOCATION IDENTIFIED ON THE DRAWING. THE DRAWING SHALL NOT BE TRANSFERRED, REUSED, COPIED, OR ALTERED IN ANY MANNER FOR USE AT ANY OTHER LOCATION OR FOR ANY OTHER PURPOSE WITHOUT THE PRIOR WRITTEN CONSENT OF GZA. ANY TRANSFER, REUSE, OR MODIFICATION TO THE DRAWING BY THE CLIENT OR OTHERS, WITHOUT THE PRIOR WRITTEN EXPRESS CONSENT OF GZA, WILL BE AT THE USER'S SOLE RISK AND WITHOUT ANY RISK OR LIABILITY TO GZA.

FRANCIS MYERS RECREATION CENTER 5801 KINGSESSING AVENUE PHILADELPHIA, PENNSYLVANIA			
EXPLORATION LOCATION PLAN EXISTING CONDITIONS			
PREPARED BY: GZA GeoEnvironmental, Inc. Engineers and Scientists www.gza.com		PREPARED FOR: DIGSAU 340 NORTH 12TH STREET, SUITE 421 PHILADELPHIA, PENNSYLVANIA	
PROJ MGR: EP DESIGNED BY: EP DATE: JULY 2022	REVIEWED BY: EP DRAWN BY: AJP PROJECT NO.: 14.0079893.00	CHECKED BY: EH SCALE: AS SHOWN REVISION NO.: -	FIGURE 2A SHEET NO. 1 OF 2

© 2022 - GZA GeoEnvironmental, Inc. GZA\gza\philly\jobs\14.0079893\14.0079893\00-Exploration Location Plan.dwg [Proposed Conditions] July 25, 2022 - 10:09am alexander.perez

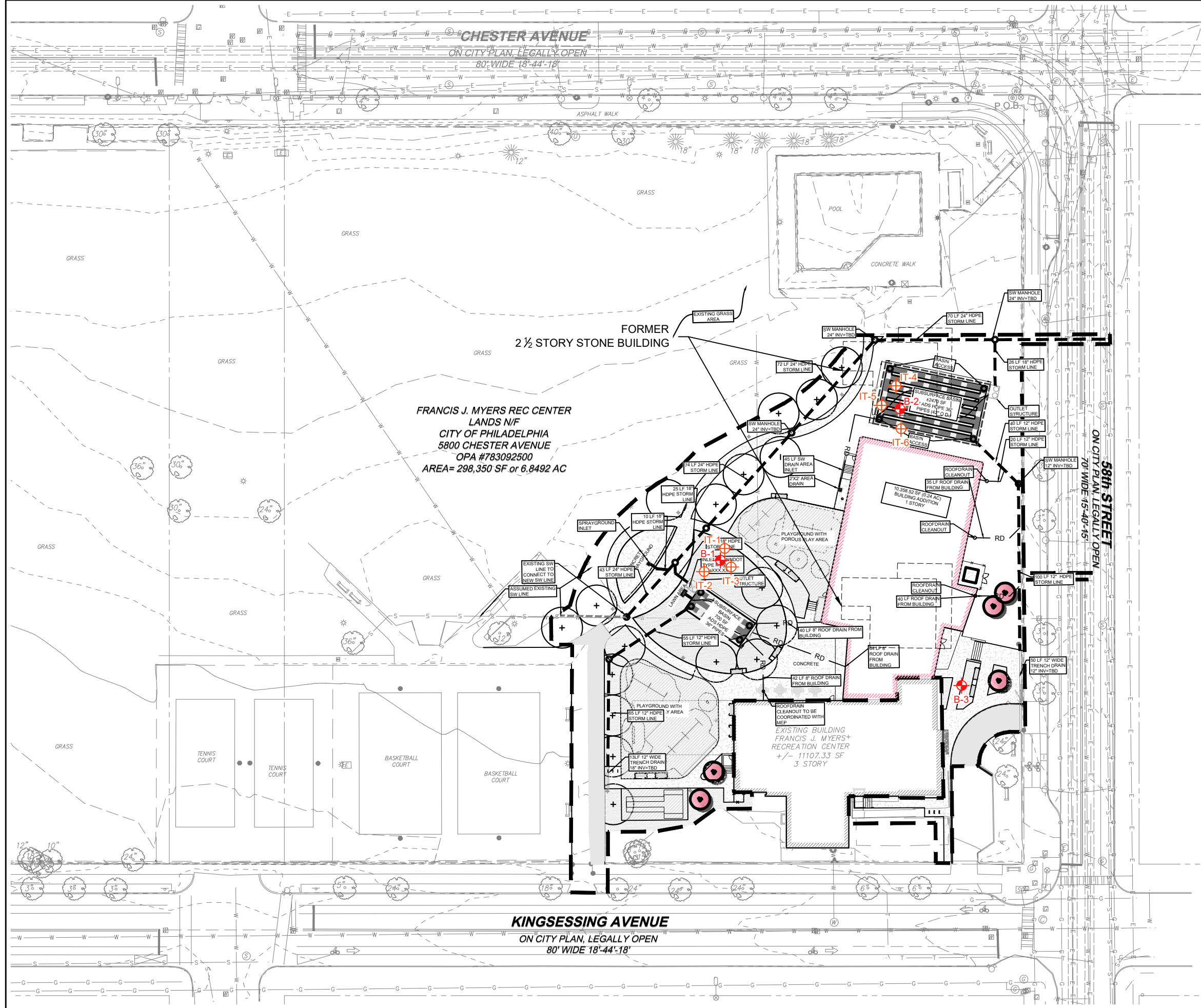

LEGEND

- GEOTECHNICAL SOIL BORING (FEBRUARY 2022)
- CASED BOREHOLE PERCOLATION TEST (FEBRUARY 2022)

SOURCE:

1. THE BASE PLANS WERE OBTAIN FROM ELECTRONIC FILES PROVIDED BY DIGSAU AND PREPARED BY DAVID MASON & ASSOCIATES ENTITLED:
 - SET FILE 2022-05-11_FJM-100%SD-CIVIL-SET.PDF, DATED 05/13/2022,
 - a. "EXISTING CONDITIONS PLAN", ORIGINAL SCALE: 1"=20', DRAWING NO.: C-100.
 - b. "SITE PLAN", ORIGINAL SCALE: 1"=20', DRAWING NO.: C-200.
 - c. "UTILITY PLAN", ORIGINAL SCALE: 1"=20', DRAWING NO.: C-400.
 - d. "GRADING PLAN", ORIGINAL SCALE: 1"=20', DRAWING NO.: C-600.

FORMER 2½ STORY BUILDINGS WERE TRACED FROM "SITE PLAN FOR DEMOLITION WORK AT FORMER PRESBYTERIAN ORPHANAGE", CITY OF PHILADELPHIA-DEPARTMENT OF RECREATION, MARCH 29 1963.

- THE LOCATION, AND ELEVATIONS OF THE BORINGS, AND INFILTRATION TEST LOCATIONS WERE APPROXIMATELY DETERMINED BY TAPE MEASUREMENTS AND LINE OF SIGHT FROM EXISTING SITE FEATURES. THE DATA SHOULD BE CONSIDERED ACCURATE ONLY TO THE DEGREE IMPLIED BY THE METHOD USED.

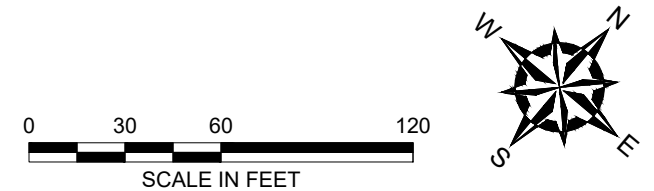

UNLESS SPECIFICALLY STATED BY WRITTEN AGREEMENT, THIS DRAWING IS THE SOLE PROPERTY OF GZA GEOENVIRONMENTAL, INC. (GZA). THE INFORMATION SHOWN ON THE DRAWING IS SOLELY FOR USE BY GZA'S CLIENT OR THE CLIENT'S DESIGNATED REPRESENTATIVE FOR THE SPECIFIC PROJECT AND LOCATION IDENTIFIED ON THE DRAWING. THE DRAWING SHALL NOT BE TRANSFERRED, REUSED, COPIED, OR ALTERED IN ANY MANNER FOR USE AT ANY OTHER LOCATION OR FOR ANY OTHER PURPOSE WITHOUT THE PRIOR WRITTEN CONSENT OF GZA. ANY TRANSFER, REUSE, OR MODIFICATION TO THE DRAWING BY THE CLIENT OR OTHERS, WITHOUT THE PRIOR WRITTEN EXPRESS CONSENT OF GZA, WILL BE AT THE USER'S SOLE RISK AND WITHOUT ANY RISK OR LIABILITY TO GZA.

FRANCIS MYERS RECREATION CENTER
 5801 KINGSESSING AVENUE
 PHILADELPHIA, PENNSYLVANIA

**EXPLORATION LOCATION PLAN
 PROPOSED CONDITIONS**

PREPARED BY: GZA GeoEnvironmental, Inc. Engineers and Scientists www.gza.com		PREPARED FOR: DIGSAU 340 NORTH 12TH STREET, SUITE 421 PHILADELPHIA, PENNSYLVANIA	
PROJ MGR: EP DESIGNED BY: EP DATE: JULY 2022	REVIEWED BY: EP DRAWN BY: AJP PROJECT NO.: 14.0079893.00	CHECKED BY: EH SCALE: AS SHOWN REVISION NO.: -	FIGURE 2B SHEET NO. 2 OF 2



Appendix A - Limitations



USE OF REPORT

1. GZA GeoEnvironmental, Inc. (GZA) prepared this report on behalf of, and for the exclusive use of our Client for the stated purpose(s) and location(s) identified in the Proposal for Services and/or Report. Use of this report, in whole or in part, at other locations, or for other purposes, may lead to inappropriate conclusions; and we do not accept any responsibility for the consequences of such use(s). Further, reliance by any party not expressly identified in the contract documents, for any use, without our prior written permission, shall be at that party's sole risk, and without any liability to GZA.

STANDARD OF CARE

2. GZA's findings and conclusions are based on the work conducted as part of the Scope of Services set forth in Proposal for Services and/or Report, and reflect our professional judgment. These findings and conclusions must be considered not as scientific or engineering certainties, but rather as our professional opinions concerning the limited data gathered during the course of our work. If conditions other than those described in this report are found at the subject location(s), or the design has been altered in any way, GZA shall be so notified and afforded the opportunity to revise the report, as appropriate, to reflect the unanticipated changed conditions .
3. GZA's services were performed using the degree of skill and care ordinarily exercised by qualified professionals performing the same type of services, at the same time, under similar conditions, at the same or a similar property. No warranty, expressed or implied, is made.
4. In conducting our work, GZA relied upon certain information made available by public agencies, Client and/or others. GZA did not attempt to independently verify the accuracy or completeness of that information. Inconsistencies in this information which we have noted, if any, are discussed in the Report.

SUBSURFACE CONDITIONS

5. The generalized soil profile(s) provided in our Report are based on widely-spaced subsurface explorations and are intended only to convey trends in subsurface conditions. The boundaries between strata are approximate and idealized, and were based on our assessment of subsurface conditions. The composition of strata, and the transitions between strata, may be more variable and more complex than indicated. For more specific information on soil conditions at a specific location refer to the exploration logs. The nature and extent of variations between these explorations may not become evident until further exploration or construction. If variations or other latent conditions then become evident, it will be necessary to reevaluate the conclusions and recommendations of this report.
6. In preparing this report, GZA relied on certain information provided by the Client, state and local officials, and other parties referenced therein which were made available to GZA at the time of our evaluation. GZA did not attempt to independently verify the accuracy or completeness of all information reviewed or received during the course of this evaluation.
7. Water level readings have been made in test holes (as described in this Report) and monitoring wells at the specified times and under the stated conditions. These data have been reviewed and interpretations have been made in this Report. Fluctuations in the level of the groundwater however occur due to temporal or spatial variations in areal recharge rates, soil heterogeneities, the presence of subsurface utilities, and/or natural or artificially induced perturbations. The water table encountered in the course of the work may differ from that indicated in the Report.
8. GZA's services did not include an assessment of the presence of oil or hazardous materials at the property. Consequently, we did not consider the potential impacts (if any) that contaminants in soil or groundwater may have on construction activities, or the use of structures on the property.



9. Recommendations for foundation drainage, waterproofing, and moisture control address the conventional geotechnical engineering aspects of seepage control. These recommendations may not preclude an environment that allows the infestation of mold or other biological pollutants.

COMPLIANCE WITH CODES AND REGULATIONS

10. We used reasonable care in identifying and interpreting applicable codes and regulations. These codes and regulations are subject to various, and possibly contradictory, interpretations. Compliance with codes and regulations by other parties is beyond our control.

COST ESTIMATES

11. Unless otherwise stated, our cost estimates are only for comparative and general planning purposes. These estimates may involve approximate quantity evaluations. Note that these quantity estimates are not intended to be sufficiently accurate to develop construction bids, or to predict the actual cost of work addressed in this Report. Further, since we have no control over either when the work will take place or the labor and material costs required to plan and execute the anticipated work, our cost estimates were made by relying on our experience, the experience of others, and other sources of readily available information. Actual costs may vary over time and could be significantly more, or less, than stated in the Report.

ADDITIONAL SERVICES

12. GZA recommends that we be retained to provide services during any future: site observations, design, implementation activities, construction and/or property development/redevelopment. This will allow us the opportunity to: i) observe conditions and compliance with our design concepts and opinions; ii) allow for changes in the event that conditions are other than anticipated; iii) provide modifications to our design; and iv) assess the consequences of changes in technologies and/or regulations.



Appendix B – Test Boring Logs

LOG KEY



GZA
Geo Environmental, Inc.
Engineers and Scientists

BURMISTER SOIL CLASSIFICATION

COMPONENT	NAME	PROPORTIONAL TERM	PERCENT BY WEIGHT	IDENTIFICATION OF FINES		
				Material	PI	Atterberg Thread Dia.
MAJOR	GRAVEL, SAND, FINES*		>50	SILT	0	Cannot Roll
Minor	Gravel, Sand, Fines*	and	35 - 50	Clayey SILT	1-5	1/4"
		some	20-35	SILT & CLAY	5-10	1/8"
		little	10-20	CLAY & SILT	10-20	1/16"
		trace	0-10	Silty CLAY	20-40	1/32"
				CLAY	>40	1/64"

*See identification of fines table.

GRADATION DESIGNATION	PROPORTION OF COMPONENT	PLASTIC SOILS		GRAVEL & SAND	
		Consistency	Blows/Ft. SPT N-Value	Density	Blows/Ft. SPT N-Value
Fine to coarse	All fractions > 10%	Very Soft	< 2	Very Loose	< 4
Medium to coarse	<10% fine	Soft	2 - 4	Loose	4 - 10
Fine to medium	<10% coarse	Medium Stiff	4 - 8	Medium Dense	10 - 30
Coarse	<10% fine and medium	Stiff	8 - 15	Dense	30 - 50
Medium	<10% coarse and fine	Very Stiff	15 - 30	Very Dense	> 50
Fine	<10% coarse and medium	Hard	>30		

UNIFIED SOIL CLASSIFICATION SYSTEM (USCS) (ASTM D 2487)

MAJOR DIVISIONS	Group Symbols
Coarse Grained Soils More than 50% of material larger than No. 200 sieve.	Gravel More than 50% larger than No. 4 sieve.
	Clean Gravels (Little or no fines)
	Gravels with Fines (Appreciable amount of fines)
	Sand More than 50% smaller than No. 4 sieve.
Fine Grained Soils More than 50% of material smaller than No. 200 sieve.	Clean Sands (Little or no fines)
	Sands with Fines (Appreciable amount of fines)
	Silts and Clays Liquid Limit <50
	Silts and Clays Liquid Limit >50
Highly Organic Soils	Pt

ORGANIC SOIL CLASSIFICATION

Fibrous PEAT (Pt) - Lightweight, spongy, mostly visible organic matter, water squeezes readily from sample. Typically near top of deposit.
 Fine Grained PEAT (Pt) - Lightweight, spongy, little visible organic matter, water squeezes readily from sample. Typically below fibrous peat.
 Organic Silt (OL) - Typically gray to dark gray, often has strong H₂S odor. Typically contains shells or shell fragments. Lightweight. Usually found near coastal regions. May contain wide range of sand fractions.
 Organic Clay (OH) - Typically gray to dark gray, high plasticity. Usually found near coastal regions. May contain wide range of sand fractions. Need organic content test for final identification.

ABBREVIATIONS

MR = Mud Rotary	Tv = Field Vane Shear Test (Torvane) Shear Strength
HSA = Hollow Stem Auger	PP = Pocket Penetrometer Shear Strength
SSA = Solid Stem Auger	PI = Plasticity Index
SS = Split Spoon Sampler	Wn = Moisture Content
U = Undisturbed Sample (Shelby Tube)	CO = Consolidation
MC = Modified California Sampler	UC = Unconfined Compression Test
V = Vibracore	UU = Unconsolidated Undrained (Triaxial) Test
M = Macrocore	SI = Sieve Analysis
	DS = Direct Shear
USCS = Unified Soil Classification System (ASTM D2487)	PID = Photoionization Detector
NYCBC = New York City Building Code	ppm = Parts Per Million
WOR = Weight of Rods	REC = Recovery
WOH= Weight of Hammer	RQD = Rock Quality Designation
SPT = Standard Penetration Test (ASTM D1586)	▼ = Measured Water Level
N-Value = Cumulative number of uncorrected blows for the middle two six-inch intervals (blows/foot).	

TEST BORING LOG



GZA
GeoEnvironmental, Inc.
Engineers and Scientists

DIGSAU
Francis Myers Recreation Center
5801 Kingsessing Avenue
Philadelphia, Pennsylvania

EXPLORATION NO.: B-1
SHEET: 1 of 1
PROJECT NO: 14.0079893.00
REVIEWED BY: E. Hanna

Logged By: E. Phelps
Drilling Co.: Cascade Remediation Services LLC
Foreman: Brandon Pizzuti

Type of Rig: GeoProbe
Rig Model: 7822DT
Drilling Method: Direct Push

Boring Location: See Plan
Ground Surface Elev. (ft.): 78.6
Final Boring Depth (ft.): 19.5
Date Start - Finish: 6/27/2022 - 6/27/2022

H. Datum: N/A
V. Datum: NAVD88

Hammer Type: Automatic Hammer
Hammer Weight (lb.): 140
Hammer Fall (in.): 30
Auger or Casing O.D./I.D Dia (in.): 3.25/2.78

Sampler Type: SS
Sampler O.D. (in.): 2.0
Sampler Length (in.): 24
Rock Core Size: N/A

Groundwater Depth (ft.)

Date	Time	Water Depth	Stab. Time
06/27/22	12:16	18.4	15 min

Depth (ft)	Casing Blows/ Core Rate	Sample						SPT Value	Sample Description and Identification (Modified Burmister Procedure)	Remark	Field Test Data	Depth (ft.)	Stratum Description	Elev. (ft.)		
		No.	Depth (ft.)	Pen. (in)	Rec. (in)	Blows (per 6 in.)										
5		S-1	0-0.33 0.33-2	24	18	4 3 4 3	7	: Top 4" Asphalt Pavement S-1 : 0-7": Gray and brown, fine to coarse SAND, little Silt, trace fine Gravel (SM) [FILL] (MC = 10.7%) 7-18": Medium stiff, orange brown, SILT, moist [FILL] (MC = 22.3%)	1		0.33	ASPHALT	78.3			
		S-2	2-4	24	20	5 5 8 10	13	S-2 : Medium dense, yellowish brown, fine to coarse SAND, some Silt, moist (SM) (MC = 14.4%)			2	FILL	76.6			
		S-3	4-6	24	20	6 7 7 7	14	S-3 : Medium dense, yellowish brown, fine to medium SAND, little Silt, trace fine Gravel, moist (SP-SM) (MC = 8.2%)								
		S-4	6-8	24	18	8 6 3 3	9	S-4 : Loose, yellowish brown and dark brown, fine to medium SAND, some Silt and Clay, trace fine Gravel, moist (SM) (MC = 14.3%)						SILTY SAND (SM)		
		S-5	8-10	24	16	4 4 7 6	11	S-5 : Medium dense, yellowish brown, brown, dark reddish brown, fine to coarse SAND, some Silt and Clay, little fine Gravel, moist (SM) (MC = 16.5%)								
		S-6	13-15	24	20	5 15 18 22	33	S-6 : Dense, yellowish brown, gray, white, WEATHERED ROCK, fine to medium SAND, little Silt, moist (SP-SM) (MC = 14.8%)				13		65.6		
		S-7	15-17	24	20	11 23 19 29	42	S-7 : Dense, gray, white, yellow brown, brown, WEATHERED ROCK, fine to medium SAND with mica flakes, little Silt, moist (SM) (MC = 9.6%)							WEATHERED ROCK (SM)	
		S-8	17.5-19.5	24	20	28 34 40 50	74	S-8 : Very dense, gray, white, brown, WEATHERED ROCK, fine to medium SAND, trace mica flakes, little Silt, moist (SM) (MC = 8.9%)				19.5		59.1		
20								End of exploration at 19.5 feet.								

REMARKS
1 - Stratification lines represent approximate boundaries between soil types, transitions may be gradual. Water level readings have been made at times and under conditions stated. Fluctuations of groundwater may occur due to factors other than those present at the time measurements were made.

See Log Key for explanation of sample description and identification procedures. Stratification lines represent approximate boundaries between soil and bedrock types. Actual transitions may be gradual. Water level readings have been made at the times and under the conditions stated. Fluctuations of groundwater may occur due to other factors than those present at the times the measurements were made.

Exploration No.: B-1

TEST BORING LOG



GZA
GeoEnvironmental, Inc.
Engineers and Scientists

DIGSAU
Francis Myers Recreation Center
5801 Kingsessing Avenue
Philadelphia, Pennsylvania

EXPLORATION NO.: B-2
SHEET: 1 of 1
PROJECT NO: 14.0079893.00
REVIEWED BY: E. Hanna

Logged By: E. Phelps
Drilling Co.: Cascade Remediation Services LLC
Foreman: Brandon Pizzuti

Type of Rig: GeoProbe
Rig Model: 7822DT
Drilling Method: Direct Push

Boring Location: See Plan
Ground Surface Elev. (ft.): 76.8
Final Boring Depth (ft.): 11.8
Date Start - Finish: 6/27/2022 - 6/27/2022

H. Datum: N/A
V. Datum: NAVD88

Hammer Type: Automatic Hammer
Hammer Weight (lb.): 140
Hammer Fall (in.): 30
Auger or Casing O.D./I.D Dia (in.): 3.25/2.78

Sampler Type: SS
Sampler O.D. (in.): 2.0
Sampler Length (in.): 24
Rock Core Size: N/A

Groundwater Depth (ft.)

Date	Time	Water Depth	Stab. Time
		Groundwater Not Encountered	

Depth (ft)	Casing Blows/ Core Rate	Sample						SPT Value	Sample Description and Identification (Modified Burmister Procedure)	Remark	Field Test Data	Depth (ft.)	Stratum Description	Elev. (ft.)	
		No.	Depth (ft.)	Pen. (in)	Rec. (in)	Blows (per 6 in.)									
5		S-1	0-2	24	9	2 7 5 4	12	S-1 : 0"-3": Medium dense, grayish brown, fine SAND, little Silt, roots, grass, slightly moist (Topsoil)	1		0.25	TOPSOIL	76.6		
		S-2	2-4	24	16	8 4 3 2	7	3"-9": Medium dense, grayish brown, fine SAND, little Silt, trace roots, slightly moist [FILL] (MC = 22.4%) S-2 : Loose, brown, fine to coarse SAND, some fine to medium Gravel, trace Silt, brick fragments, moist (SW-SM) [FILL] (MC = 12.9%)					FILL		
		S-3	4-6	24	13	5 4 4 4	8	S-3 : 0"-7": Loose, brown, fine to medium GRAVEL and fine to coarse SAND, little Clayey Silt, brick fragments, moist (MC = 13.6%) (GM) [FILL]				5		71.8	
		S-4	6-8	24	20	2 4 4 5	8	7"-13": Loose, yellowish brown, fine SAND and SILT, moist (MC = 34.4%) (SM) S-4 : Loose, reddish brown, fine to medium SAND and Clayey SILT, mica specks, moist (SM) (MC = 32.8%)				8		68.8	
		S-5	8-10	24	20	7 9 11 16	20	S-5 : Medium dense, gray and reddish brown, apparent WEATHERED ROCK, fine to medium SAND, little Silt, mica specks, moist (SM) (MC = 12.2%)							
		S-6	10-11.8	22	20	40 50 62 50/4"	R	S-6 : Very dense, gray and reddish brown, WEATHERED ROCK, fine to medium SAND, little Silt, mica specks, moist (MC = 7.3%) (SM)							
								End of exploration at 11.8 feet.	2		11.8		65.0		

REMARKS

1 - Stratification lines represent approximate boundaries between soil types, transitions may be gradual. Water level readings have been made at times and under conditions stated. Fluctuations of groundwater may occur due to factors other than those present.
2 - Split spoon refusal and direct push casing refusal.

See Log Key for explanation of sample description and identification procedures. Stratification lines represent approximate boundaries between soil and bedrock types. Actual transitions may be gradual. Water level readings have been made at the times and under the conditions stated. Fluctuations of groundwater may occur due to other factors than those present at the times the measurements were made.

Exploration No.:
B-2

TEST BORING LOG



GZA
GeoEnvironmental, Inc.
Engineers and Scientists

DIGSAU
Francis Myers Recreation Center
5801 Kingsessing Avenue
Philadelphia, Pennsylvania

EXPLORATION NO.: B-3
SHEET: 1 of 1
PROJECT NO: 14.0079893.00
REVIEWED BY: E. Hanna

Logged By: E. Phelps
Drilling Co.: Cascade Remediation Services LLC
Foreman: Brandon Pizzuti

Type of Rig: GeoProbe
Rig Model: 7822DT
Drilling Method: Direct Push

Boring Location: See Plan
Ground Surface Elev. (ft.): 80.5
Final Boring Depth (ft.): 20
Date Start - Finish: 6/27/2022 - 6/27/2022

H. Datum: N/A
V. Datum: NAVD88

Hammer Type: Automatic Hammer
Hammer Weight (lb.): 140
Hammer Fall (in.): 30
Auger or Casing O.D./I.D Dia (in.): 3.25/2.78

Sampler Type: SS
Sampler O.D. (in.): 2.0
Sampler Length (in.): 24
Rock Core Size: N/A

Groundwater Depth (ft.)

Date	Time	Water Depth	Stab. Time
		Groundwater Not Encountered	

Depth (ft)	Casing Blows/ Core Rate	Sample						SPT Value	Sample Description and Identification (Modified Burmister Procedure)	Remark	Field Test Data	Depth (ft.)	Stratum Description	Elev. (ft.)
		No.	Depth (ft.)	Pen. (in)	Rec. (in)	Blows (per 6 in.)								
5		S-1	0-0.33 0.33-2	24	14	4 4 2 2	6	: 0"-4": Asphalt Pavement S-1 : 4"-14": Loose, white, light gray, coarse to fine GRAVEL, some fine to coarse Sand, dry (GW) [FILL]	1		0.33	ASPHALT	80.2	
		S-2NR	2-4	24	0	4 4 5 7	9	S-2NR : No Recovery	2		1.5	GRAVEL BASE COURSE	79.0	
		S-2	4-6	24	20	5 7 7 8	14	S-2 : Medium dense, yellowish red, fine to coarse SAND, some Silt, trace coarse Sand and fine gravel-sized Quartz Fragments, moist (SM)					SILTY SAND (SM)	
		S-3	6-8	24	20	6 5 5 5	10	S-3 : Loose, yellowish red, fine to coarse SAND, little Silt, moist (SM)						
		S-4	8-10	24	16	6 7 8 8	15	S-4 : 0"- 6": Medium dense, yellowish brown, fine to coarse SAND, little Silt, trace fine Gravel, moist (SW-SM) 6"-9": Medium dense, yellowish brown, fine to coarse SAND and SILT, moist (SM)			9			71.5
		S-5	13-15	24	18	8 9 13 16	22	S-5 : Medium dense, brown, apparent WEATHERED ROCK, fine to medium SAND, little Silt, mica specks, moist (SP-SM) (MC = 15.2%)			13			67.5
		S-6	15-17	24	22	13 12 13 13	25	S-6 : Medium dense, reddish brown, apparent WEATHERED ROCK, fine to medium SAND, little Silt, mica specks, moist (SP-SM)						WEATHERED ROCK (SP-SM)
20		S-7	18-20	24	20	7 9 13 14	22	S-7 : Medium dense, reddish brown, apparent WEATHERED ROCK, fine to medium GRAVEL and fine to coarse SAND, some Silt, moist (GM)			20			60.5
								End of exploration at 20 feet.						

REMARKS
1 - Stratification lines represent approximate boundaries between soil types, transitions may be gradual. Water level readings have been made at times and under conditions stated. Fluctuations of groundwater may occur due to factors other than those present
2 - No sample recovery. Possibly driving on a large gravel piece or cobble.

See Log Key for explanation of sample description and identification procedures. Stratification lines represent approximate boundaries between soil and bedrock types. Actual transitions may be gradual. Water level readings have been made at the times and under the conditions stated. Fluctuations of groundwater may occur due to other factors than those present at the times the measurements were made.

Exploration No.:
B-3

GZA TEMPLATE TEST BORING; 7/27/2022; 9:20:53 PM



Appendix C – Cased Borehole Percolation Test Logs

PWD Stormwater Plan Review Infiltration Testing Log

Version 1 7/1/2015

Project Name: Francis Myers Recreation Center **Date:** 28-Jun-22
Project Address: 5801 Kingsessing Avenue **Weather:** 80s Sunny
Testing Company: GZA GeoEnvironmental, Inc. **Tester's Name:** E. Phelps
Phone Number: _____ **Email Address:** edward.phelps@gza.com
Test Number: IT-1 **Test Pit/Boring Hole Number:** B-1 **Test Method:** PWD Cased Borehole
Test Depth (feet): 6.3' **Surface Elevation (feet):** 78.5 +/- **Instrument Diameter (inches):** 4

Soil Characterization

Depth (feet):	Soil Texture:	Limiting Layers Type and Depth (feet):
0-2	FILL- 1' Sand, 1' Silt	1' - 2' Silt
2 - 13	Silty Sand	
13 - 19.5	Weathered Rock - Sand, little Silt	

Presoak

Time:	Time Interval:	Measurement, (feet):	Drop in water level, (feet):	Remarks:
11:50	0	5.10	-	
12:02	12 (of 30)	5.60	0.5	Dropped to 5.6'. Refilled to 5.10.
12:20	30	5.19	0.09	
12:50	30	5.20	0.01	Refilled to 5.10 for test

Infiltration Testing

Time:	Time Interval (10 or 30 minutes):	Measurement, (feet):	Drop in water level, (feet):	Infiltration rate (inches per hour):	Remarks:
12:50	0	5.10	-		
13:20	30	5.17	0.07	1.68	
13:50	30	5.21	0.04	0.96	
14:20	30	5.21	0.00	0.00	
14:50	30	5.21	0.00	0.00	
15:20	30	5.21	0.00	0.00	
15:50	30	5.21	0.00	0.00	

Stabilized Infiltration Testing Rate (inches per hour):

0.00

PWD Stormwater Plan Review Infiltration Testing Log

Version 1 7/1/2015

Project Name: Francis Myers Recreation Center **Date:** 28-Jun-22
Project Address: 5801 Kingsessing Avenue **Weather:** 80s Sunny
Testing Company: GZA GeoEnvironmental, Inc. **Tester's Name:** E. Phelps
Phone Number: _____ **Email Address:** edward.phelps@gza.com
Test Number: IT-2 **Test Pit/Boring Hole Number:** B-1 **Test Method:** PWD Cased Borehole
Test Depth (feet): 6.5' **Surface Elevation (feet):** 78.5 +/- **Instrument Diameter (inches):** 4

Soil Characterization

Depth (feet):	Soil Texture:	Limiting Layers Type and Depth (feet):
0-2	FILL- 1' Sand, 1' Silt	1' - 2' Silt
2 - 13	Silty Sand	
13 - 19.5	Weathered Rock - Sand, little Silt	

Presoak

Time:	Time Interval:	Measurement, (feet):	Drop in water level, (feet):	Remarks:
9:41	0	5.55	-	
9:56	15 (of 30)	6.55	1	Dropped to 6.55. Refilled to 5.55.
10:11	30	6.09	0.54	Dropped to 6.09. Refilled to 5.55.
10:17	6 (of 30)	6.05	0.50	Dropped to 6.05. Refilled to 5.55. 0.5/6 min
10:27	16 (of 30)	6.05	0.50	Dropped to 6.05. Refilled to 5.55. 0.5/10 min
10:41	30	6.05	0.50	Dropped to 6.05. Refilled to 5.55. 0.5/14 min

Infiltration Testing

Time:	Time Interval (10 or 30 minutes):	Measurement, (feet):	Drop in water level, (feet):	Infiltration rate (inches per hour):	Remarks:
10:41	0	5.55	-		Refilled to 5.55' for test
10:51	10	5.90	0.35	25.20	Refilled to 5.55'
11:01	10	5.93	0.38	27.36	
11:11	10	6.15	0.22	15.84	Refilled to 5.55'
11:21	10	6.01	0.46	33.12	Refilled to 5.55'
11:36	10	6.03	0.48	34.56	Refilled to 5.55'
11:46	10	6.00	0.45	32.40	Refilled to 5.35'
11:56	10	5.90	0.55	39.6	Refilled to 4.85'
12:06	10	5.37	0.52	37.44	
Stabilized Infiltration Testing Rate (inches per hour):				37.44	

PWD Stormwater Plan Review Infiltration Testing Log

Version 1 7/1/2015

Project Name: Francis Myers Recreation Center **Date:** 28-Jun-22
Project Address: 5801 Kingsessing Avenue **Weather:** 80s Sunny
Testing Company: GZA GeoEnvironmental, Inc. **Tester's Name:** E. Phelps
Phone Number: _____ **Email Address:** edward.phelps@gza.com
Test Number: IT-3 **Test Pit/Boring Hole Number:** B-1 **Test Method:** PWD Cased Borehole
Test Depth (feet): 6.5' **Surface Elevation (feet):** 78.5 +/- **Instrument Diameter (inches):** 4

Soil Characterization

Depth (feet):	Soil Texture:	Limiting Layers Type and Depth (feet):
0-2	FILL- 1' Sand, 1' Silt	1' - 2' Silt
2 - 13	Silty Sand	
13 - 19.5	Weathered Rock - Sand, little Silt	

Presoak

Time:	Time Interval:	Measurement, (feet):	Drop in water level, (feet):	Remarks:
10:45	0	5.40	-	
10:53	8 (of 30)	6.10	0.7	Dropped to 6.1'. Refilled to 4.75.
11:03	18 (of 30)	5.75	1.03	Dropped to 5.78'. Refilled to 4.75.
11:15	30	6.21	1.46	Dropped to 6.21'. Refilled to 5.08'.
11:21	6 (of 30)	5.75	0.67	Dropped to 5.75'. Refilled to 5.5'.
11:27	12 (of 30)	5.75	0.25	Dropped to 5.75'. Refilled to 5.5'.
11:37	22 (of 30)	6.00	0.50	Dropped to 6'. Refilled to 5.5'.
11:45	30	6.17	0.58	Dropped to 6.17'. Refilled to 5.4'.

Infiltration Testing

Time:	Time Interval (10 or 30 minutes):	Measurement, (feet):	Drop in water level, (feet):	Infiltration rate (inches per hour):	Remarks:
11:50	0	5.40	-		
12:00	10	6.10	0.70	50.40	Filled to 5' 5"
12:10	10	5.92	0.50	36.00	Filled to 5' 3/4"
12:20	10	5.84	0.78	56.16	Filled to 5' 4 1/2"
12:30	10	5.77	0.40	28.80	Filled to 5' 5"
12:40	10	5.88	0.46	33.12	Filled to 5' 4 1/2"
12:50	10	5.86	0.48	34.56	Filled to 5' 5 1/4"
13:00	10	5.83	0.38	27.36	
13:10	10	6.41	0.58	41.76	
Stabilized Infiltration Testing Rate (inches per hour):				41.76	

PWD Stormwater Plan Review Infiltration Testing Log

Version 1 7/1/2015

Project Name: Francis Myers Recreation Center **Date:** 29-Jun-22
Project Address: 5801 Kingsessing Avenue **Weather:** 80s Sunny
Testing Company: GZA GeoEnvironmental, Inc. **Tester's Name:** E. Phelps
Phone Number: _____ **Email Address:** edward.phelps@gza.com
Test Number: IT-4 **Test Pit/Boring Hole Number:** B-2 **Test Method:** PWD Cased Borehole
Test Depth (feet): 6.5' **Surface Elevation (feet):** 76.5 +/- **Instrument Diameter (inches):** 4

Soil Characterization

Depth (feet):	Soil Texture:	Limiting Layers Type and Depth (feet):
0-5	FILL - Sand, varying Gravel and Silt	
5-8	Sand and Silt	
8-11.8	Weathered Rock - Sand, little Silt	
11.8	Apparent Top of Rock	

Presoak

Time:	Time Interval:	Measurement, (feet):	Drop in water level, (feet):	Remarks:
12:21	0	5.35	-	
12:32	11 (of 30)	5.87	6.24	Dropped to 5.87'. Refilled to 5.35'.
12:51	30	5.87	6.24	Dropped to 5.87'. Refilled to 5.3'.
13:21	30	6.40	1.10	Dropped to 6.4'. Refilled to 5.47'.

Infiltration Testing

Time:	Time Interval (10 or 30 minutes):	Measurement, (feet):	Drop in water level, (feet):	Infiltration rate (inches per hour):	Remarks:
13:25	0	5.47	-		
13:35	10	5.80	0.33	23.76	
13:45	10	6.16	0.36	25.92	Refilled to 5.37
13:55	10	5.79	0.42	30.24	
14:05	10	6.15	0.36	25.92	Refilled to 5.51
14:15	10	5.73	0.22	15.84	
14:25	10	5.94	0.21	15.12	
14:35	10	6.16	0.22	15.84	Refilled to 5.55
14:45	10	5.85	0.3	21.6	

Stabilized Infiltration Testing Rate (inches per hour):

15.84

PWD Stormwater Plan Review Infiltration Testing Log

Version 1 7/1/2015

Project Name: Francis Myers Recreation Center **Date:** 29-Jun-22
Project Address: 5801 Kingsessing Avenue **Weather:** 80s Sunny
Testing Company: GZA GeoEnvironmental, Inc. **Tester's Name:** E. Phelps
Phone Number: 215-871-9398 **Email Address:** edward.phelps@gza.com
Test Number: IT-5 **Test Pit/Boring Hole Number:** B-2 **Test Method:** PWD Cased Borehole
Test Depth (feet): 7' **Surface Elevation (feet):** 77+/- **Instrument Diameter (inches):** 4

Soil Characterization

Depth (feet):	Soil Texture:	Limiting Layers Type and Depth (feet):
0-5	FILL - Sand, varying Gravel and Silt	
5-8	Sand and Silt	
8-11.8	Weathered Rock - Sand, little Silt	
11.8	Apparent Top of Rock	

Presoak

Time:	Time Interval:	Measurement, (feet):	Drop in water level, (feet):	Remarks:
10:16	0	5.80	-	
10:30	14 (of 30)	6.30	0.5	Dropped to 6.3'. Refilled to 5.2'.
10:46	30	6.12	0.92	Dropped to 6.12. Refilled to 5.7'
11:16	30	6.56	0.86	Dropped to 6.56. Refilled to 5.80'.

Infiltration Testing

Time:	Time Interval (10 or 30 minutes):	Measurement, (feet):	Drop in water level, (feet):	Infiltration rate (inches per hour):	Remarks:
11:16	0	5.80	-		
11:26	10	6.08	0.28	20.16	
11:36	10	6.30	0.22	15.84	refilled to 5.80
11:46	10	6.50	0.70	50.40	refilled to 5.80
11:56	10	6.15	0.35	25.20	
12:06	10	6.25	0.10	7.20	refilled to 5.70
12:16	10	5.79	0.09	6.48	
12:26	10	5.88	0.09	6.48	
12:36	10	5.90	0.02	1.44	

Stabilized Infiltration Testing Rate (inches per hour):

1.44

PWD Stormwater Plan Review Infiltration Testing Log

Version 1 7/1/2015

Project Name: Francis Myers Recreation Center **Date:** 29-Jun-22
Project Address: 5801 Kingsessing Avenue **Weather:** 80s Sunny
Testing Company: GZA GeoEnvironmental, Inc. **Tester's Name:** E. Phelps
Phone Number: 215-871-9398 **Email Address:** edward.phelps@gza.com
Test Number: IT-6 **Test Pit/Boring Hole Number:** B-2 **Test Method:** PWD Cased Borehole
Test Depth (feet): 7' **Surface Elevation (feet):** 77+/- **Instrument Diameter (inches):** 4

Soil Characterization

Depth (feet):	Soil Texture:	Limiting Layers Type and Depth (feet):
0-5	FILL - Sand, varying Gravel and Silt	
5-8	Sand and Silt	
8-11.8	Weathered Rock - Sand, little Silt	
11.8	Apparent Top of Rock	

Presoak

Time:	Time Interval:	Measurement, (feet):	Drop in water level, (feet):	Remarks:
9:22	0	5.50	-	
9:52	30	5.99	0.49	Dropped to 5.99'. Refilled to 5.79'.
10:22	30	6.17	0.18	Dropped to 6.17'. Refilled 5.72'.

Infiltration Testing

Time:	Time Interval (10 or 30 minutes):	Measurement, (feet):	Drop in water level, (feet):	Infiltration rate (inches per hour):	Remarks:
10:22	0	5.72	-		
10:32	10	5.97	0.25	18.00	
10:42	10	6.10	0.13	9.36	
10:52	10	6.24	0.14	10.08	Refilled to 5.79
11:02	10	5.92	0.13	9.36	
11:12	10	6.10	0.18	12.96	
11:22	10	6.20	0.10	7.2	
11:32	10	6.30	0.1	7.2	Refilled to 5.80
11:42	10	6.0	0.2	14.4	

Stabilized Infiltration Testing Rate (inches per hour):

7.20



Appendix D – Laboratory Testing Results

Gradation Curve(s)

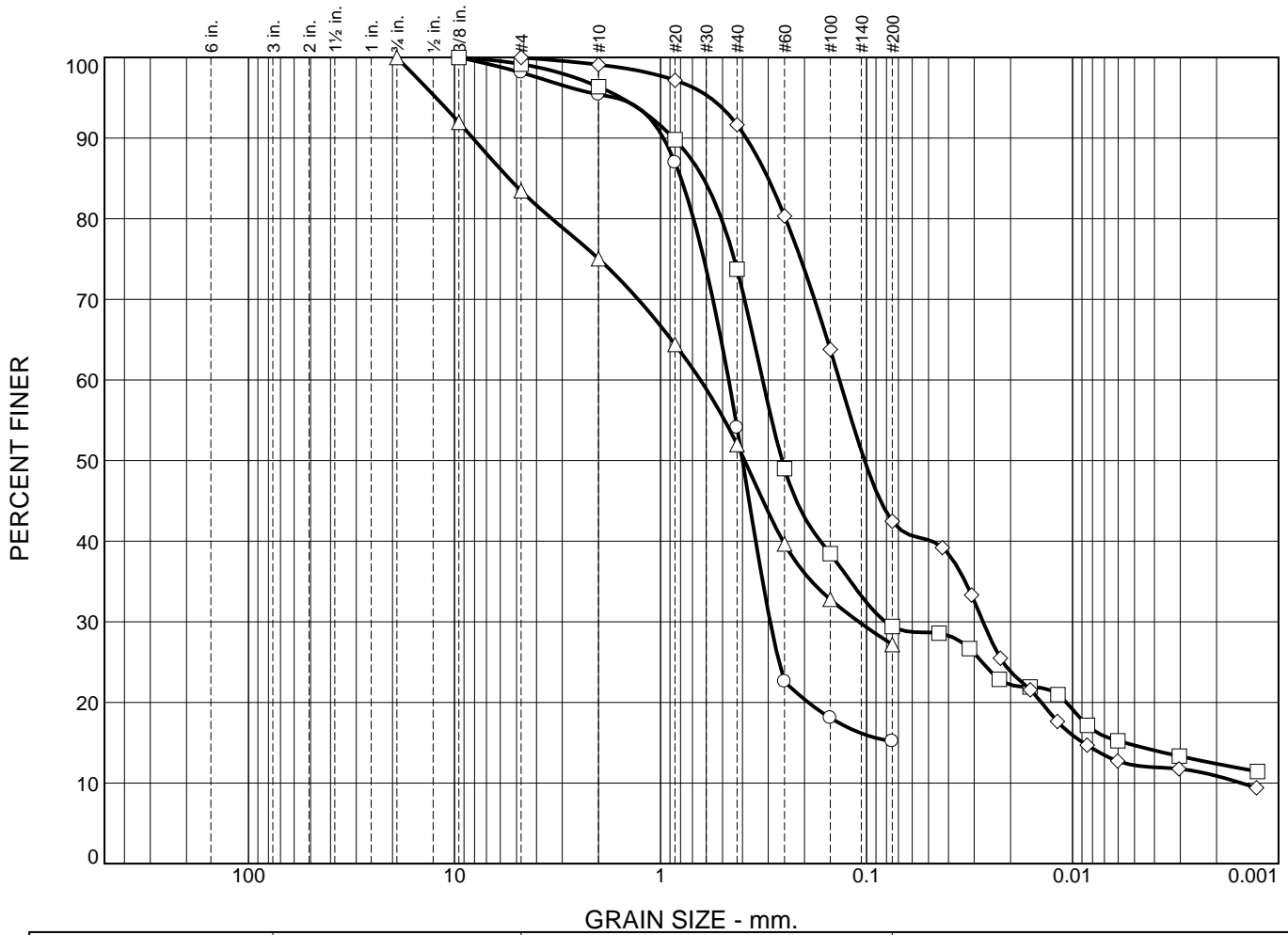

	% Cobbles	% Gravel		% Sand			% Fines	
		Coarse	Fine	Coarse	Medium	Fine	Silt	Clay
○	0.0	0.0	1.9	2.7	41.3	38.9	15.2	
□	0.0	0.0	0.8	2.8	22.7	44.3	14.7	14.7
△	0.0	0.0	16.5	8.5	23.0	24.8	27.2	
◇	0.0	0.0	0.0	0.9	7.4	49.2	30.3	12.2

SOIL DATA					
SYMBOL	SOURCE	SAMPLE NO.	DEPTH (ft.)	Material Description	USCS
○	B-1	S3	4-6	Fine to medium Sand, little Silt, trace fine Gravel (MC=8.2%)	SM
□	B-1	S4	6-8	Fine to medium Sand, some Silt, trace fine Gravel (MC=14.3%)	SM
△	B-1	S5	8-10	Fine to coarse Sand, some Silt, little fine Gravel (MC=16.5%)	SM
◇	B-2	S4	6-8	Fine to medium Sand, and Silt (MC=32.8%)	SM

Melick-Tully & Associates
a Division of GZA GeoEnvironmental, Inc.
South Bound Brook, NJ

Client: DIGSAU
Project: Francis Myers Recreation Center
Project No.: 14.0079893.00

Plate

Gradation Curve(s)



	% Cobbles	% Gravel		% Sand			% Fines	
		Coarse	Fine	Coarse	Medium	Fine	Silt	Clay
○	0.0	0.0	0.0	0.4	16.6	63.1	19.9	
□	0.0	0.0	0.0	0.3	43.4	44.5	11.8	

SOIL DATA					
SYMBOL	SOURCE	SAMPLE NO.	DEPTH (ft.)	Material Description	USCS
○	B-2	S5	8-10	Fine to medium Sand, little Silt (MC=12.2%)	SM
□	B-3	S6	13-15	Fine to medium Sand, little Silt (MC=15.2%)	SP-SM



Appendix E – East Coast Geophysical Report



501 Cambria Avenue, Suite 281, Bensalem, PA 19020
215-366-7389
eastcoastgeophysics.com

Date:

06/27/2022

Site Location:

5801 Kingessing Ave, Philadelphia, PA

Attention:

GZA

1515 Market Street, Suite 945 | Philadelphia, PA 19130

Regards:

Tyler Doratt

East Coast Geophysics Inc.

501 Cambria Avenue Suite 281, Bensalem, Pennsylvania, 19020

1. BACKGROUND AND PROJECT OBJECTIVES

5801 Kingessing Ave is currently occupied by Francis Myers Recreation. The survey will take place at client specified areas. Surface conditions consistent of asphalt, concrete and reinforced concrete.

Site project objectives are:

- Locate all detectable underground utilities adjacent to the client proposed boring locations.

2. EQUIPMENT

This project used the following equipment to perform the geophysical survey on the property.

- *GSSI SIR-3000 Cart Mounted Ground Penetrating Radar System*

Ground Penetrating Radar is a non-invasive geophysical method in which electromagnetic pulses probe the subsurface, allowing targets to be imaged in real time. The EM pulses that are transmitted into the subsurface are reflected from various interfaces within the ground, including soil horizons, ground water, and manmade features such as underground storage tanks and utilities. The GPR antenna consists of a transmitter, which is used to create the EM pulse, and a receiver which collects returning signals. The high frequency waves created by the antenna can be generated in a range of 10 MHz to 2.6 GHz. The frequency of the antenna will vary the depth of penetrations, signal clarity, and attenuation into the subsurface. The antenna used for general field work by ECG is 400 MHz; this frequency range has the capability to transmit to a depth of up to 10 feet below ground surface. Surface and subsurface conditions can greatly reduce the effective depth of the signal penetration; these conditions include conductive soils, slag/fill material and standing water.

- *Radiodetection RD7000+*

RD7000 is an advanced high-range precision utility detector capable of detecting utilities up to 15 feet below ground surface. The RD7000+ has the capability of locating a variety of pipes and cables using either passive or active modes. Passive signals can be traced with only the transmitter using “natural” signals present in many conductors. These signals can be generated from an array of sources including power cables, power system return currents, and long wave radio frequencies. **Active** signals are known AC frequencies induced onto a target pipe or cable. User induced signals can help positively identify lines throughout areas of congested utilities.

- *Fisher TW-6 Pipe and Cable Locator*

The Fisher TW-6 Pipe and cable locator uses electromagnetic induction to locate conductive materials, such as manholes, tanks, pipes, cables, and other metallic materials in the subsurface. The transmitter generates an AC current which produces an electromagnetic field similar to a dipole magnet. When the transmitter passes over a conductive feature, the generated electromagnetic field becomes distorted as a result of the interference with the natural electromagnetic field created by the conductive feature. The distortion of the generated field is detected by the receiver which emits a tone that is correlated to the conductivity of the feature.

3. PROCEDURE

ECG personnel began with a utility survey utilizing active detection with the RD-7000+. This is done by directing hooking up to known surface features across the site such as lamp posts, electric / communication boxes, and valves. The surveyor then performed a passive scan with the RD-7000+ receiver to detect any energized utilities that may have not been located with the active scan. Any detected utilities were then marked in the field.

ECG personnel then walked across the survey area with the TW-6 in 3-5 foot spacing increments. The approximate size and shape of any conductive targets detected was then marked in white and will be further investigated with GPR.

GPR was then utilized to confirm the approximate depth of any utilities detected with the RD-7000+ and the size, shape, and depth of any anomalies located with the TW-6.

4. RESULTS

- Underground Utilities – All utilities were marked in APWA designated colors.
 - Electric (Red) - 1-3' bgs
 - Water (Blue) - 3-5' bgs
 - Storm Sewer (Green) - 2-3 bgs
 - Unknown (Pink) – 2-3 bgs

A site map is attached portraying all detected subsurface features.

5. SITE LIMITATIONS

- Ground Penetrating Radar – GPR depth of penetration was limited to 0-3 feet bgs. Conductive soils and fill material can limit the depth of signal penetration.
- The TW-6 cannot be utilized within close proximity to parked vehicles, reinforced concrete, or any other large metallic features.

6. DISCLAIMER

The limitations of a geophysical survey from both the site and equipment are important to consider when performing intrusive work at a survey site. The equipment is unable to maintain a constant depth of penetration or a constant level of effectiveness over the course of a survey due to subsurface and environmental conditions. The results provided both in this report and in the field should be used in conjunction with other methods including but not limited to, site plans, as-builts, sanborn maps, field observations, public-mark out services, soft-digging, pre-clearing, and historical documentation of the site. No survey or survey method can accurately show an exact

image of all subsurface conditions. The presence of non-detectable subsurface utilities and structures is always a risk at any site. Please take caution when proceeding with invasive work.

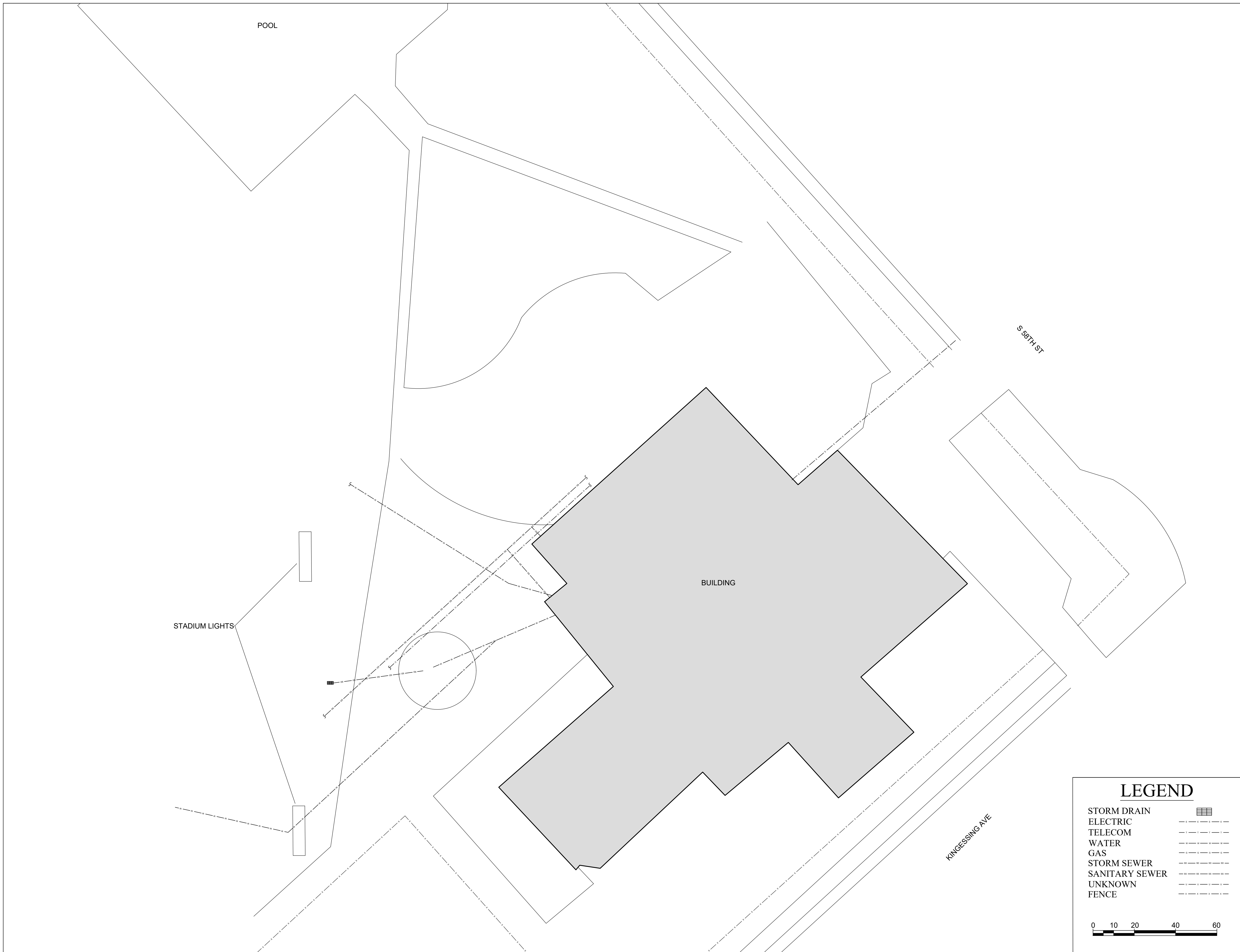

ADDRESS
 5801 KINGESSING AVE
 PHILADELPHIA PA

CLIENT
 GZA

DRAWING NO.

PROJECT NO.
 062722

SHEET NO.
 1 OF 1

DATE
 xx/xx/xxxx

SCALE
 1 OF 16

DRAWN
 T. DORATT

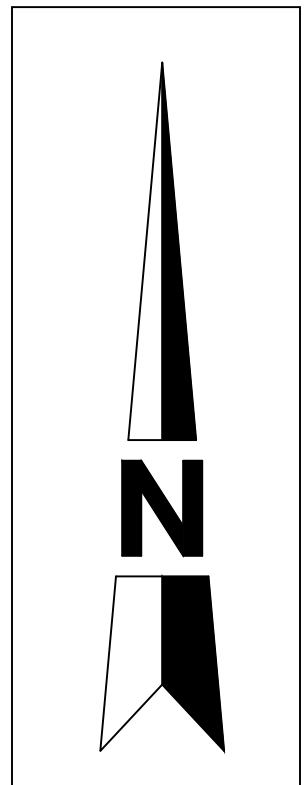

LEGEND

- STORM DRAIN
- ELECTRIC
- TELECOM
- WATER
- GAS
- STORM SEWER
- SANITARY SEWER
- UNKNOWN
- FENCE

REVISIONS		
NO.	INITIALS	DATE

NOTES:
 East Coast Geophysics, Inc. shall not be liable for damages of any kind arising out of the use of this information. Drawings are georeferenced based on satellite imagery and are not considered to be survey quality. These drawings are intended to be used as reference only.



GZA GeoEnvironmental, Inc.