

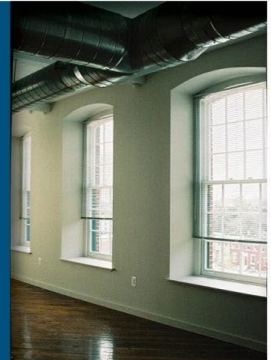

Philadelphia
Redevelopment
Authority



Request for Proposals (RFP)

Nelson Recreation Center Roof Replacement

301 W. Cumberland Street, Philadelphia, PA 19133

November 28, 2018

Table of Contents

Table of Contents	1
Application Process	2
Project Description/Scope of Work	3
Proposal Submission Requirements	4
Evaluation & Selection	4
Events of Disqualification or Default	5
Declarations and Other Information	5

Attachments:

- A. Division 0 (Bidding and Contract Requirements)
- B. Division 1 (General Requirements)
- C. Division 2 (Technical Specifications)
- D. Philadelphia Tax Status Certification and Conflict of Interest Form
- E. Campaign Contribution Disclosure Forms
- F. PRA Insurance Requirements
- G. Rebuild Project Statement
- H. City of Philadelphia Questionnaire & Financial Statement for Qualifying Bidders



Application Process

On behalf of the City of Philadelphia ("City"), the Philadelphia Redevelopment Authority ("PRA") is pleased to issue this Request for Proposals ("RFP") for qualified prime contractors (each, an "Applicant" and together, the "Applicants") for the Nelson Recreation Center roof replacement project located at 301 W. Cumberland Street, Philadelphia, PA 19133. This project is part of the City's Rebuilding Community Infrastructure Program ("Rebuild").

Submission Deadline

Applicants must submit a response/proposal (a "Response") no later than **January 4, 2019** at 3:00 PM; absolutely no Response will be accepted after that time.

Mandatory Pre-Bid Meeting

All Applicants must attend the mandatory pre-bid meeting at Nelson Recreation Center, 301 W. Cumberland Street, Philadelphia, PA 19133 at 10:00 A.M. on **December 12, 2018**.

The names and contact information for all attendees at the pre-bid meeting will be posted on PRA's website as public information within a few days of the pre-bid meeting.

Questions/Requests for Additional Information

PRA will accept questions and requests for additional information directed in writing to RFP@pra.phila.gov **up to 3 PM on December 17, 2018**. Questions, responses, and additional information will be posted on the PRA Website within **3 business days of December 17, 2018**.

Related Parties

Applicants may submit only one Response to this RFP. Individuals or businesses that are legally related to each other or to a common entity may not submit separate Responses. The PRA and City, in their sole and absolute discretion, retain the right to reject any Response where:

1. Applicants or principals of Applicants are substantially similar or substantially related parties; or;
2. The PRA and City have determined that the Applicant has violated these conditions or the spirit of these conditions.

Submission Process

Responses will only be accepted in either of the following:

1. Online Submission – via the electronic portal on PRA's website (<http://www.philadelphiaredevelopmentauthority.org/>); or
2. Hard Copy Submission – Submit 3 original copies of the Response and one electronic copy on a USB Flash Drive to the PRA via hand delivery or registered mail. Files on the USB Flash Drive may only be in Microsoft Word or Adobe PDF. Applicants may hand deliver or send their Response via registered mail to:



Robert LaBrum
Director, Design & Construction
Philadelphia Redevelopment Authority
1234 Market Street, 16th Floor
Philadelphia, PA 19107

Disqualification

Responses will be disqualified if:

1. They are submitted after the specified deadline;
2. They are submitted by some means other than the two formats listed above. For electronic Responses, the PRA website portal is the only means that will be accepted. Responses sent via email, Dropbox or other electronic venues will be disqualified;
3. If the Response package is incomplete.

Bid Price

The PRA will award this Project to the Response determined to be the most responsive based on the criteria explained below. Bid price is one of these criteria, though the Project will not necessarily be awarded to the lowest bidder. Bidders must complete and submit the Construction Bid Proposal Form located in Attachment A, Division 0 (Bidding and Contract Requirements).

Bid Bonds

Bidders must complete and submit the Bid Bond Form located in Attachment A, Division 0 (Bidding and Contract Requirements).

Schedule

The timeline for this opportunity is as follows:

Event	Date
RFP posted	November 28, 2018
Mandatory Pre-Bid Meeting	December 12, 2018
Questions and requests for additional information due	December 17, 2018; 3:00 PM
Responses due	January 4, 2019; 3:00 PM
Respondent selected (Estimate)	January 2019

PRA reserves the right, in its sole discretion, to alter this schedule as it deems necessary or appropriate.

Project Description/Scope of Work

The PRA is seeking Applicants for the Nelson Recreation Center roof replacement project located at 301 W. Cumberland Street. The work includes, but is not limited to, the removal of the existing roof system down to the wood deck and installation of tapered roof insulation and a new cold applied modified



bitumen roof system. The work also includes the installation of new metal fascia and coping. For completed scope of work please refer to the Project Drawings and the Specifications. This project is part of the City's Rebuilding Community Infrastructure Program ("Rebuild").

Response Submission Requirements

1. **Construction Bid Proposal Form** located in Attachment A, Division 0 (Bidding and Contract Requirements).
2. **Bid Bond** located in Attachment A, Division 0 (Bidding and Contract Requirements).
3. **Experience (Not to exceed two pages)**: Describe past experiences with providing similar projects. Please cite projects performed for the City of Philadelphia or other public/governmental agencies. Please include examples of projects that were completed on time and on budget.
4. **Approach to Project Delivery (Not to exceed one page)**: Describe your approach to carrying out the scope of work on time/budget, and strategies that make your firm qualified to best perform these services. Please include a detailed Project timeline.
5. **Economic Inclusion (Not to exceed one page)**. Provide a narrative describing Applicant's past performance in engaging certified Minority Business Enterprises ("MBE"), Woman Business Enterprises ("WBE"), and/or Disabled Business Enterprises ("DSBE") in subcontracting and in procuring goods and services; in addition, describe the Applicant's past performance in hiring local, diverse workforce, both in-house and with subcontractors. If Applicant is a Certified MBE, WBE or DBE; please submit information to confirm Certification as part of bid proposal. Please include contract and workforce participation goals and achievements on previous projects. Provide a plan for meeting contract and workforce participation goals (subcontractors, etc) for this Project.
6. **Declarations and Other Information**. Response must also include the completed forms identified in the Declarations and Other Information below.

Evaluation & Selection

PRA intends to award this Project to the Applicant that best demonstrates the level of experience, skill and competence required to perform the services called for in this RFP in the most efficient, cost-effective, and professional manner **and in a manner, that is consistent with the contract and workforce participation goals of the Rebuild initiative**. The PRA will initially review the Responses to determine compliance with the Response Submission Requirements. Only Responses that comply with these requirements will be considered for evaluation. If no Response meets these requirements, the PRA may allow all Applicants to supplement their Responses to conform to these requirements.

PRA will evaluate Applicants based on the following factors:

1. Complete application and eligibility of applicant including compliance with all requirements listed in this RFP;
2. Appropriateness of firm for the scope of work, and ability to carry out the work in a high-quality standard on time and budget;
3. Prior experience, including competence and proven track record working with City of Philadelphia and/or other public agencies;
4. Track record of economic inclusion in contracting and workforce;
5. Bid price;



6. Any other factors the PRA considers relevant to the evaluation of the responses; and
7. Financial capability

Events of Disqualification or Default

Subsequent to the selection of an Applicant, and before execution of the Contract, the PRA may treat any of the following as an event of disqualification or default:

1. Unilateral withdrawal by the selected Applicant;
2. Failure to proceed substantially in accordance with the Response as submitted;
3. Failure by the Applicant for any reason whatsoever to timely execute the Contract when tendered;
4. Material misrepresentation, omission, or inaccuracy contained in any document submitted either as part of the Response, or subsequent thereto. For the purposes of this section, the PRA places particular importance on the information required by the Applicant in the City of Philadelphia Questionnaire & Financial Statement for Qualifying Bidders and the Campaign Contribution Disclosure Forms;
5. Failure to provide in a timely manner the additional material required after selection throughout the PRA selection process.

Upon the happening of an event of disqualification or default by the selected Applicant, PRA shall have the right, at its election, to:

1. Rescind its selection; or
2. Declare null and void a Contract that may already have been executed.

Declarations and Other Information

Economic Opportunity Plan

This Project will require the selected Applicant to execute an Economic Opportunity Plan ("EOP"), committing to exhaust its best and good faith efforts to reach goals for diverse business inclusion and to employ an appropriate diverse workforce. The specific goals for this Project will be determined in consultation with the City's Office of Economic Opportunity. Adopted as part of City Council Resolution No. 180124 (2018), was a Rebuild Master Economic Opportunity Plan, which establishes certain goals for contracting and diverse employment for the Rebuild program. The Master EOP excerpt below is included in the Rebuild Project Statement, which is Attachment G of this RFP:



II. Rebuild Diversity and Inclusion Goals

A. Participation Goals for Diverse Business Inclusion

In order to achieve Diverse Business Inclusion in Rebuild, each contract between PAID and Project User will require an EOP containing participation ranges for M/W/DSBEs. Goals for Rebuild are informed by the City's most current Annual Disparity Study as follows:

Professional services contracts: 25-30% minority and 15-20% women

Construction contracts: 30-35% minority and 15-20% women

EOPs will contain individualized participation ranges for both MBEs and WBEs according to project scope and dollar value.

B. Employment Goals for Diverse Workforce

Project User agrees to exhaust its Best and Good Faith Efforts to employ an appropriately diverse workforce which will include minority persons and females at all tiers of employment and management. Project User shall also cause its Participants to employ an appropriately diverse workforce. For this Plan, an appropriately diverse workforce is one which reflects the local availability and historic utilization of Philadelphia residents, and also recognizes underutilization of diverse workers across all trades. The following are expressed as hourly project goals:

Total minority journey person hours 45% (African American journey persons 27%, Hispanic journey persons 15%, and Asian journey persons 3%); and of the foregoing total minority workforce hours, 60% laborer hours and 40% skilled hours.

Total women journey person hours 5%, skilled and laborer.

Total minority apprentice workforce hours 50%, skilled and laborer and total women apprentice workforce hours 5%, skilled and laborer.

Local construction workforce: 50-60%.

Tax Clearance and Conflict of Interest Form

Applicants, upon request of the PRA, must provide evidence satisfactory to the PRA that all municipal taxes, including business taxes, real estate, school, water and sewer charges, if applicable, are current for both the individual Applicant and the Applicant's firm, and that neither is currently indebted to the City; will at any time during the term of the contract be indebted to the City, for or on account of any delinquent taxes, liens, judgments, fees or other debts for which no written agreement or payment plan satisfactory to the City has been established. Please complete the Philadelphia Tax Status Certification and Conflict of Interest form (Attachment D) and submit it with your Response.

Compliant with City of Philadelphia Revenue Department

Bidders must have a current City of Philadelphia Business Activity License and have a valid contractor's license.



Campaign Contribution Disclosure Forms

Please complete the applicable disclosure forms (Attachment E) and submit with your proposal.

City of Philadelphia Questionnaire & Financial Statement for Qualifying Bidders

Please complete the applicable questionnaire and financial statements (Attachment H) and submit with your proposal.

Insurance Requirements

Please submit a certificate of insurance evidencing the required coverages as outlined in Attachment F with your Response. If, for any reason, you cannot comply with the insurance requirements, please provide the reasons for your inability to do so and the PRA will consider any deviations from the insurance requirements on a case-by-case basis.

By submitting a Response to this RFP, an Applicant affirmatively acknowledges: (i) its acceptance of the terms and conditions of this RFP; (ii) the PRA may exercise in its sole discretion the following rights; and (iii) the PRA may exercise the following rights at any time and without notice to any Applicant:

1. to reject any and all Responses;
2. to supplement, amend, substitute, modify or re-issue the RFP with terms and conditions materially different from those set forth here;
3. to cancel this RFP with or without issuing another RFP;
4. to extend the time period for responding to this RFP;
5. to solicit new Responses;
6. to conduct personal interviews with any Applicant to assess compliance with the selection criteria;
7. to request additional material, clarification, confirmation or modification of any information in any and all Responses;
8. to negotiate any aspect of a Response, including price;
9. to terminate negotiations regarding any and all Responses at any time;
10. to expressly waive any defect or technicality in any Response;
11. to rescind a selection prior to Contract execution if the PRA determines that the Response does not conform to the specifications of this RFP;
12. to rescind a selection prior to Contract execution if the PRA determines that the specifications contained in this RFP are not in conformity with law or that the process in selection of an Applicant or Response was not in conformity with law or with the legal obligations of the PRA;
13. in the event a Contract is awarded, the successful Applicant or Applicants shall procure and maintain during the life of the Contract liability insurance in an amount to be determined prior to the award of the Contract;
14. in the event a Contract is awarded, all Applicants agree to perform their services as an independent contractor and not as an employee or agent of the PRA;
15. in the event a Contract is awarded, all Applicants agree that no portion of performance of the contract shall be subcontracted without the prior written approval of the PRA; and
16. each Applicant agrees to indemnify, protect and hold harmless the PRA from any and all losses, injuries, expenses, demands and claims against the PRA or the City sustained or alleged to have been sustained in connection with or resulting from (i) the submission of the Applicant's Response; (ii) the delivery by the Applicant to the PRA of any other documents or information; and (iii) any other conduct undertaken by the Applicant in furtherance of or in relation to the Applicant's proposal. Each Applicant agrees that its duty to indemnify and hold



harmless shall not be limited to the terms of any liability insurance, if any, required under this RFP or subsequent contract.

The PRA is under no obligation whatsoever to Applicant as a result of this RFP. The RFP does not represent any commitment on the part of the PRA to Applicant or the Project. In no event shall the PRA be responsible for any cost, expense or fee incurred by or on behalf of Applicant in connection with the RFP. Applicant shall be solely responsible for all such costs, expenses and fees.

NOTICE: The PRA is subject to the Pennsylvania Right to Know Law. Any information provided in your Response to this may be subject to disclosure to the public. Documents provided in response to this RFP may also be required to be disclosed by applicable law, subpoena, and/or court order.



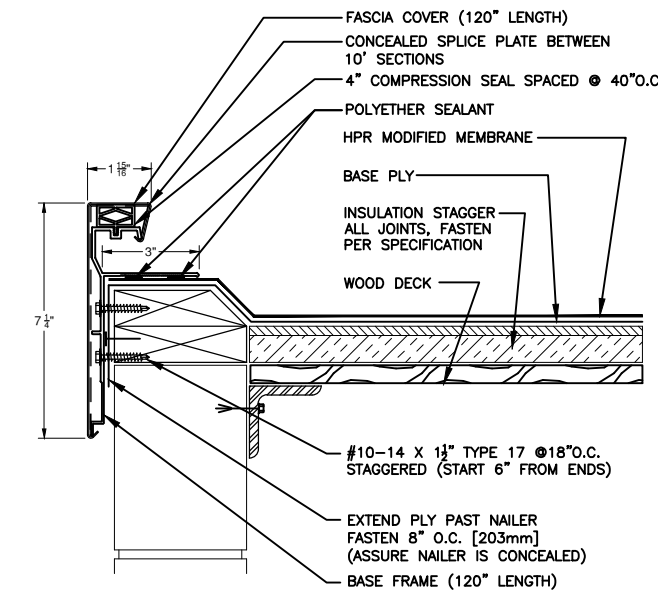

SK-9 RAISED METAL EDGE FLASH-LESS FASCIA

1 SCALE: NTS

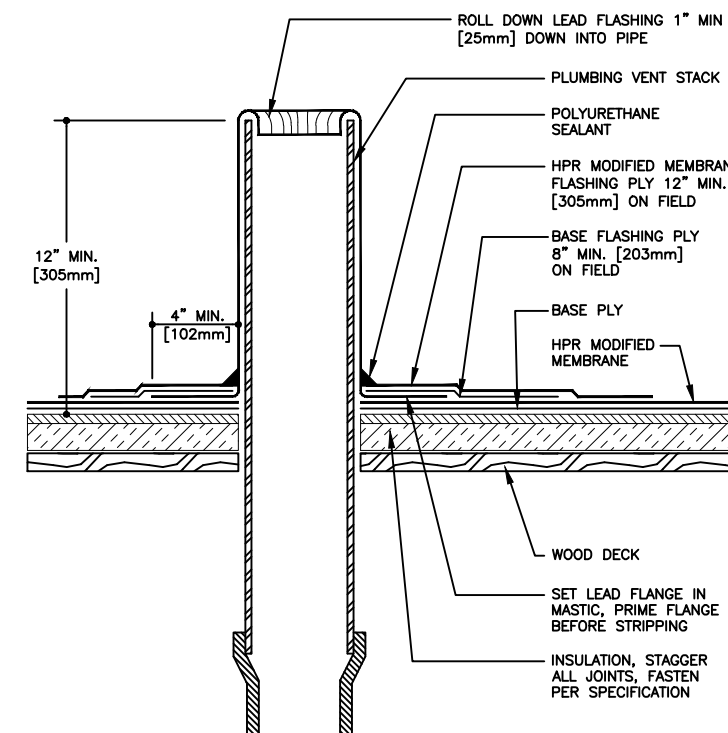

SK-8 PLUMBING STACK

1 SCALE: NTS

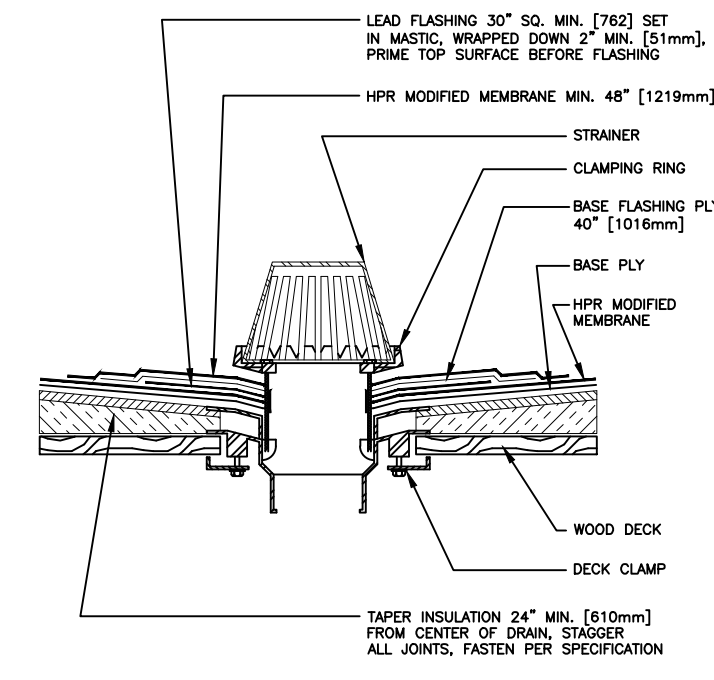

SK-7 ROOF DRAIN

1 SCALE: NTS

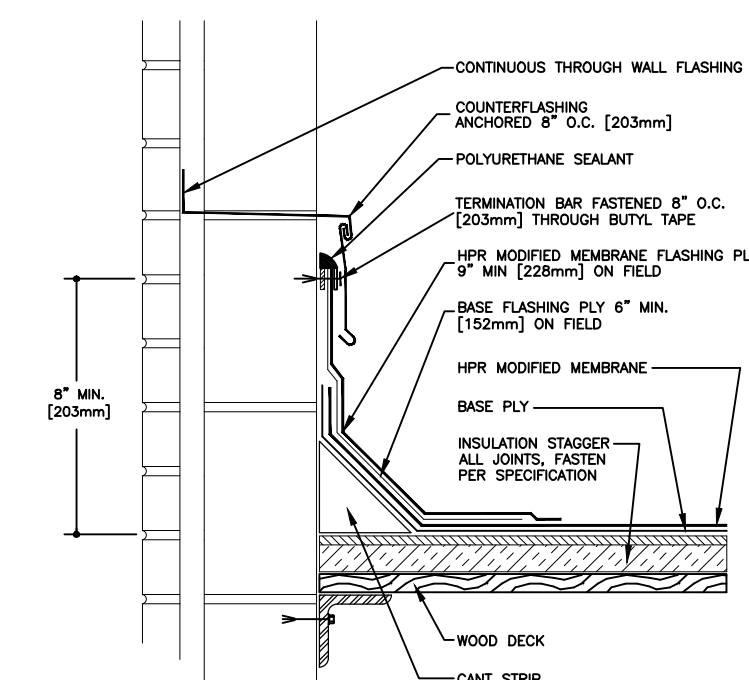

SK-6 THROUGH WALL COUNTERFLASHING

1 SCALE: NTS

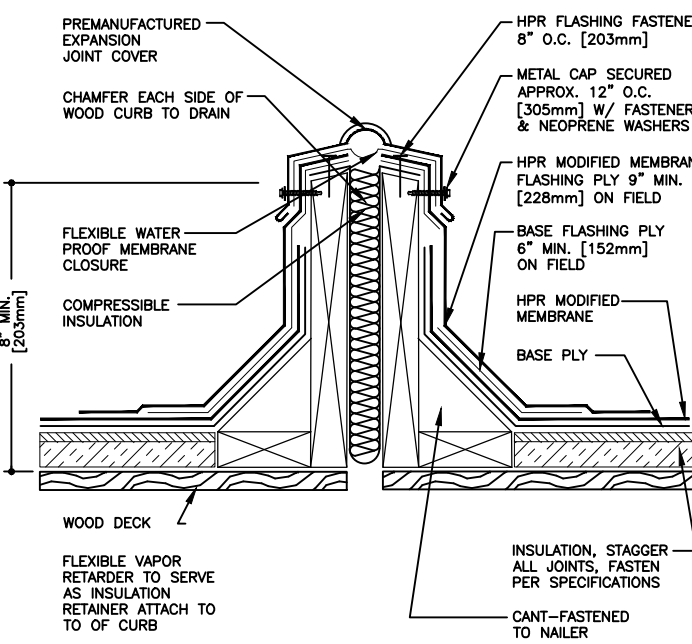

SK-5 EXPANSION JOINT

1 SCALE: NTS

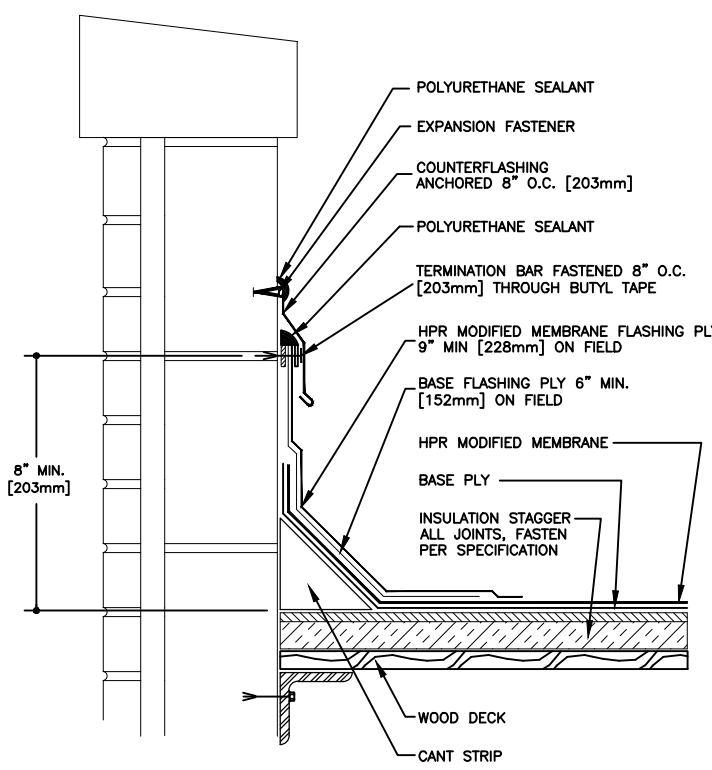

SK-4 REGLET MTD. COUNTERFLASHING

1 SCALE: NTS

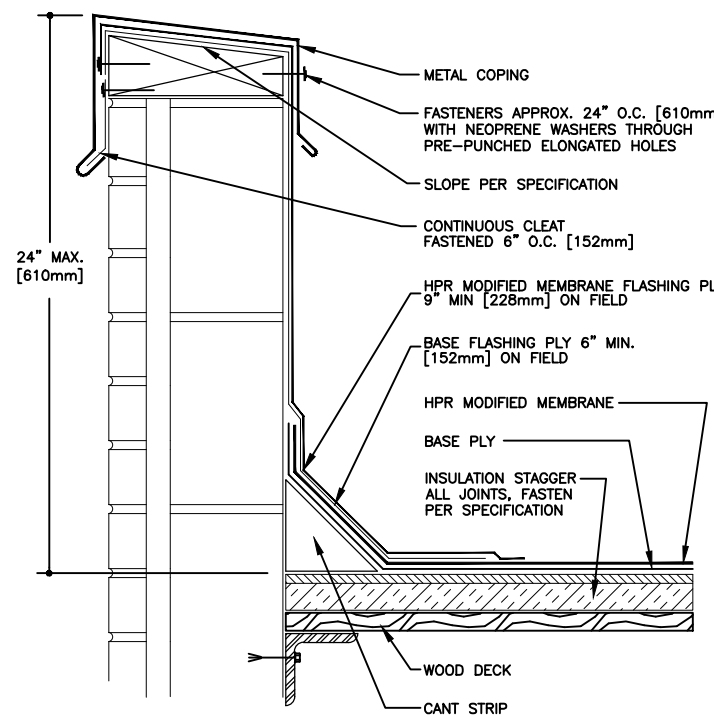

SK-3 COPING CAP

1 SCALE: NTS

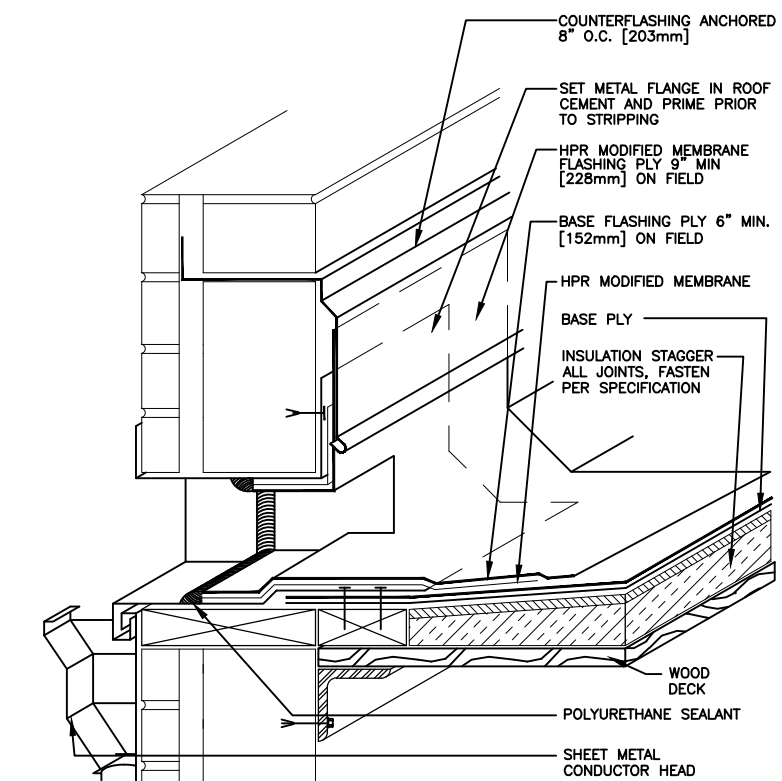

SK-2 THROUGH WALL SCUPPER

1 SCALE: NTS

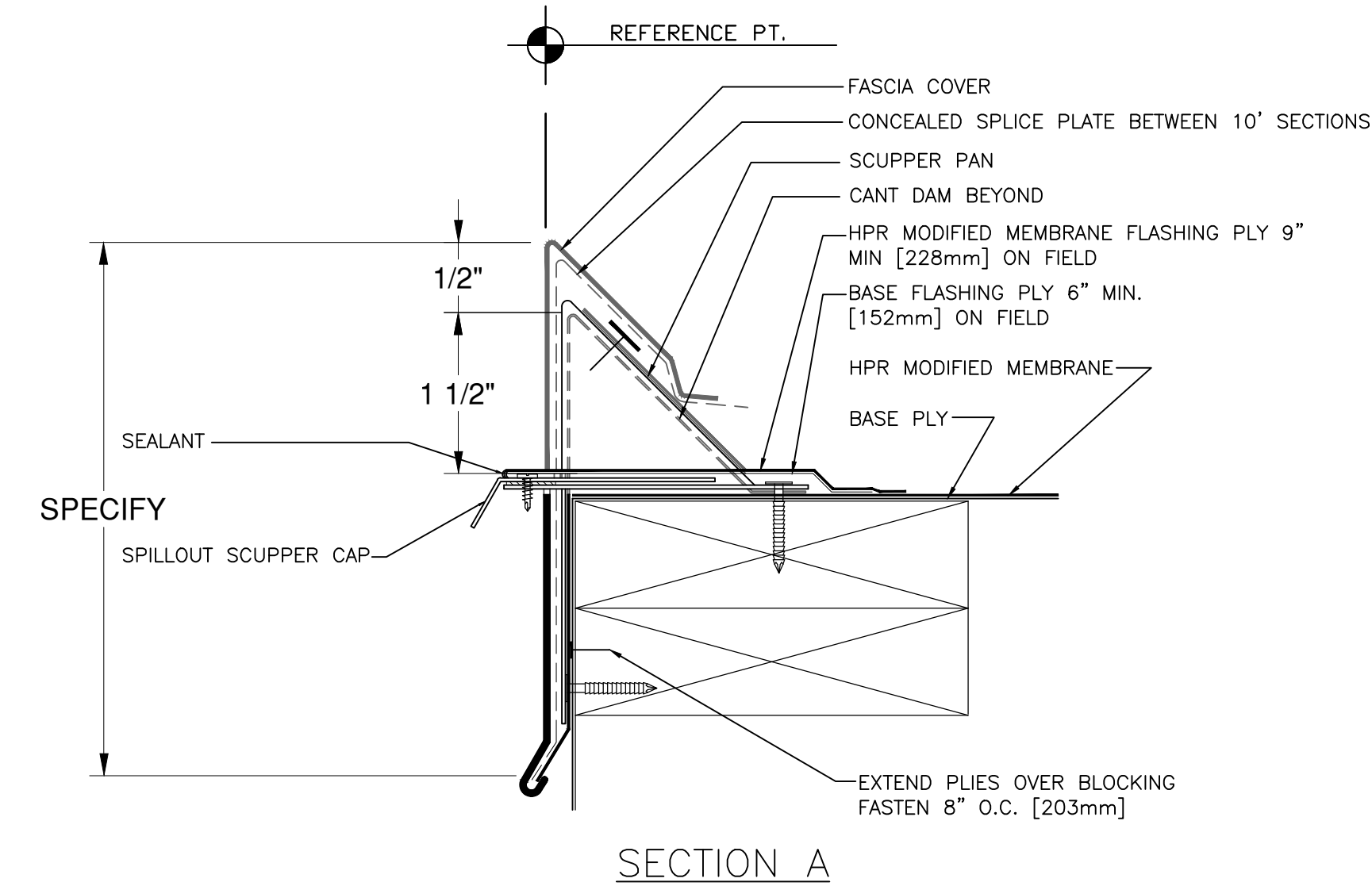
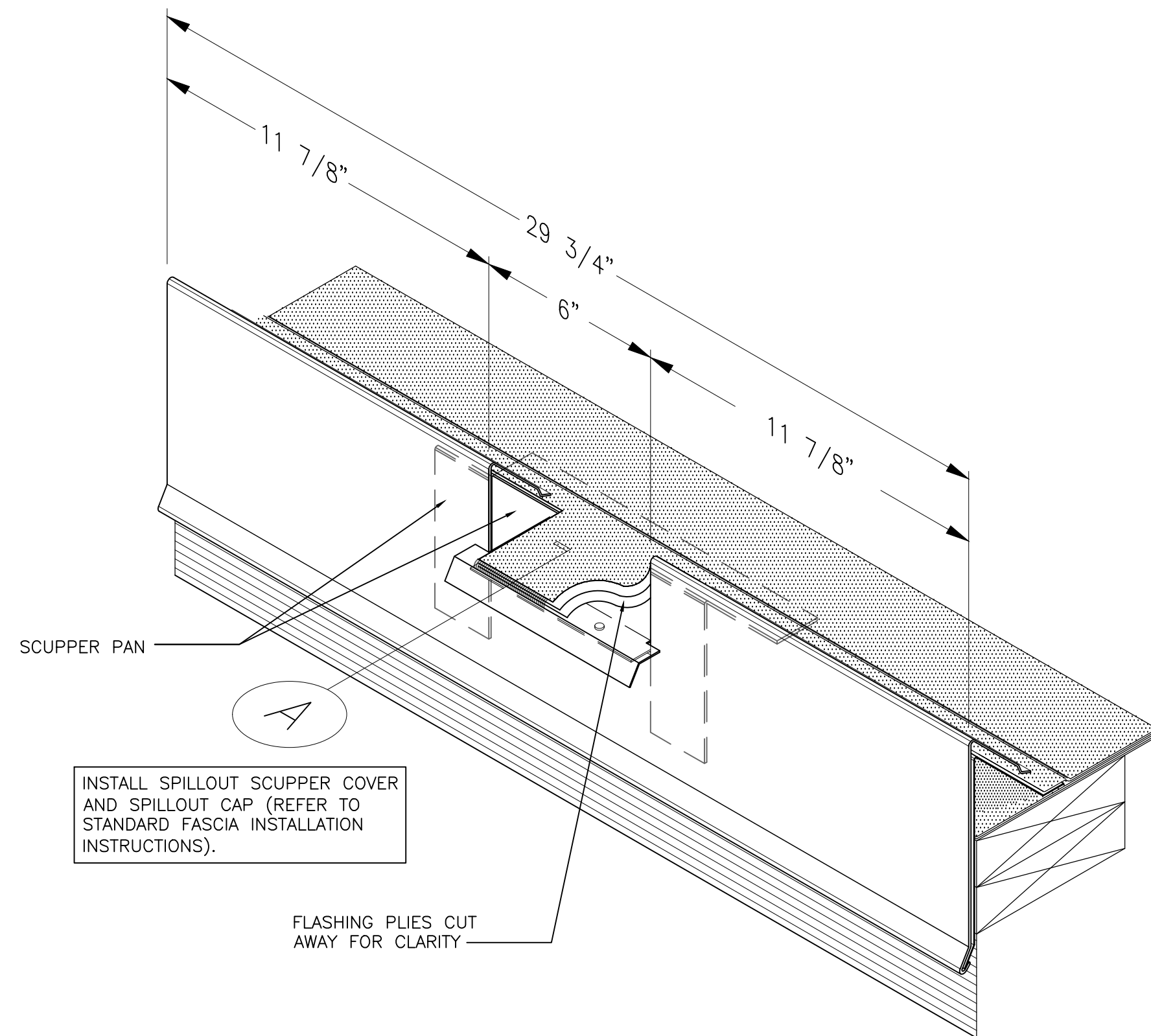

SK-1 ES-FX CONCEALED SCUPPER DETAIL

1 SCALE: NTS

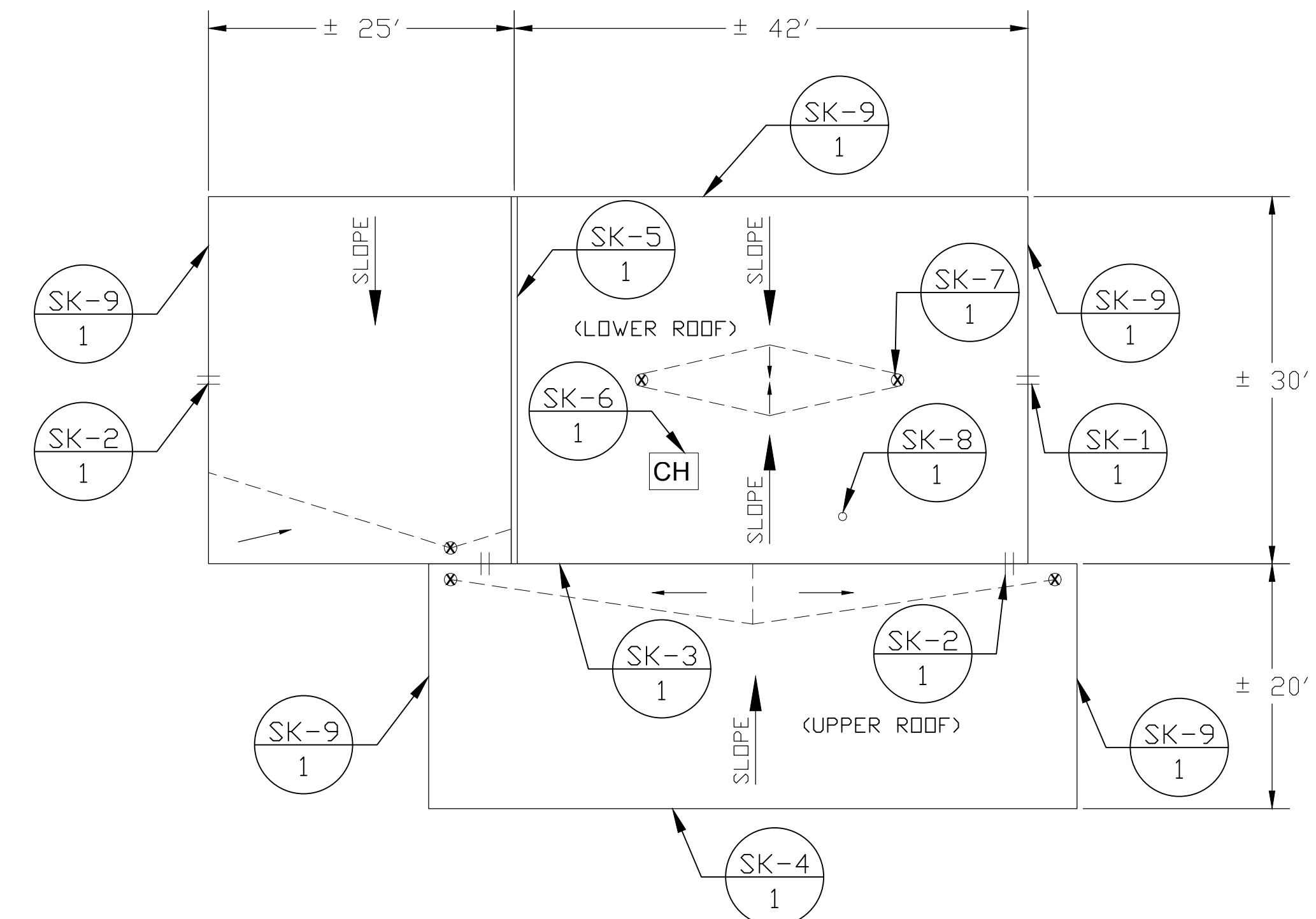

ROOF PLAN

SCALE: N.T.S.

NELSON RECREATION CENTER ROOF REPLACEMENT RFP

PRE-CONSTRUCTION MEETING - WEDNESDAY, DECEMBER 12, 2018

<u>Name:</u>	<u>Company:</u>	<u>Phone Number:</u>	<u>Email/Website:</u>
Ben Pavone	BFW Group	215-798-1055	www.bfwgroup.net
Sean Plower	United States Roofing Corporation	610-272-6600	www.usroofing.com
Tyler Rooney	Robert Ganter Contractors, Inc.	856-848-3060	jgannon@gantercontractors.com
Ian Gregory	Munn Roofing Corp.	215-997-2258	www.munnroofingcorp.com
Titus Detwiler	Detwiler Roofing	717-200-9000	www.detwilerroofing.com
Pat Tarsi	Garland Company	610-715-1700	ptarsi@garlandind.com

Nelson Recreation Center Roof Replacement RFP:

Addendum No. 1:

Date: December 17, 2018

Additional Scope:

1. Furnish and install new metal fascia extenders to cover the existing barge board. The new metal fascia extenders shall be fabricated using .040 aluminum.
2. The existing metal box in the NW corner of the upper roof will be flashed according to the roofing material manufacturer's specifications.
3. Chimney Repairs:
The four (4) sides of the chimney will be covered with .040 aluminum cladding. The chimney cap will be fabricated from .040 aluminum.

Questions:

1. Is this a Prevailing Wage Project?
ANSWER: Yes
2. What is the Square Footage of the Project?
ANSWER: Approximately 3,000 Square Feet

Clarifications:

1. Please see revised and attached Roofing Construction Proposal (Attachment A – Division 00411 of the RFP below). Please use the revised form with your proposal.

Please note – the Proposals are due no later than **January 4, 2019 at 3:00 PM.**

Acknowledgement: _____

SECTION 00411
ROOFING CONSTRUCTION PROPOSAL

PHILADELPHIA REDEVELOPMENT AUTHORITY
NELSON RECREATION CENTER ROOF REPLACEMENT

301 W. CUMBERLAND STREET
PHILADELPHIA, PA 19133

THIS BID FORM IS COMPLETE AND MUST NOT BE SEPARATED. IF ANY SHEET OR SHEETS ARE DETACHED WHEN SUBMITTED AS A BID, THE PROCUREMENT COMMISSIONER RESERVES THE RIGHT TO REJECT YOUR BID.

FIRM NAME

FIRM ADDRESS

FEDERAL EIN

TOTAL BASE BID

PHILADELPHIA BUSINESS TAX ID

To the Philadelphia Redevelopment Authority:

I, the undersigned Bidder, hereby propose to furnish all the labor, materials and equipment, perform the whole of the work, and submit to all conditions, as represented, intended and implied, both particularly and generally, by the Plans, Special Specifications, Standard Specifications, Standard Details, Standard Contract Requirements, Form of Agreement, the Ordinance authorizing the work and this bid at the prices herein stated, and agrees that each item bid shall be complete in itself, and the Philadelphia Redevelopment Authority may increase or diminish the amount of work thereunder, or omit the item without invalidating the unit price bid for it or any other item, on the following terms to wit:

A. BID AMOUNT

I will complete the Work in accordance with the Contract Documents for the following Bid Amount as defined in Section 00700, Standard Contract Requirements. (Insert Bid Amount in words as well as figures.)

(1) BASE BID AMOUNT _____
_____ DOLLARS, \$ _____

(2) ALLOWANCE No. 1 Bidders are to include the amount equal to Two Percent (2%) of their base bid amount for payment of Permit and License fees to all regulatory agencies. Refer to Allowances, Section 01210 for more details. ALLOWANCE AMOUNT
_____ DOLLARS, \$ _____

TOTAL BASE BID (Base Bid plus Allowance(s)).
_____ DOLLARS, \$ _____

B. PERFORMANCE OF THE WORK BY CONTRACTOR:

I, the undersigned Contracting Bidder, am required to perform work on the site with its own workforce equal to at least twenty percent (20%) of the original total contract price exclusive of profit, overhead and the costs of procuring insurance and bonds. I, the undersigned Contracting Bidder, shall submit with its bid a complete description of the work that will be performed (e.g., earthwork, paving, brickwork, roofing, etc.), the percentage of the total contract this work represents, and the estimated dollar value thereof.

I shall perform the following work: _____

Percentage of the total contract to be performed by Contracting Bidder:

Estimated cost of work to be performed by Contracting Bidder: \$ _____

C. COMPLETION

I will substantially complete the Work, ready for final payment, in accordance with the Contract Documents within 150 consecutive calendar days counting from the date stated in the Notice to Proceed.

D. ADDENDA

Bidder must attach Addendum Acknowledgement sheets for all Addenda, if applicable.

Addendum #1, dated: December 17, 2018

EXECUTION OF CONTRACT

This contract consists of the Standard Contract Requirements; the Department’s Standard Details and Specifications, as they apply; the Department’s General Bidding and Contract Requirements; the Technical Specifications; the Bid; the Plans with all of the notes thereon (excluding any records or reports of test borings, underground structures, and test piles); any additional exhibits or attachments to any of the foregoing; and any addenda thereto issued by the City (collectively, the “Contract”).

NOTE: ANY CONTRACT THAT IS NOT EXECUTED IN ACCORDANCE WITH THE INSTRUCTIONS PROVIDED BELOW, MAY, IN THE SOLE DISCRETION OF THE PHILADELPHIA REDEVELOPMENT AUTHORITY, BE REJECTED.

SIGNING OF CONTRACT

If Contractor is an INDIVIDUAL or a PARTNERSHIP, date and sign the Contract here, with original signatures, in ink.

This _____ day of _____ 2018

(Signature of Owner, Partner)

(Type or Print Name and Title)

(Business Name of Bidder)

If Contractor is a CORPORATION, date and sign the Contract here with original signatures, in ink, by (a) President or Vice-President of the corporation AND (b) Secretary, Assistant Secretary, Treasurer or Assistant Treasurer of the corporation; and (c) affix the seal of the corporation. If the Contract is not signed by the President or Vice-President; and Secretary, Assistant Secretary; Treasurer or Assistant Treasurer, attach a duly certified corporate resolution authorizing the person signing in place of such officers to execute this Contract for the corporation.

This _____ day of _____ 2018

CORPORATE SEAL

(Corporate or Business Name of Bidder)

(Address, Including Zip Code)

(Telephone Number)

(Signature of President or Vice President)

(Signature of Secretary, Asst. Secretary, Treasurer or Assistant Treasurer)

(Type or Print Name and Title)

(Type or Print Name and Title)